

# B200SLF Status Beacon [Filament Lamp]

The B200 series is comprised of a Xenon strobe beacon, permanent filament bulb, blinking filament bulb and a permanent LED array beacon version.

The surface mount base can also be supplied with a right angle bracket or with a pole mounted assembly.

## Features

- Bayonet fixing lens.
- Anti-tamper locking screw.
- Stainless steel fixings.

## Approvals

- GOST-R certificate: POCC GB.JB05.H00144.



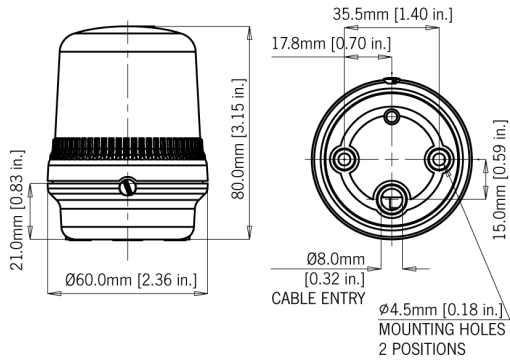

### Specification

Light source:	Filament lamp BA9s
Light output:	5W
Function:	Permanent
Candela:	5 cd* (peak/effective intensity)
Lens colours:	Amber, Blue, Clear, Green, Red & Yellow
Lens type:	Prismatic (standard) or plain
Mounting:	Surface mount (right angle or pole mount accessories available)
Ingress protection:	IP65
Housing material:	High impact UL94 V0 (f1) PC
Lens material:	High impact UL94 V0 (f1) PC
Terminals:	0.5 to 1.5mm <sup>2</sup>
Operating temp:	-25 to +50°C [-13° to +122°F]
Storage temp:	-40 to +70°C [-40° to +158°F]
Relative humidity:	90% at 20°C [68°F]
Weight:	78g/1.71lbs

\*Candela measurements representative of performance with clear lens at optimum voltage.

### Part Codes

Version:	Wattage:	Part code:
12-250V	5W	B2.00SLF2.50B/[x]
[x] = Lens colour:		A: Amber
		B: Blue
		C: Clear
		G: Green
		R: Red
		Y: Yellow

NOTE: Filament lamps not included.

**AUTHORIZED DISTRIBUTOR:**  
**GasDetectorsUSA.com**  
**Houston, Texas USA**  
**sales@GasDetectorsUSA.com**  
**832-615-3588**