

# D2xC1X10 Alarm Horn Sounder & Xenon Strobe 10J

The D2xC1X10 features a high output, 116dB(A) alarm horn sounder combined with a 10 Joule Xenon strobe beacon. Globally approved, the robust Type 4/4X, IP66 enclosure ensures suitability for all haz loc fire alarm and general signalling applications.

The corrosion proof, marine grade aluminium die cast enclosure is chromated and powder coated providing resilience in the harshest of hazardous location environments. One device, globally certified: ATEX, IECEx Zone 2 & 22; NEC/CEC CI D2 and CII D2; NEC CI Zone 2 and Zone 22; CEC Zone 2 & 22 and CII D2. UL & cUL approved 24Vdc version for fire alarm use.

## Features

- 10 Joule Xenon beacon with 116dB(A) alarm horn
- Effective Intensity: 288.8 cd
- Peak Candela: 101,784 cd
- 64 alarm tones, 4 remotely selectable alarm stages/channels
- Automatic synchronisation on multi-sounder system
- Field replaceable lens colour filters

## Approvals

- UL File ref: E230764
- IECEx cert: IECEx ULD 14.0004X
- ATEX cert: DEMKO 14 ATEX 4786493904X
- CSFM listing: 7136-2279:0503



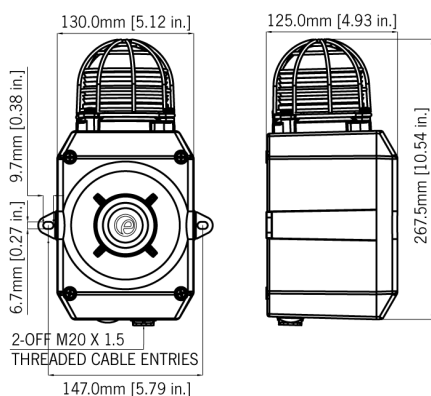

## Specification

### Alarm Horn

#### Sounder:

Maximum output:	116dB(A) @ 1 metre [107dB(A) @ 10ft/3m]
Nominal output:	112dB(A) @ 1m +/- 3dB - Tone 2 [103dB(A) @ 10ft/3m]
No. of tones:	64 (UK00A / PFEER compliant)
No. of stages:	4
Volume control:	Adjustable -12dB(A) [Tone 2]
Effective range:	125m/410ft @ 1KHz
Stage switching:	DC units - Positive or Negative line. AC units - common supply line

### Xenon Strobe

#### Beacon:

Energy:	10 Joules (10Ws)
Flash rate:	1Hz (60 fpm)
Peak Candela:	1,000,000 cd - calculated from energy (J)
Effective Intensity:	500 cd - calculated from energy (J)
Peak Candela:	101,784 cd - measured ref. to I.E.S.
Effective Intensity cd:	288.8 cd - measured ref. to I.E.S.
Lens colours:	Amber, Blue, Clear, Green, Magenta, Red & Yellow
Tube life:	Emissions are reduced to 70% after 8 million flashes

#### General:

Voltages DC:	24V dc [20-28Vdc]
Voltages AC:	115V ac 50/60Hz; 230V ac 50/60Hz
Ingress protection:	EN60529: IP66 UL50E / NEMA250: 4 / 4X / 3R / 13
Housing material:	Marine grade aluminium Al Si12 Cu
Colour:	Red (RAL3000), grey (RAL7038)
Cable entries:	2 x M20 x 1.5mm threaded gland entries
Terminals:	0.5 - 2.5mm <sup>2</sup> (20-14 AWG)
Grounding stud:	M5
Operating temp:	-40 to +70°C [-40° to +158°F] - Class I Div 2 -40 to +50°C [-40° to +122°F] - All other approvals
Relative humidity:	95%
Weight:	DC: 2.80kg/6.16lbs AC:3.10kg/6.82lbs

## Part Codes

Version:	Part code:	Description:
Product type:	D2xC1X10	Haz Loc alarm horn sounder & Xenon strobe beacon
Voltage:	DC024	24V dc - UL/cUL Fire Alarm
	DC048	48V dc
	AC115	115V ac
	AC230	230V ac
Cable Entry Type: [e]	A	2 x M20x1.5mm
	B	2 x 1/2" NPT - adaptors
	C	2 x 3/4" NPT - adaptors
	D	2 x M25x1.5mm - adaptors
	E	1 x 1/2" NPT - adaptor
	F	1 x 3/4" NPT - adaptor
	G	1 x M25x1.5mm - adaptor
Adaptor/Stopping plug material: [m]	B	Brass
	N	Nickel Plated
	S	Stainless Steel
Lens guard matl. & tag: [s]	1	A2 304 Stainless Steel
	2	A4 316 Stainless Steel
	3	A2 304 St/St with Equip. Tag
	4	A4 316 St/St with Equip. Tag
Product version: [v]	A1	UL, cUL, IECEx & ATEX
Enclosure colour: [x]	R	Red RAL3000
	G	Grey RAL7038
Lens colour: [y]	A	Amber
	B	Blue
	C	Clear
	G	Green
	M	Magenta
	R	Red
	Y	Yellow
Accessories:	SP65-0001-A2	Pole Mount Bracket Kit 2" St/St A2 (304)
	SP65-0001-A4	Pole Mount Bracket Kit 2" St/St A4 (316)
	SP65-0002-A2	Sunshade - St/St A2 (304)
	SP65-0002-A4	Sunshade - St/St A4 (316)

## Alarm Sounder

Version:	Voltage:	Current:
24V dc	10-30V dc	313mA [at nominal voltage]
115V ac 50/60Hz	+/-10%	90mA
230V ac 50/60Hz	+/-10%	52mA

## Xenon Beacon

Version:	Voltage:	Current:
24V dc	20-28V dc	823mA [at nominal voltage]
115V ac 50/60Hz	+/-10%	211mA

### Tone table

S 1	Description	S 2	S 3	S 4	S 1	Description	S 2	S 3	S 4
T 2	1200/500 @ 1Hz Sweeping - DIN / PFEER P.T.A.P.	T 1	T 3	T 44	T 34	800 @ 2Hz (0.25s on, 0.25s off) - IMO code 3...	T 56	T 24	T 8
T 3	1000 @ 0.5Hz (1s on, 1s off) Intermittent - P...	T 1	T 2	T 44	T 35	1000 @ 1Hz (0.50s on, 0.50s off) Intermittent	T 44	T 24	T 8
T 4	1.4KH-1.6KHz 1s, 1.6KHz-1.4KHz 0.5s - NF C 48...	T 44	T 24	T 1	T 36	2400 @ 1Hz (0.50s on, 0.50s off) Intermittent	T 21	T 24	T 8
T 5	544(100mS)/440 (400mS) - NF S 32-001	T 52	T 19	T 1	T 37	2900 @ 5Hz (0.10s on, 0.10s off) Intermittent	T 53	T 24	T 8
T 6	1500/500 - (0.5s on , 0.5s off) x3 + 1s gap -...	T 7	T 44	T 1	T 38	363/518 @ 1Hz (0.50s / 0.50s) Alternating	T 1	T 8	T 19
T 7	500-1500Hz Sweeping 2 sec on 1 sec off - AS4428	T 6	T 44	T 1	T 39	450/500 @ 2Hz (0.25s / 0.25s) Alternating	T 1	T 8	T 19
T 8	500/1200Hz @ 0.26Hz(3.3s on, 0.5s off) - NEN ...	T 44	T 24	T 35	T 40	554/440 @ 1Hz (0.50s / 0.50s) Alternating	T 44	T 24	T 19
T 9	1000 (1s on, 1s off)x7 + (7s on, 1s off) - IM...	T 18	T 34	T 1	T 41	554/440 @ 0.65Hz (0.76s / 0.76s) Alternating	T 1	T 8	T 19
T 10	1000 (1s on, 1s off)x7 + (7s on, 1s off) - IM...	T 21	T 34	T 1	T 42	561/760 @ 0.83Hz (0.60s / 0.60s) Alternating	T 1	T 8	T 19
T 11	420(0.5s on, 0.5s off)x3 + 1s gap - ISO 8201 ...	T 44	T 1	T 8	T 43	780/600 @ 0.96Hz (0.52s / 0.52s) Alternating	T 1	T 8	T 19
T 12	1000(0.5s on, 0.5s off)x3 + 1s gap - ISO 8201...	T 44	T 1	T 8	T 44	800/1000 @ 2Hz (0.25s / 0.25s) Alternating	T 5	T 24	T 19
T 13	422/775 - (0.85 on, 0.5 off) x3 + 1s gap - ...	T 44	T 1	T 8	T 45	970/800 @ 2Hz (0.25s / 0.25s) Alternating	T 1	T 8	T 19
T 14	1000/2000 @ 1Hz - Singapore	T 23	T 3	T 35	T 46	800/1000 @ 0.875Hz (0.57s / 0.57s) Alternating	T 53	T 24	T 19
T 15	300 Continuous	T 44	T 24	T 35	T 47	2400/2900 @ 2Hz (0.25s / 0.25s) Alternating	T 57	T 24	T 19
T 16	440 Continuous	T 44	T 24	T 35	T 48	500/1200 @ 0.3Hz (1.67s / 1.67s) Sweeping	T 44	T 24	T 12
T 17	470 Continuous	T 44	T 24	T 35	T 49	560/1055 @ 0.18Hz (2.73s / 2.73s) Sweeping	T 44	T 24	T 12
T 18	500 Continuous - IMO code 2 (Low)	T 44	T 24	T 35	T 50	560/1055 @ 3.3Hz (0.15s / 0.15s) Sweeping	T 44	T 24	T 12
T 19	554 Continuous	T 64	T 24	T 35	T 51	600/1250 @ 0.125Hz (4s / 4s) Sweeping	T 44	T 24	T 12
T 20	660 Continuous	T 44	T 24	T 35	T 52	660/1200 @ 1Hz (0.50s / 0.50s) Sweeping	T 64	T 24	T 12
T 21	800 Continuous - IMO code 2 (High)	T 44	T 24	T 35	T 53	800/1000 @ 1Hz (0.50s / 0.50s) Sweeping	T 56	T 24	T 12
T 22	1200 Continuous	T 44	T 24	T 35	T 54	800/1000 @ 7Hz (0.07s / 0.07s) Sweeping	T 57	T 24	T 12
T 23	2000 Continuous	T 15	T 3	T 35	T 55	800/1000 @ 50Hz (0.01s / 0.01s) Sweeping	T 54	T 24	T 12
T 24	2400 Continuous	T 48	T 20	T 35	T 56	2400/2900 @ 7Hz (0.07s / 0.07s) Sweeping	T 57	T 24	T 12
T 25	440 @ 0.83Hz (0.60s on, 0.60s off) Intermittent	T 1	T 44	T 8	T 57	2400/2900 @ 1Hz (0.50s / 0.50s) Sweeping	T 47	T 24	T 12
T 26	470 @ 0.9Hz (0.55s on, 0.55s off) Intermittent	T 1	T 44	T 8	T 58	2400/2900 @ 50Hz (0.01s / 0.01s) Sweeping	T 54	T 24	T 12
T 27	470 @ 5Hz (0.10s on, 0.10s off) Intermittent	T 1	T 44	T 8	T 59	2500/3000 @ 2Hz (0.25s / 0.25s) Sweeping	T 44	T 24	T 12
T 28	544 @ 1.14Hz (0.43s on, 0.44s off) Intermittent	T 44	T 24	T 8	T 60	2500/3000 @ 7.7Hz (0.65s / 0.65s) Sweeping	T 44	T 24	T 12
T 29	655 @ 0.875Hz (0.57s on, 0.57s off) Intermittent	T 1	T 44	T 8	T 61	800Hz Motor Siren	T 44	T 24	T 12
T 30	660 @ 0.28Hz (1.80s on, 1.80s off) Intermittent	T 44	T 24	T 8	T 62	1200Hz Motor Siren	T 44	T 24	T 12
T 31	660 @ 3.3Hz (0.15s on, 0.15s off) Intermittent	T 30	T 24	T 8	T 63	2400Hz Motor Siren	T 44	T 24	T 12
T 32	745 @ 1Hz (0.50s on, 0.50s off) Intermittent	T 44	T 24	T 8	T 64	Simulated Bell	T 44	T 21	T 12
T 33	800 (0.25s on, 1.00s off) Intermittent	T 53	T 24	T 8					