

H100BL Signal Horn & LED Beacon

Rated for continuous use the H100 series is a compact, high output signal suitable for a variety of installations. In addition to the 'buzzer' type sound the unit features a further two alarm sounds.

The H100BL incorporates the H100B with a high output permanent LED array. It is available in five L.E.D colours and operating voltages from 10V dc to 230V ac.

Features

- Volume control.
- Stainless steel fixings.
- Bayonet fixing lens.
- Anti-tamper locking screw.

Approvals

- GOST-R approved: POCC GB-JB05-H00144.



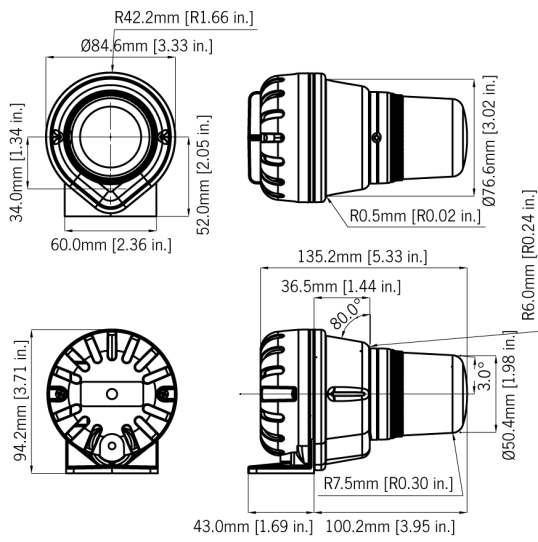

Specification

Horn:

No. of tones:	3
Output:	100 dB(A) @ 1m

Beacon:

Light source:	9 x High power L.E.D.'s
Function:	Permanent
Peak/Effective Intensity cd:	5.5 cd* - measured ref. to I.E.S.
Lens colours:	Amber, Blue, Clear (White L.E.D), Green, Red & Yellow
Lens type:	Prismatic (standard) or plain

General:

Dimensions:	135.2 x 94.2mm
Mounting:	Surface mount
Entries:	1 x 5-7mm push through grommet
Ingress protection:	IP65
Housing material:	High impact ABS (UL94V0 & 5VA)
Lens material:	High impact PC (UL94V0 f1)
Terminals:	0.5 to 1.5mm ²
Operating temp:	-25 to +50°C [-13° to +122°F]
Storage temp:	-40 to +70°C [-40° to +158°F]
Relative humidity:	90% at 20°C [68°F]
Weight:	184g/0.40lbs

*SPL data +/-3dB(A). Measured at optimum voltage.

*Candela measurements representative of performance with amber lens at optimum voltage.

Part Codes

Version:	Part code:
12-30V dc	H100BL030G/*
90-260V ac/dc	H100BL230G/*

* = L.E.D. colour: A: Amber, B: Blue, W: White (Clear lens), G: Green, R: Red, Y: Yellow

Horn Current Consumption

Version:	Voltage:	Current:
12-30V dc	12V dc	10mA
12-30V dc	24V dc	24mA
90-260V ac	115V ac 50/60Hz	19mA
90-260V ac	230V ac 50/60Hz	10mA

Beacon Current Consumption

Version:	Voltage:	Current:
12-30V dc	12V dc	74mA
12-30V dc	24V dc	80mA
90-260V ac	115V ac 50/60Hz	119mA
90-260V ac	230V ac 50/60Hz	32mA

Tone table

S 1 Description

T 1	800/1000Hz @ 7Hz Sweeping
T 2	Simulated buzzer sound
T 3	1200/500Hz @ 1Hz - DIN / PFEER P.T.A.P.

AUTHORIZED DISTRIBUTOR:
GasDetectorsUSA.com
Houston, Texas USA
sales@GasDetectorsUSA.com
832-615-3588