

# STExC1X05R Radial Alarm Horn & Xenon Strobe

**115dB(A) horn & 5 Joule Xenon.** The STExC1X05R is a high output alarm horn sounder with omni-directional radial horn combined with a 500,000cd Xenon strobe beacon. The robust IP66 316L stainless steel enclosure ensures the STExC1X05R is suitable for all IECEx & ATEX Zone 1, 2, 21 & 22 explosion proof signaling applications.

The alarm horn & Xenon strobe allow simultaneous or independent operation. Featuring 64 first stage/channel alarm sounds, the alarm tone frequencies for the first 2 stages are independently selectable. Each of the available 4 stage/channels can be remotely triggered e.g. via an external relay.

## Features

- Robust corrosion proof 316L stainless steel enclosure
- High output; up to 115dB(A)
- 4 remotely selectable alarm stages/channels
- Positive or negative line stage/channel switching
- Choice of 64 alarm tone frequencies
- User selectable strobe flash rates
- Field replaceable lens colour filter
- Automatic synchronisation on multi-beacon & sounder systems
- Continuously rated
- Compact form factor
- Stainless steel fixings
- Ratchet adjustable 316 stainless steel bracket
- 316 Stainless steel stopping plugs included
- 3 x cable entries
- Duplicate cable terminations (in & out for daisy-chain installations)
- Available with custom tone configurations and frequencies



## Approvals

- IECEx ULD 16.0017X  
IEC 60079-0 : 2011  
IEC 60079-1 : 2014  
IEC 60079-31 : 2013
- ATEX DEMKO 16 ATEX 1466X  
EN 60079-0 : 2012 + A11 : 2013  
EN 60079-1 : 2014  
EN 60079-31 : 2014
- TR-CU Ex EAC certificate: RU C-GB.AA71.B.00109

## Coding

- II 2G Ex db IIC Gb T6 Ta -50°C to +40°C
- II 2G Ex db IIC Gb T5 Ta -50°C to +55°C
- II 2G Ex db IIC Gb T4 Ta -50°C to +70°C
- II 2D Ex tb IIIC Db T110°C Ta -50°C to +70°C



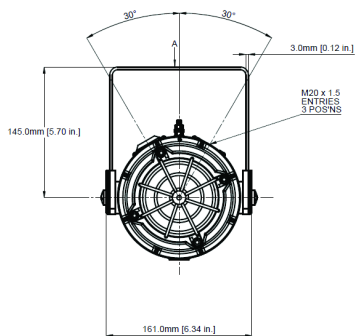
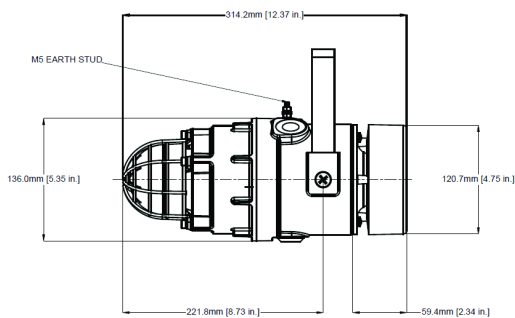

## Specification

### Alarm Horn:

Maximum output:	115dB(A) @ 1 metre [106dB(A) @ 10ft/3m]
Nominal output:	110dB(A) @ 1m +/- 3dB - Tone 2 [101dB(A) @ 10ft/3m]
No. of tones:	64 (UKOOA / PFEER compliant)
No. of stages:	4
Volume control:	Adjustable -12dB(A)
Effective range:	125m/410ft @ 1KHz
Supply Voltages:	24Vdc; 115Vac; 230Vac
Stage switching:	DC units: negative or positive AC units: common supply line

### Strobe Beacon:

Energy:	5 Joules (5Ws)
Flash rates:	Option 1: 1Hz (60 fpm) Option 2: 1.5Hz (90 fpm) Option 3: Double Strike
Peak Candela:	500,000 cd - calculated from energy (J)
Eff. Intensity:	250 cd - calculated from energy (J)
Peak Candela:	46,976 cd* - measured ref. to I.E.S.
Eff. Intensity:	143 cd* - measured ref. to I.E.S.
Lens colours:	Amber, Blue, Clear, Green, Magenta, Red & Yellow
Tube life:	Emissions are reduced to 70% after 5 million flashes

### General:

Ingress protection:	EN60529: IP66
Enclosure matl:	316L Stainless Steel
Enclosure finish:	Chromated & powder coated
Colour:	RAL3000 Red
Cable entries:	3 x M20 ISO (2 x stopping plugs included as standard) Adaptors to M25, 1/2" & 3/4" NPT can be specified
Terminals:	0.5 - 2.5mm <sup>2</sup> (20-14 AWG)
Enclosure volume:	<2 litres
Line monitoring:	Blocking diode included EOL Min. 500 Ohm 2w, or 3k3 Ohm 0.5w resistor or diode (DC versions) can be fitted
Grounding stud:	M5
Temperature range:	-50° to +70°C (-58°F to +158°F)
Relative humidity:	95% - Additional tronicalisation is recommended for

## Part Codes

<b>Version:</b>	<b>Part code:</b>
Product type:	STExC1X05
Horn type:	R Radial - omnidirectional horn
Voltage:	DC012 12V dc DC024 24V dc DC048 48V dc AC230 230V ac

Cable Entry Type:[e] A	3 x M20x1.5mm
B	2 x 1/2" NPT - adaptors
C	2 x 3/4" NPT - adaptors
D	2 x M25x1.5mm - adaptors
E	1 x 1/2" NPT - adaptor
F	1 x 3/4" NPT - adaptor
G	1 x M25x1.5mm - adaptor

Note: M20 stopping plugs for unused entries supplied

Adaptor/Stopping plug material: [m]	B Brass
N	Nickel Plated
S	Stainless Steel (standard)

Bracket/Guard material: [s]	1 A2 304 Stainless Steel
2	A4 316 Stainless Steel (default)
3	A2 304 St/St with Equip. Tag
4	A4 316 St/St with Equip. Tag (304)

Product version: [v] A1	IECEX & ATEX Group II 2G/D Zone 1, 2, 21 & 22
-------------------------	---

Enclosure colour: [x]	R Red RAL3000
-----------------------	---------------

Lens colour: [y]	A Amber
B	Blue
C	Clear
G	Green
M	Magenta
R	Red
Y	Yellow

Example part code: STExC1X05FAC230 [e][m][s][v][x]/[y]  
STExC1X05FAC230AS2A1R/R

## Current Consumption

Voltage:	Range:	Alarm Horn	Xenon Strobe	Com bined
12V dc	10-14Vdc	146mA	678mA	824mA
24V dc	20-28Vdc	185mA	323mA	508mA
48V dc	42-54Vdc	138mA	198mA	336mA
230V ac	220-240Vac 50/60Hz	21mA	79mA	106mA

Nominal current. Alarm horn soulder: Tone 2, Xenon Strobe: 1Hz Flash Rate

## Tone table

S 1	Description	S 2	S 3	S 4	S 1	Description	S 2	S 3	S 4
T1	1000 Continuous PFEER Toxic Gas	Any	T2	T44	T33	800 (0.25s on, 1.00s off) Intermittent	Any	T24	T8
T2	1200/500 @ 1Hz Sweeping DIN/PFEER P.T.A.P.	Any	T3	T44	T34	800 @ 2Hz (0.25s on, 0.25s off) IMO code 3.a ...	Any	T24	T8
T3	1000 @ 0.5Hz (1s on, 1s off) Intermittent PFE...	Any	T2	T44	T35	1000 @ 1Hz (0.50s on, 0.50s off) Intermittent	Any	T24	T8
T4	1.4KH-1.6KHz 1s, 1.6KHz-1.4KHz 0.5s NF C 48-265	Any	T24	T1	T36	2400 @ 1Hz (0.50s on, 0.50s off) Intermittent	Any	T24	T8
T5	544(100mS)/440 (400mS) NF S 32-001	Any	T19	T1	T37	2900 @ 5Hz (0.10s on, 0.10s off) Intermittent	Any	T24	T8
T6	1500/500 - (0.5s on , 0.5s off) x3 + 1s gap A...	Any	T44	T1	T38	363/518 @ 1Hz (0.50s/0.50s) Alternating	Any	T8	T19
T7	500-1500Hz Sweeping 2 sec on 1 sec off AS4428	Any	T44	T1	T39	450/500 @ 2Hz (0.25s/0.25s) Alternating	Any	T8	T19
T8	500/1200Hz @ 0.26Hz(3.3s on, 0.5s off) NEN 2575	Any	T24	T35	T40	554/440 @ 1Hz (0.50s/0.50s) Alternating	Any	T24	T19
T9	1000 (1s on, 1s off)x7 + (7s on, 1s off) IMO ...	Any	T34	T1	T41	554/440 @ 0.65Hz (0.76s/0.76s) Alternating	Any	T8	T19
T10	1000 (1s on, 1s off)x7 + (7s on, 1s off) IMO ...	Any	T34	T1	T42	561/760 @ 0.83Hz (0.60s/0.60s) Alternating	Any	T8	T19
T11	420(0.5s on, 0.5s off)x3 + 1s gap ISO 8201 Te...	Any	T1	T8	T43	780/600 @ 0.96Hz (0.52s/0.52s) Alternating	Any	T8	T19
T12	1000(0.5s on, 0.5s off)x3 + 1s gap ISO 8201 T...	Any	T1	T8	T44	800/1000 @ 2Hz (0.25s/0.25s) Alternating	Any	T24	T19
T13	422/775 (0.85 on, 0.5 off) x3 + 1s gap NFPA T...	Any	T1	T8	T45	970/800 @ 2Hz (0.25s/0.25s) Alternating	Any	T8	T19
T14	1000/2000 @ 1Hz - Singapore	Any	T3	T35	T46	800/1000 @ 0.875Hz (0.57s/0.57s) Alternating	Any	T24	T19
T15	300 Continuous	Any	T24	T35	T47	2400/2900 @ 2Hz (0.25s/0.25s) Alternating	Any	T24	T19
T16	440 Continuous	Any	T24	T35	T48	500/1200 @ 0.3Hz (1.67s/1.67s) Sweeping	Any	T24	T12
T17	470 Continuous	Any	T24	T35	T49	560/1055 @ 0.18Hz (2.73s/2.73s) Sweeping	Any	T24	T12
T18	500 Continuous IMO code 2 (Low)	Any	T24	T35	T50	560/1055 @ 3.3Hz (0.15s/0.15s) Sweeping	Any	T24	T12
T19	554 Continuous	Any	T24	T35	T51	600/1250 @ 0.125Hz (4s/4s) Sweeping	Any	T24	T12
T20	660 Continuous	Any	T24	T35	T52	660/1200 @ 1Hz (0.50s/0.50s) Sweeping	Any	T24	T12
T21	800 Continuous IMO code 2 (High)	Any	T24	T35	T53	800/1000 @ 1Hz (0.50s/0.50s) Sweeping	Any	T24	T12
T22	1200 Continuous	Any	T24	T35	T54	800/1000 @ 7Hz (0.07s/0.07s) Sweeping	Any	T24	T12
T23	2000 Continuous	Any	T3	T35	T55	800/1000 @ 50Hz (0.01s/0.01s) Sweeping	Any	T24	T12
T24	2400 Continuous	Any	T20	T35	T56	2400/2900 @ 7Hz (0.07s/0.07s) Sweeping	Any	T24	T12
T25	440 @ 0.83Hz (0.60s on, 0.60s off) Intermittent	Any	T44	T8	T57	2400/2900 @ 1Hz (0.50s/0.50s) Sweeping	Any	T24	T12
T26	470 @ 0.9Hz (0.55s on, 0.55s off) Intermittent	Any	T44	T8	T58	2400/2900 @ 50Hz (0.01s/0.01s) Sweeping	Any	T24	T12
T27	470 @ 5Hz (0.10s on, 0.10s off) Intermittent	Any	T44	T8	T59	2500/3000 @ 2Hz (0.25s/0.25s) Sweeping	Any	T24	T12
T28	544 @ 1.14Hz (0.43s on, 0.44s off) Intermittent	Any	T24	T8	T60	2500/3000 @ 7.7Hz (0.65s/0.65s) Sweeping	Any	T24	T12
T29	655 @ 0.875Hz (0.57s on, 0.57s off) Intermittent	Any	T44	T8	T61	800Hz Motor Siren	Any	T24	T12
T30	660 @ 0.28Hz (1.80s on, 1.80s off) Intermittent	Any	T24	T8	T62	1200Hz Motor Siren	Any	T24	T12
T31	660 @ 3.3Hz (0.15s on, 0.15s off) Intermittent	Any	T24	T8	T63	2400Hz Motor Siren	Any	T24	T12
T32	745 @ 1Hz (0.50s on, 0.50s off) Intermittent	Any	T24	T8	T64	Simulated Bell	Any	T21	T12