



Fireray® 3000

End-to-End Infrared Optical Beam Smoke Detector



The Fireray® 3000 system is an end to end infrared optical beam smoke detector (OBSD) which has been designed using the latest optical technology, incorporating modern industrial, electronic and software techniques. This detector offers cost effective protection of large, open area spaces with high ceilings. It is also very suited to applications where access to ceiling mounted smoke detectors presents practical difficulties.

The product is designed for applications where line of sight for the IR (infra-red) detection path is narrow and where the building structure uses reflective surfaces. It has also been designed to be aesthetically pleasing and thus can equally suit modern architectural buildings as well as historical sites, particularly where ornate ceilings exist. For installations complying with UL268/NFPA72, the maximum distance of Detector and Reflector from the ceiling must be 10% of the distance between floor and ceiling.

Engineering Specification

The projected beam type smoke detector shall be listed to U.L. 268 and shall consist of up to two transmitters, two receivers and a single low level remote control unit. The detector shall operate between a range of 16.5 ft. to 393 ft. (5m to 120m). The temperature range of the system shall be -4°F to 131°F (-20°C to 55°C). The receiver shall include an integral built-in laser pointer to assist in optimum alignment. The beam detector shall feature automatic gain control, which will compensate for gradual signal deterioration from dirt accumulation on the lenses. The receiver heads shall incorporate a Wide Field of View to ensure the unit is always receiving maximum signal available. The system shall include a low level remote display and control unit with LCD read-out for set-up, reporting and testing of up to 2 separate sets of heads. The system shall be capable of sending separate Trouble and Alarm signals for each of the sets of heads. The system shall be capable of programming alarm thresholds of 25% to 60% in 1% increments. The system shall be capable of programming delay to fault and delay to alarm from 2 seconds to 30 seconds in 1 second increments.

Features

- Separate Transmitter and Receiver Heads
- Range 16.5 to 393 feet, configurable per set of Detectors
- Lateral Spacing per NFPA 72 is 60 feet
- Integral Laser Alignment in Receiver
- 2-wire Interface between Controller and Receiver
- Single and Twin Channel capability
- Separate Fire and Fault Relays per Detector
- Low Level Controller with LCD display
- Programmable Sensitivity and Fire Threshold
- Automatic Gain Control (AGC) for drift compensation
- Built-in electronic UL/ULC obscuration-acceptance fire test
- Knockouts for ease of installation and wiring
- Built-in 1/2"/M-20 conduit knock-outs on detectors and system controller.

Test and acceptance of the system shall be carried out by using the UL/ULC approved internal electronic obscuration fire test. The projected beam type smoke detector shall be a 4-wire 24VDC device to be used with a Nationally Recognized Testing Laboratory's Listed and separately supplied 4-wire control panel. The End to End beam type smoke detector shall be a FFE Ltd. Fireray® 3000.

Installation Accessories

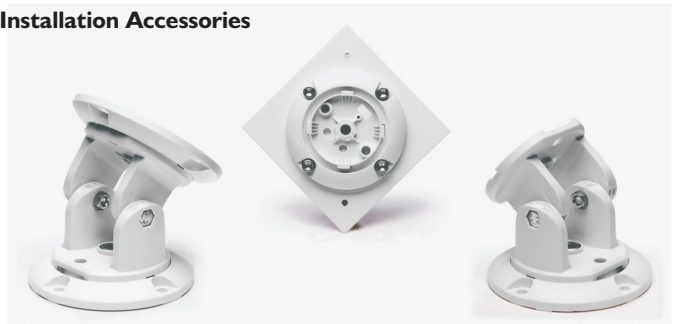

Construction Specification

Operating Range:	16.5 to 393 feet (5-120m)
Housing Material:	
(Transmitter/Receiver/Controller):	UL94 V2 PC
Maximum Cable Distance between Receiver & Controller:	330 Feet (100m)
Dimensions (W x H x D) & Weight:	
Control Unit -	7.99 x 4.88 x 2.81 in 203 x 124 x 71.5mm 1.34lbs (0.607kg)
Transmitter & Receiver -	3.07 x 3.03 x 6.33 in 78 x 77 x 161mm 0.456lbs (0.206kg)
Parts List (System):	1 x Transmitter (clear lens) 1 x Receiver (dark lens) 1 x Control Unit
Parts List (Additional Detector):	1 x Transmitter (clear lens) 1 x Receiver (dark lens)

Electrical Specification

Operating Voltage Range:	12 to 36V DC \pm 10%
Operating Controller Current (with 1 or 2 Receivers):	14mA (constant)
Operating Transmitter Current:	8mA (per Transmitter)
Alarm Threshold:	25%-60%
Power Down Reset Time:	>20 seconds
Fire and Fault Relay Contacts:	Resistive VFCO 2A @ 30 Volts DC
Operating Temp. (non-condensing):	-4°F to +131°F
UL -	(-20°C to +55°C)
Optical Wavelength:	850nm
IP Rating:	IP54
Relative Humidity (non-condensing):	93%
Cabling between each Receiver & Controller:	18-14 AWG 1-Pair Twisted, Jacketed
LED Indications:	
Control Unit - Red = Fire, Amber = Fault, Green = System OK	
Receiver - Red = Fire, Alignment LEDs for single person alignment.	

Listings

UL - S3417	ULC - S3417
CSFM - 7260-1508-105	FM Pending
Maryland - 2243	

Visit www.ffeu.com for up to date listings information.

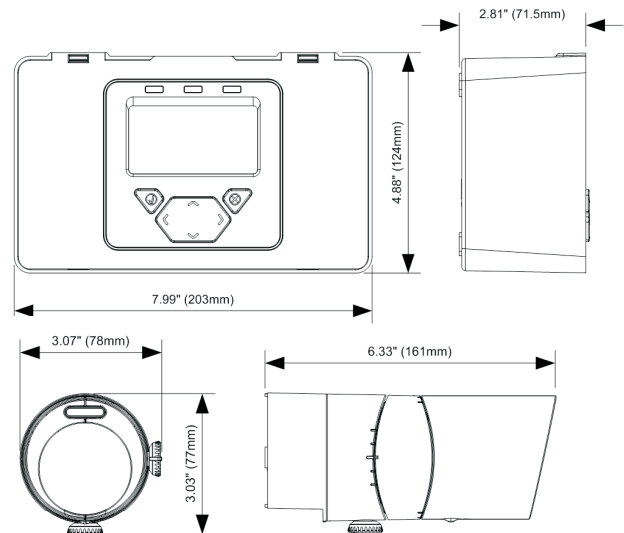

Ordering Information

3000-103: Fireray® 3000 End to End beam smoke detector
16.5ft. to 393ft. (5m to 120m).
System includes 1x Transmitter, 1x Receiver and 1x System Control Unit.
3000-016: Additional Detector Pack (set of Transmitter and Receiver heads).
Use up to 1 additional Detector Pack per 3000-103.
3000-201: Fireray® 3000 Adjustment Bracket
3000-202: Fireray® 3000 Surface Mount Adaptor
3000-203: Fireray® 3000 4" Square Cover Plate
5000-011: Fireray® 3000 Surface Mount Detector Back Box (Requires one 3000-202 Surface Mount Adaptor for each head - ordered separately).
3000-209: Fireray® 3000 Controller Back Box
3000-210: Fireray® 3000 Semi Flush Trim Plate
1000-018: Wire Cage for Fireray® 3000 when used with the 5000-011 Detector Back Box and 3000-202 (ordered separately).



AUTHORIED DISTRIBUTOR: GasDetectorsUSA.com
Houston, Texas USA
sales@GasDetectorsUSA.com
832-615-3588

Specifications and wiring information are provided for information only and are believed to be accurate. FFE Ltd assumes no responsibility for their use. Data and design are subject to change without notice. Installation and wiring instructions are shipped with the products and should always be used for actual installation. For more information, contact your Sales Representative.



Document Part No: 24-0017-08