

Ex nA, Weatherproof



Features

- Zone 2 use.
- Ex nA II T4.
- ATEX compliant, Ex II 3 GD.
- BASEEFA tested.
- IP66 & 67.
- Ambient temperature: -55°C to +55°C.
- 117dbA at 15 Watts at 1 metre.
- Power tapings via integral transformer.
- Stainless steel ratcheted swivel mounting stirrup.
- Stainless steel fixtures.
- 100V line or 8Ω.

Introduction

This loudspeaker, intended for use in Zone 2, potentially explosive gas and dust atmospheres, has a power rating of up to 15 Watts and is suitable for use in all gas groups including hydrogen.

The flare and body are manufactured from a UV stable glass reinforced polyester. Stainless steel screws and mounting stirrup are incorporated to ensure a corrosion-free product.

Authorized Distributor:
GasDetectorsUSA.com
Houston, TX USA
832-615-3588
sales@GasDetectorsUSA.com

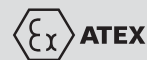

Specification

Certification:	CENELEC EN50014, 21. Ex nA II T 135°C (-55°C to +55°C) T4, Zone 2.
Material:	Body & horn in anti-static, UV stable, glass reinforced polyester. Mounting stirrup and fixtures in stainless steel.
Finish:	Natural Black or body and horn can be painted to client requirements.
Rated Power:	15 watts RMS continuous (at 25°C).
Certified Temp:	-55°C to +55°C.
Weight:	2.6kg approx.
Ingress Protection:	IP66 & IP67.
Entries:	2 x M20 ISO.
Terminals:	Up to 8 x 2.5mm ² .
Output:	Maximum output at 1W/1m at 900Hz is 107 dBA. Maximum output at 15W/1m at 900Hz is 117 dBA.
Frequency Range:	400Hz to 7kHz.
Voice Coil Impedance:	8 ohms.
Fire Retardancy:	GRP is fire retardant to ISO 1210.
Mounting:	Via stirrup with ratchet facility.
Earth Continuity:	Available.
Labels:	Optional stainless steel tag and duty labels.
Transformer:	Used by combining the rated power tappings below.

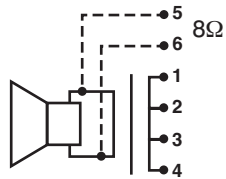
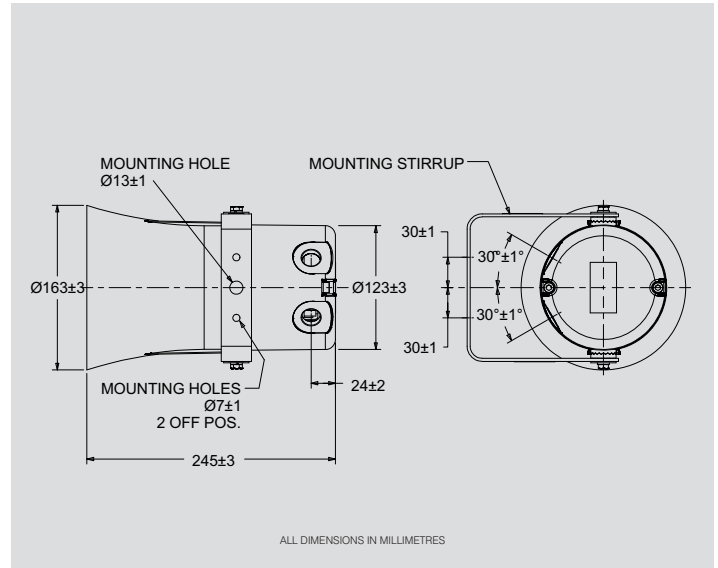

Transformer Tappings (Option (iii) shown)

Transformer Tappings	Power W
1:2	15.0
2:3	7.5
3:4	5.0
1:3	4.0
2:4	2.0
1:4	0.8

Transformer Options:

- Standard:**
- Loop in/Loop out (4 x 2) power tap change; 8 terminals.
- Optional:**
- Loop in/loop out (2 x 2) 8 ohm; 4 terminals.
 - 4 terminal tap change with 2 terminals (5 & 6), directly connected to driver (8 ohms).

Frequency Response @ 1W/1M for 15W Unit (1/3 Octave Pink Noise)

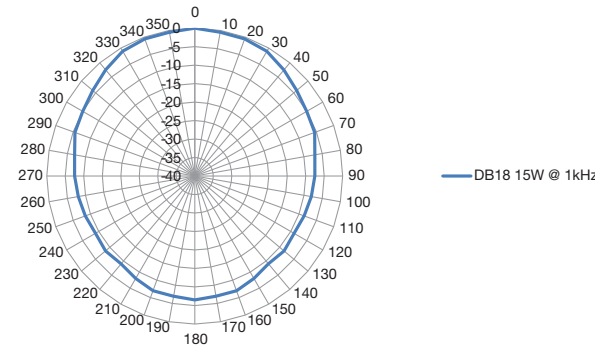
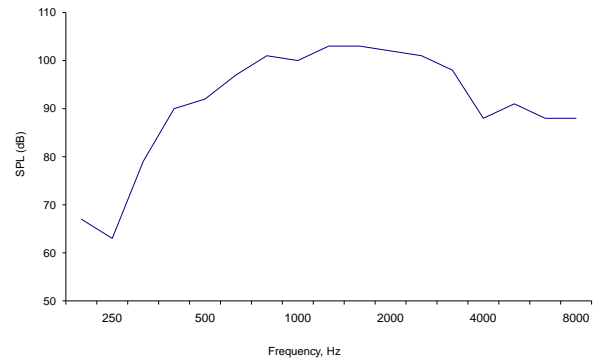

Ordering Requirements

The following code is designed to help in selection of the correct unit. Build up the reference number by inserting the pink code for each component into the appropriate box. **Standard products available ex-stock. Please visit www.coopermedc.com for further details.**

Model DB18	Transformer []	Option []	Finish []																												
	<table border="1"> <thead> <tr> <th>Transformer</th> <th>Code</th> </tr> </thead> <tbody> <tr> <td>Yes</td> <td>X*</td> </tr> <tr> <td>Transformer and 8 ohm terminals</td> <td>X8</td> </tr> <tr> <td>None (direct to driver)</td> <td>N</td> </tr> </tbody> </table>	Transformer	Code	Yes	X*	Transformer and 8 ohm terminals	X8	None (direct to driver)	N	<table border="1"> <thead> <tr> <th>Option</th> <th>Code</th> </tr> </thead> <tbody> <tr> <td>Duty label</td> <td>D*</td> </tr> <tr> <td>Tag label</td> <td>T*</td> </tr> <tr> <td>Earth continuity</td> <td>E</td> </tr> <tr> <td>Blanking Plug</td> <td>P</td> </tr> <tr> <td>None</td> <td>N</td> </tr> </tbody> </table>	Option	Code	Duty label	D*	Tag label	T*	Earth continuity	E	Blanking Plug	P	None	N	<table border="1"> <thead> <tr> <th>Finish</th> <th>Code</th> </tr> </thead> <tbody> <tr> <td>Natural Black</td> <td>N</td> </tr> <tr> <td>Red</td> <td>R</td> </tr> <tr> <td>Special</td> <td>S*</td> </tr> </tbody> </table>	Finish	Code	Natural Black	N	Red	R	Special	S*
Transformer	Code																														
Yes	X*																														
Transformer and 8 ohm terminals	X8																														
None (direct to driver)	N																														
Option	Code																														
Duty label	D*																														
Tag label	T*																														
Earth continuity	E																														
Blanking Plug	P																														
None	N																														
Finish	Code																														
Natural Black	N																														
Red	R																														
Special	S*																														

* Standard 100V
Other voltages available, specify voltage.

* Please specify wording

*Please specify