



# SenSmart 1000 Series



Show with Aluminum "AL" XP model



Shown with Non-metallic Poly "PY" Model



Shown with Stainless Steel Cover

The RC Systems **SenSmart 1100/1200/1300** are complete 2 or 3 wire Gas Detectors available in UL94 flame retardant plastic, or, Class 1 Div 1 316 stainless steel sensor head enclosures. These easy-to-install and maintain gas detectors must be connected to an R. C. Systems single or multi-channel receiver to add user calibration and readout functions. ([www.rcsystemsco.com/zoneprotector](http://www.rcsystemsco.com/zoneprotector)).

**SenSmart 1100** utilizes our electrochemical temperature controlled SMART sensors to transmit O<sub>2</sub>, H<sub>2</sub>S, SO<sub>2</sub>, Cl<sub>2</sub>, HF, HCL, NO<sub>2</sub> (to name a few) 2-wire 4-20mA gas values to R. C. Systems single and multi-channel receivers.

The **SenSmart 1200** utilizes our "bridge" sensors, including catalytic, PID and infrared, to detect methane, propane, VOC's, benzene, CO<sub>2</sub> and many other compounds. The **1200's** bridge output is compatible with R. C. Systems single and multi-channel receivers.

The **SenSmart 1300** has the same hardware as the **1100**, but utilizes our ultra-low power infrared SMART sensors to detect carbon dioxide (CO<sub>2</sub>), methane, propane and other hydrocarbons. The 2-wire output (8-20mA) transmits gas values to R. C. Systems receivers.

## FEATURES HIGHLIGHT

- Field swappable sensor module. Range and target gas configured on sensor module
- Improves system noise immunity because low level sensor signals are protected within the sensor head
- Industry standard 4-20mA signal may be transmitted thousands of feet on 2-wires
- 316 SS model is suitable for Class 1 Div 1 hazardous areas.
- Missing or failed sensor forces <2mA FAULT signal
- Compatible with 1, 2, 4, 16 and 64 channel Receiver/Controllers (user calibration & readout are at the Receiver)
- 2-wire milliamp signal is nonpolar with protective "steering diodes"

<b>Power Supply</b>	9-36 VDC @ 25mA
<b>Standard Output</b>	Standard 2-wire 4-20mA current sink . Max loop Resistance is 600 ohms with nominal 24VDC power supply
<b>Temp</b>	Less than .1% per degree C over ambient temperature range
<b>Housing</b>	316 Stainless or aluminum enclosure suitable for Class 1 Groups A,B,C,D; Class 2, Groups E,F,G
<b>Approval</b>	Division 1 and 2 Group A,B,C,D Exia. Suitable for Explosion Proof and Intrinsically Safe installations

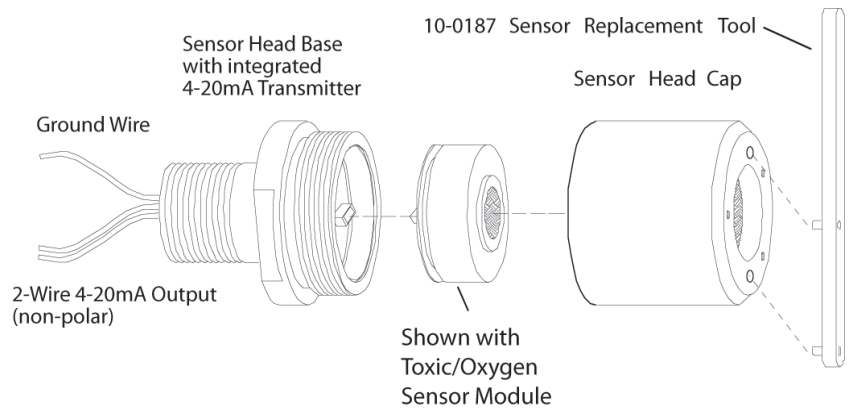
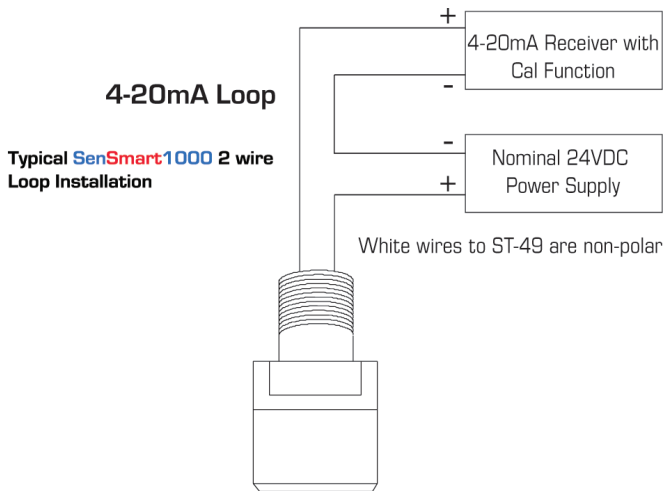

ALL DIMENSIONS IN INCHES

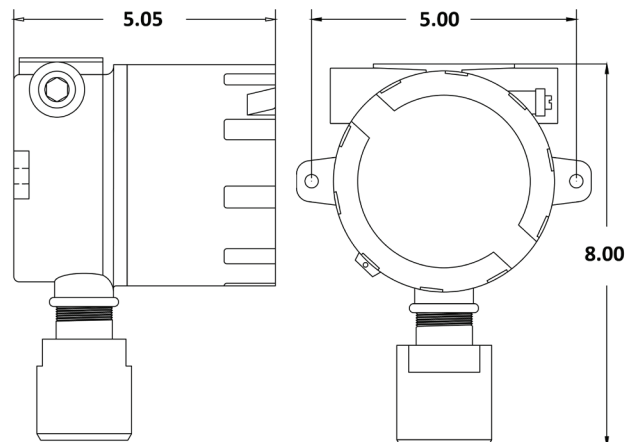
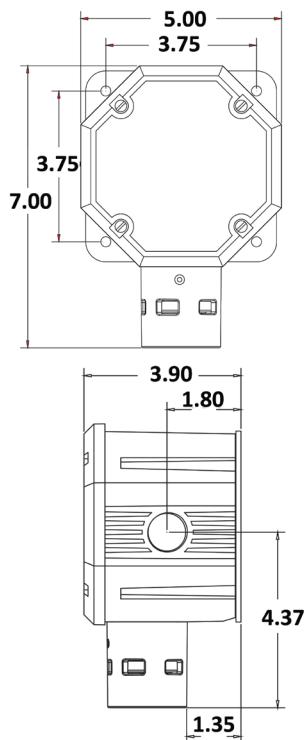

**AUTHORIZED DISTRIBUTOR:**  
 GasDetectorsUSA.com  
 Houston, Texas USA  
 sales@GasDetectorsUSA.com  
 832-615-3588