

Equipment assessed suitable for use in a SIL rated Safety Instrumented System

Type: Infrared Point Gas Detector
Product: GD10P
Reference: GD10-P00-*
Manufacturer: Simtronics AS
Developed by: Simtronics AS

Declaration Erklärung Declaración 合格声明 Декларация

Simtronics hereby confirms that the Infrared point gas detector GD10P is suitable for use in a SIL rated Safety Instrumented System (SIS). The equipment/module must be properly designed into a Safety Instrumented Function as a part of a loop designed to meet the SIL criteria for the function. A gas detector is defined as an initiator, and is typically, according to the OLF-Guideline No. 70, granted 35% of the total loop PFD.



Third party Verification:

Scandpower AS
P.O. Box 36, N-1300 Sandvika,
Norway
www.scandpower.com
Tel.: +47 922 47 100
Fax: +47 67 55 06 84

Reports

861-814819 Rev 02, 2012.11.15,
"Safety Analysis Report for
GD10P, PE, L"

Referenced documents

IEC 61508, "Functional Safety of
Electrical/
Electronic/Programmable
Electronic Safety-Related
System"
OLF-Guideline No. 70
Operating Manual Infrared
Point Gas detector GD10P 850-
811250

Data:

Assessment method	Proven in use
SIL-requirement	2 (and 3)
Configuration	1oo1 (HFT = 0)
Test interval, t	12 months
MTBF	515049 h
Safe Failure Fraction (SFF)	99,00%
Diagnostic Coverage (DC)	Close to 100%
λ_{TOT} (20°C)	$1,94 * 10^{-6}$
λ_{DU}	$1,94 * 10^{-8}$
Probability of Failures on Demand (PFD)	$8,49 * 10^{-5}$

Electrical:

Supply voltage	24 V DC, range 18-32 V DC
Power consumption	Approx. 3,5 W
Interface	Current source 4 – 20 mA
Load impedance	250 – 500 Ohm

Environment:

Temperature	-40°C to +65°C
Humidity	100% RH
Protection	IP66/IP67 DIN 40050



Simtronics AS
Kabelkaten 8, Økern Næringspark
P.O. Box 314 Økern
NO-0511 Oslo, Norway
Tel. +47 22 64 50 55
Email: mail@simtronics.no

Simtronics SAS
792, av de la Fleuride
BP 11016,
13781 Aubagne Cedex – France
Tel. +33 (0) 442 180 600
Email: contact@simtronics.fr



This document is the property of Simtronics ASA and must not be copied, shown, or in any way be communicated to persons other than those requiring the information for the execution of their duty.

Dette dokumentet er Simtronics ASAs eiendom og må ikke kopieres, fremvises eller på annen måte meddeles andre enn de som trenger disse opplysningene for utførelsen av sine plikter.

Document No. 861-814819

Safety Analysis Report for GD10P,PE,L

Document code or file name:
(Mandatory if Document No. is not used):

SDM-75742 - Safety Analysis Report (SAR)

REVISION

DOC REVISION	DATE	CN	DESCRIPTION OF CHANGE (Alternatively, use last page for descriptions. CN N/A for non-released documents.)	Sign.
00	04.02.05			
01	07.09.26	07	Updated with additional information as FMEA, reference list and MTBF number	HK

DOC. REVISION	PREPARED	VERIFIED	APPROVED
01	Name: Steinar Lind Title: Dev.Eng. Sign:	Name: Kristina Arianson Title: Consultant / Scandpower Sign:	Name: Arvid Bjerkestrand Title: R&D Manager Sign:

Scandpower
Risk Management AS
P.O. Box 3, N-2027 Kjeller, Norway
www.scandpower.com
Tel.: +47 64 84 44 00
Fax: +47 64 84 44 11

I. ABBREVIATIONS AND DEFINITIONS

λ_{SD}	Lambda Safe Detected
λ_{SU}	Lambda Safe Undetected
λ_{DD}	Lambda Dangerous Detected
λ_{DU}	Lambda Dangerous Undetected
λ_{TOT}	Lambda Total
CCF	Common Cause Failure
DC	Diagnostic Coverage
E/E/PE	Electric/Electronic/Programmable Electronic
FMEA	Failure Mode Effect Analysis
FMECA	Failure Mode Effect Criticality Analysis
HWT	Hardware Fault Tolerance
IEC	International Electrotechnical Commission
IR	Infrared
LEL	Lower Explosion Level
MTBF	Mean Time Between Failures
MTTR	Mean Time To Repair
N/A	Not Applicable
OREDA	Offshore Reliability Data
PbSe	Lead selenide
PCS	Production Control System
PFD	Probability of Failure on Demand
PLC	Programmable Logic Controller
PSF	Probability of Systematic Failures
SAR	Safety Analysis Report
SFF	Safe Failure Fraction
SIL	Safety Integrity Level
SIS	Safety Instrumented System
SRS	Safety Requirement Specification

Definitions are based on the definitions in IEC 61508 - Part 4.

II. REFERENCES

- /1/ IEC 61508: "Functional Safety of Electrical/Electronic/Programmable Electronic Safety-Related System", IEC 1998.
- /2/ OLF-Guideline No. 70, Rev. 02, October 2004.
- /3/ Scandpower Risk Management AS: "Firewater Pump on Ormen Lange", Report No. 21.312.120/R1, January 2006
- /4/ Simrad Optronics Operating Manual GD10P P3359E . Doc no: 850-811250
- /5/ SINTEF report STF48 F92011

Test Documents:

871-811215	Test procedure for General adjustment and control GD10P
871-810867	Test procedure for Final Test GD10P 100% LEL CH4 5s source
870-810960	Factory Acceptance Test General Gas Detector GD10
803-810782	Software Requirement Specification Screen/PC, GD10
803-810783	Software Specification Screen/PC, GD10
872-810628	Test Procedure Power & Processing Assembly GD10

Certified Standards:

Standard	Description
EN 50014 (1977) IEC 60079-0	Electrical apparatus for potentially explosive atmospheres. General requirements
EN 50018 (1977) IEC 60079-1	Electrical apparatus for potentially explosive atmospheres. Flame-proof enclosure "d".
EN 50019 (1977) IEC 60079-7	Electrical apparatus for potentially explosive atmospheres. Increased safety "e".
EN 50054 (1991)	Electrical apparatus for the detection and measurement of combustible gases. General requirements and test methods.
EN 50057	Performance requirements for Group II apparatus indicating up to 100% lower explosive limit.
EN 50081-1	Electromagnetic compatibility - Generic emission standard
EN 50081-2	Electromagnetic compatibility - Generic immunity standard.
CSA C22.2 no.142-M1987	Process Control Equipment
CSA C22.2 no.152-M1984	Combustible Gas Detection Instruments
CAN/CSA E79-0:02	Electrical apparatus for explosive gas atmospheres. Part 0.
CAN/CSA E79-1:02	Electrical apparatus for explosive gas atmospheres. Part 1
CAN/CSA E79-7:02	Electrical apparatus for explosive gas atmospheres. Part 7

Certificates:

Certificates
ISO 9001 Simrad-Optronics ASA
ISO 9001 Simtronics ASA (Company name after demerging in Jan. 2007)
Nemko01Atex163Q
Nemko01Atex282
Nemko00Atex138x
SIRA Certificate of Conformity No. Ex 97Y8025
ABS 99-056882-X
AUSEX 2393
UL- E219548
CSA 1773527

Software References:

Program Specification
Software Safety Requirements

Doc no 803-810784 Ver 6
Doc no 803-810663

III. SUMMARY

Table 1 - Total failure rate

Component	$\lambda_{TOT, 30^{\circ}C, \text{Ground Fixed}}$	$\lambda_{TOT, 10^{\circ}C, \text{Ground Fixed}}$	MTBF	
			10°C 90909h	30°C 64850h
Power and Processor Assembly	$1.51 \cdot 10^{-5}$	$1.07 \cdot 10^{-5}$	10°C 90909h	30°C 64850h
Optical Unit	$0.029 \cdot 10^{-5}$	$0.03 \cdot 10^{-5}$		
Total	$1.54 \cdot 10^{-5}$	$1.10 \cdot 10^{-5}$		

Table 2 - Summary

Summary	
SIL-requirement	3
Test Interval	12 (months)
Safe Failure Fraction	99,97 (%)
λ_{DU}	$0,0034651 \cdot 10^{-6}$
PFD	$1,5 \cdot 10^{-5}$

Table 3 - Main Results

Requirements		Main results
Safety Integrity Level	SIL 3 / SIL 2	The SAR documents that the SIL-requirement is achieved.
Probability of Failure on Demand (PFD)	0.001	The results of the reliability calculations show that the PFD requirement is met. $PFD_{SIL2} < 0.001$ $PFD_{GD10} = 0,15 \cdot 10^{-4}$ The PFD result shows that the GD10 is in compliance with the requirement of 35% of SIL 3 and thereby also SIL 2.
Required test interval	Yearly	12 months

Requirements		Main results
System description	System description System topology and block diagram Operational description of the system	A thorough system description of the components has been given, with reference to GD10 Operation Manual, Ref. /4/. An FMEA has been completed for the GD10. This analysis is attached in Appendix C.
Failure rate of the components	Failure rates: $\lambda_{SD}, \lambda_{SU}, \lambda_{DD}, \lambda_{DU}$	The failure rates (safe detected, safe undetected, dangerous detected and dangerous undetected) of the components have been determined by sub-suppliers and used in the probability calculations (DC, SFF and PFD).
Common Cause Failure (CCF)	CCF must be included for all redundant components	N/A for GD10
Diagnostic Coverage (DC) and Safe Failure Fraction (SFF)	Calculate DC and SFF	The DC and SFF are calculated by using the determined failure rates.
Behaviour of system component on detection of a fault	Document fault behaviour	Ref. Chapter 9
Factory testing	Test documents required	Ref. Chapter 10
Operational testing	Test documents required	Ref. Chapter 11
Architectural constraints	Hardware Fault Tolerance	The requirement for hardware fault tolerance is met for SIL 3/ SIL2.
Avoidance and control of systematic failure	"Proven in use" certified	The GD10, GDPE and GD10 L can be considered proven in use. ISO Certificate and product reference list are included in appendix B.
Software documentation	Software	Ref. Chapter 14

TABLE OF CONTENTS

I. ABBREVIATIONS AND DEFINITIONS

II. REFERENCES

III. SUMMARY

1. INTRODUCTION

- 1.1 General
- 1.2 Scope of Work

2. SYSTEM DESCRIPTION

- 2.1 General
- 2.2 Construction
- 2.3 Gas data

3. SYSTEM TOPOLOGY AND BLOCK DIAGRAM

- 3.1 Block Diagram

4. OPERATIONAL DESCRIPTION OF THE SYSTEM

- 4.1 Installation
 - 4.1.1 Mounting
 - 4.1.2 Electrical Connections
- 4.2 Start-up procedure

5. ASSUMPTIONS

- 5.1 Restrictions

6. FAILURE RATE OF THE COMPONENTS

- Failure Data from Repair Statistics
- Dangerous Undetected Failures

7. COMMON CAUSE FAILURES

8. DIAGNOSTIC COVERAGE & SAFE FAILURE FRACTION

9. BEHAVIOUR OF SYSTEMS/COMPONENTS ON DETECTION OF A FAULT

10. FACTORY TESTING

11. OPERATIONAL TESTING

12. ARCHITECTURAL CONSTRAINTS

- 12.1 General

13. AVOIDANCE AND CONTROL OF SYSTEMATIC FAILURES

14. SOFTWARE DOCUMENTATION

15. RESULTS

Appendix A: Failure Rate Data

Appendix B: An extract of the reference list and certificates

Appendix C: FMEA for GD10

1. INTRODUCTION

1.1 General

The GD10P was qualified for production in 1997. Development of the detector took place in the period 1994 to 1997. After 1997, more than 35.000 units of the GD10P have been installed.

The GD10P was developed as a successor to the GD100. The aim of the development was to bring forward a more compact unit at a smaller cost. The core technology of the GD100 and the GD10P is identical. The vital components such as the IR-source and the PbSe-detector remained identical together with the mechanical arrangement of the components and the optical system. Signal conditioning and signal philosophy was also kept. The reason for not altering any of the above, was the proven performance and long term stability of the GD100 together with solely positive feedback from customers, notified bodies and test houses. State of the art electronic components at that time (e.g. surface mounted components) were however chosen to replace older technology in order to reduce cost and size. The new electronic components all have a higher safety level and longer component-life than the older, replaced components.

A Safety Instrumented Function is defined by three elements, as shown in Figure 1. The percentages represent the fracture of SIL level required from each element.

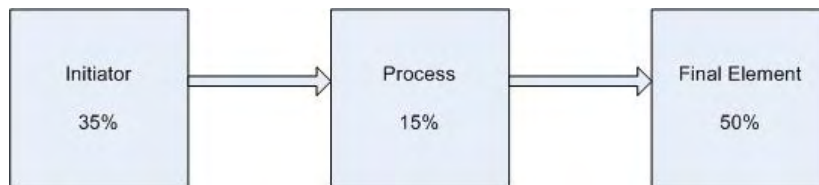

Figure 1 - Safety Instrumented System

The gas detector is defined as an initiator in an SIS.

This loop requires a SIL 2 level, where the initiator represents 35%, the process 15% and the final element 50%, according to the OLF 070 guideline, Ref /2/. With the SIL 2 level between $1 \cdot 10^{-2}$ and $1 \cdot 10^{-3}$, this means that the gas detector needs to meet with the requirement of a PFD below $3.5 \cdot 10^{-3}$.

1.2 Scope of Work

The SAR is part of the vendor documentation from the engineering and construction phase and contains information regarding how Simtronics, as a vendor, has implemented the requirements set by IEC 61508/61511, the OLF Guideline 070 and the SRS.

- IEC 61508-2 clause 7.4.7.3 lists information that shall be available for each safety-related subsystem and hence documented in the SAR
- IEC 61511-1 clause 11.9.2 lists information that shall be taken into account when calculating the PFD due to hardware failures and hence documented in the SAR
- The SAR layout suggested in the OLF Guideline 070, Chapter E.3 has been used. This SAR is based on the requirements to SAR given in the OLF Guideline, Ref. /2/.

2. SYSTEM DESCRIPTION

The information in this chapter refers to the GD10 Operating Manual, chapters 1 and 2, Ref. /4/, if nothing else stated.

2.1 General

The Simtronics GD10 Gas Detector is a point detector for gas concentration monitoring in potentially hazardous and/or poisonous environments. The GD10 is based on infrared absorption and uses the latest developments in analogue and microprocessor technology. Solid state design improves reliability, long-term stability and accuracy in continuous measurement of gas concentration in ambient air.

The concept is based on measurement of infrared radiation passing through a volume of gas. The GD10 employs a dual beam, dual wavelength measuring principle with separate optical detectors for maximum stability and reliability.

Since different types of gas have unique absorption spectra, they can easily be identified by proper selection of an infrared wavelength at which absorption is measured. Radiation at another wavelength measures the overall transmission through the optical system and the air volume. By comparing the transmission at the two wavelengths, the gas concentration in the air is determined. Having chosen a wavelength which is characteristic of one type of gas, other types of gas will not cause false alarms.

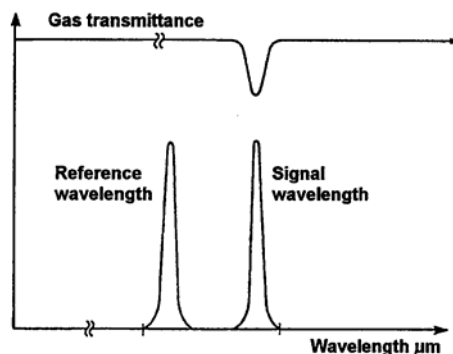

Figure 2- Transmittance as a function of wavelength

Radiation from two infrared sources passes through two narrowband filters selecting a measuring wavelength and a reference wavelength. The sources are electronically chopped. Radiation is divided by a beamsplitter into an internal and external path. The internal path is viewed by the compensation detector, and the external path is viewed by the measuring (main) detector.

The four signals, two from the compensation detector and two from the main detector, are amplified, digitised and fed to the microprocessor. The signals are used by the microprocessor to calculate the gas concentration. The gas response is then linearized and presented as either voltage, current or digital output signal. Internal signals are compared with test limits to monitor electronics and optical parts.

Optical filter characteristics remain constant over time, and drift in the other components is monitored and compensated by the dual wavelength, dual path concept. This means that the zero and gas span factory calibration will remain stable regardless of component drift, and that the detector needs no manual recalibration after factory calibration.

2.2 Construction

A complete GD10 Gas Detector consists of the following:

- An external gas measuring path where gas is measured by means of IR radiation. A weather protection enclosure is mounted around the measuring path to protect the optical surfaces from rain and dust.
- An optoelectronic unit, which generates IR radiation to the gas measuring path, measures the reflected IR radiation from the gas measuring path and calculates the gas concentration. This unit is enclosed by an EExd certified housing.
- A terminal compartment with cable entry and mini-terminals for electrical connection. The compartment is protected by a cover and is EExe certified.

2.3 Gas data

The GD10 standard version is factory calibrated and linearized with methane gas in the 0-100% LEL range. Calibration/linearization to other gases or concentrations can also be done. Accurate measurements can only be achieved by having the detector calibrated for the gas it is intended to measure. Gases such as ethane, propane and butane are also detected by the GD10. A GD10 calibrated for methane has a higher sensitivity to these gases than to methane. This means that explosion danger from other HC-gases will always be detected by the GD10.

3. SYSTEM TOPOLOGY AND BLOCK DIAGRAM

3.1 Block Diagram

The purpose of the System Topology is to show the architectural relationship between the identified systems with components critical to the given function. Figure 3 shows the family tree of the GD10 and Figure 4 shows a block diagram describing the function of the GD10. The information regarding the System Topology refers to GD10 Operating Manual, Ref. /4/.

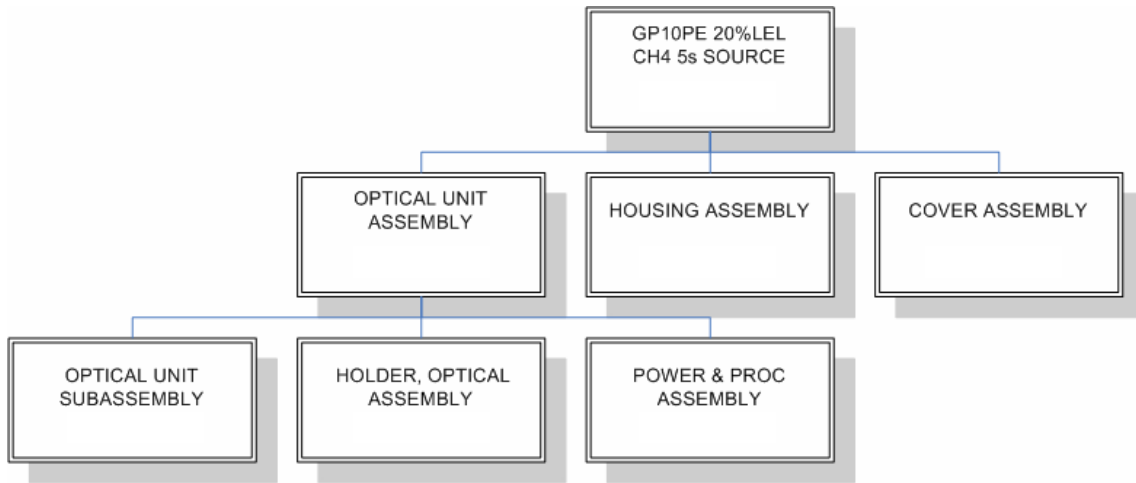

Figure 3 - Family tree of the GD10

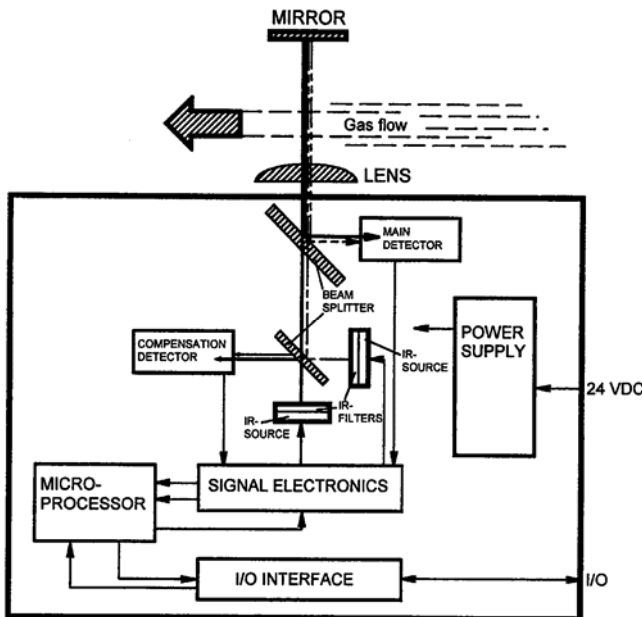

Figure 4 - Block diagram, GD10

4. OPERATIONAL DESCRIPTION OF THE SYSTEM

4.1 Installation

The information in this chapter refers to the GD10 Operating Manual, Ref. /4/, chapters 3, 4 and 5 if nothing else stated.

4.1.1 Mounting

The location of each detector should preferably be determined at the system design stage.

Choice of mounting area:

1. The detector should be mounted where the gas leakage is most likely to occur. To detect methane, which is lighter than air, inside an enclosed area the detector should be mounted high in the area to be protected or immediately above potential leaking sites.
2. To detect gases heavier than air, e.g. propane, the detector should be mounted below the potential leaking site.
3. The detector should be mounted in a place where maintenance, i.e cleaning of the optics, is easily performed.
4. The detector may be mounted in areas where no oxygen is present.
5. The detector may be mounted in areas with strong airflow.
6. The detector should NOT be mounted where it could be exposed to water drenching.

If installed in a ventilation duct or pipe, the mounting arrangement and accessories shown in Figure 5 and Figure 6 should be used.

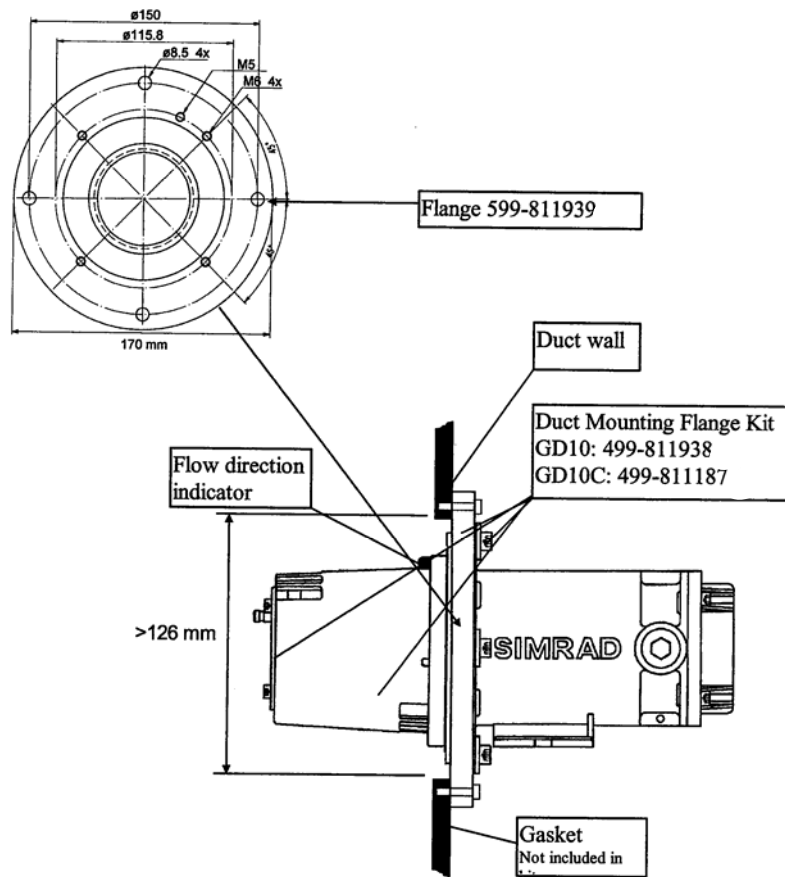

Figure 5 - Ventilation duct or pipe mounting

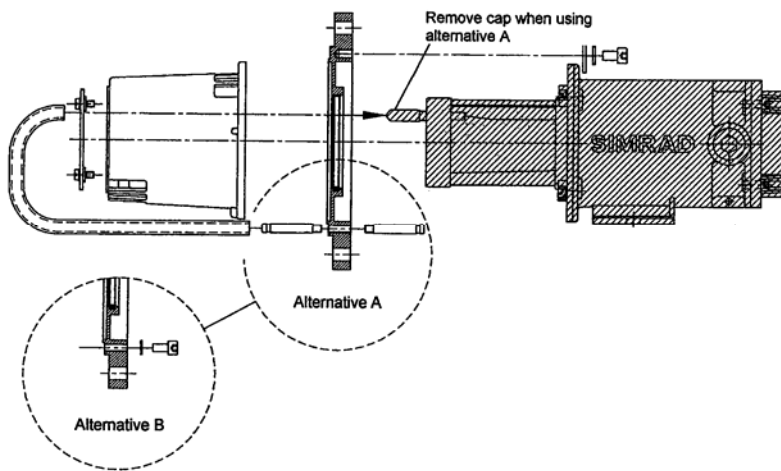

Figure 6 - Ventilation duct or pipe mounting

In order to achieve minimum response time, the Weather Protection must be oriented with the flow direction indicator facing away from the air flow.
 The sensor must be mounted in straight parts of the duct where air flow is laminar. Avoid mounting the sensor in duct bends and places where the air flow is turbulent.

The detector should be mounted so that the longitudinal axis of the detector is horizontal. This will prevent accumulation of water and dust on the optics. The Weather Protection must always be oriented correctly for optimal performance, and is performed as follows:

- Use a screwdriver to loosen the two screws on the Weather Protection
- Rotate the Weather Protection to correct position
- Tighten the screw with a torque of max. 0.5 Nm

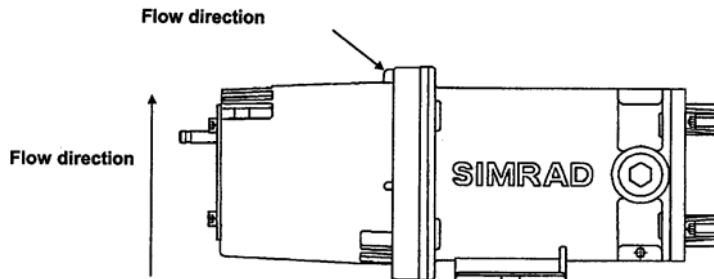
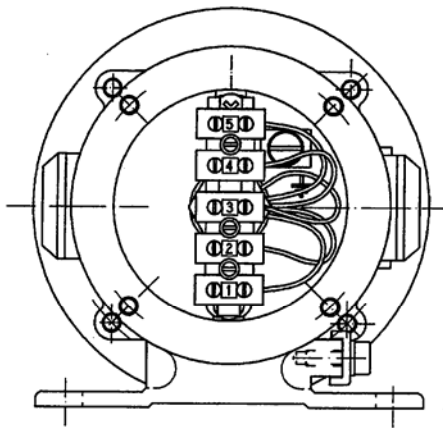

Figure 7 - Orientation of GD10 in relation to flow direction

4.1.2 Electrical Connections

The terminal compartment is accessible by removing the circular terminal cover. The terminal compartment, including the 5 mini-terminals for electrical connection, is shown below in Figure 8.



Terminal 1 +24 V DC
 Terminal 2 24 V return (0 V)
 Terminal 3 4-20 mA output

Terminal 4 Not used
 Terminal 5 Not used

Figure 8 - Terminal compartment

The installation wiring enters the terminal compartment via a single M20 EExe cable gland, which can be mounted on either side of the compartment. The unused entry is blanked with an EExe cover.

The detector has two output modes which are factory set:

- Current source 4-20 mA (standard)
- Current sink 4-20 mA (option)

The cable connections are as follows:

Terminal No 1: +24V DC

Terminal No 2: 0V DC (24V and signal return)

Terminal No 3: Signal output

The shield of the cable should be connected to instrument earth in the central control module.

4.2 Start-up procedure

Ensure that system wiring and control system are in working order before switching on power to the detector. The detector will then perform self-test and internal signal adjustments lasting for approximately 60 seconds and switch to measuring mode.

The output signal from the detector during this period is shown in Figure 9. Signal output before 60 seconds is 0 mA, and signal output after 60 seconds is 4 mA (if no gas is present).

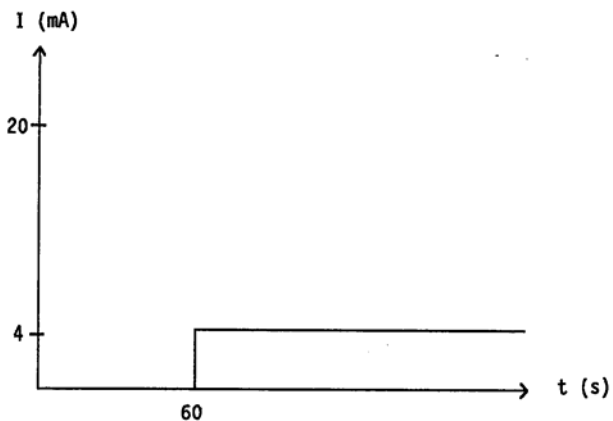

Figure 9 - Signal output during start-up period

5. ASSUMPTIONS

It is assumed that the operation and maintenance are performed in accordance with the procedures described in Simtronics Operating Manual, Ref. /4/.

5.1 Restrictions

Hydrocarbon gases such as methane, ethane, propane and butane are absorbing at a signal wavelength of 3.3 μm . These gases do not interfere at the reference wavelength at 3.0 μm . If the atmosphere to be monitored contains gases such as acetylene that absorb at the reference wavelength of 3.0 μm , misleading measurements may be obtained depending on the interfering gas concentration. In such cases, contact Simtronics for information.

6. FAILURE RATE OF THE COMPONENTS

The Failure Rates used are shown in Appendix A.

The following gives a brief presentation of the concepts and methodology used for the SIL verification process:

The input parameters used in the calculations are:

λ : Total failure rate. Retrieved from MIL-HDBK, see Appendix A.

τ : Test interval. Established based on typical operational philosophy.

The dangerous failure rate (λ_D) used to calculate the PFD, is calculated based on the total failure rate (λ_{TOT}).

Dangerous failures are defined as dangerous undetected failures (undetected by diagnostics test) and dangerous detected failures (detected by diagnostics test). In the calculations the dangerous failures are the registered number of failures with failure modes defined as dangerous. Each failure mode of the equipment in question has been categorized as "Safe" or "Dangerous" based on their effect on the system/component. Based on this the number of safe failure and dangerous failures is found.

The Probability of Failure on Demand is given by:

$$PFD = \frac{\tau \cdot \lambda_{DU}}{2} + \lambda_{CommonCause}$$

The given λ is λ_{TOT} , and includes all failures, not only hazardous failures.

Component	λ_{TOT} , 30°C, Ground Fixed	λ_{TOT} , 10°C, Ground Fixed	MTBF	
			10°C 90909h	30°C 64850h
Power and Processor Assembly	$1.51 \cdot 10^{-5}$	$1.07 \cdot 10^{-5}$	10°C 90909h	30°C 64850h
Optical Unit	$0.029 \cdot 10^{-5}$	$0.03 \cdot 10^{-5}$		
Total	$1.54 \cdot 10^{-5}$	$1.10 \cdot 10^{-5}$		

Failure Data from Repair Statistics

The following data is retrieved from Simtronics' repair statistics, which is data collected from all repairs performed on GD10 from 01.01.2005 to 30.06.2007. All gas detectors with faults should be delivered to Simtronics for maintenance in accordance with the Operation Manual, Ref. /4/.

The statistics in the table below shows the type of faults on the GD 10 detected by repair at Simtronics.

No. of GD10 sold from 1997 through 30.06.2007: More than 35 000

Period 01.01.2005 to 30.06.2007 (2.5 years)

Total detectors returned to Simtronics: 2,65 % of total sold

Total repairs of returned detectors: 72,15 % (No Faults Found removed)

Detector elements:	17,68 % of total repairs
IR Sources:	3,10 % of total repairs
PCB	12,82 % of total repairs
Other	27,53 % of total repairs
Re-Zero adjustment	40,35 % of total repairs

Returned detectors with No Fault Found: 27,85 %

Clean Optics: 4,19 % of total returned (Included in No Faults Found)

Please note that a detector may have more than one fault.
None of the faults reported was of the dangerous undetected failure.

As shown, there have not been any reports of dangerous undetected failure of the GD10.

Dangerous Undetected Failures

An FMEA of the gas detector has been performed, see Appendix C. From the identified failure modes, only two Dangerous Undetected modes were identified:

- Freeze of the output signal at a certain level >4mA in the Output Electronics
- Drive voltage failure in sink output

In order for the output signal to freeze at a critical level, transistor Q5A, transistor Q10 or the controller U11A on the external interface must fail. U18A in the CPU may also cause this failure mode.

There are four causes for such a failure; rupture of gate, drain or source, or partly conductivity between drain and source. Of these four, only the last will result in an undetected failure.

Hence, the dangerous undetected failure rate for these components may be assumed 1/4th of the total failure rate. In addition, the failure rates may be corrected by other factors, see Table 0.1.

Table 0.1: Dangerous Undetected Failure Rates

Component	Total Failure Rate, Ref. Appendix	Correction Factor	λ_{DU}
Q5A	$0,20827 \cdot 10^{-6}$	0,25 (1 of 4 failure modes is dangerous) x 0,0167 (Only a failure resulting in resistance output between 2,08 - 3,75 kOhm is dangerous. The output range is 100 kOhm ¹) = 0,004175	$0,000869 \cdot 10^{-6}$
Q10	$0,21793 \cdot 10^{-6}$	0,25 (1 of 4 failure modes is dangerous) x 0,0167 (Only a failure resulting in resistance output between 2,08 - 3,75 kOhm is dangerous. The output range is 100 kOhm) = 0,004175	$0,0009098 \cdot 10^{-6}$
U11A	$0,03176 \cdot 10^{-6}$	0,25 (1 of 4 failure modes is dangerous) x 0,04166 ((Only a failure in 1 V interval will be dangerous. Total range is 24 Volt.) = 0,0104	$0,0003303 \cdot 10^{-6}$
U18C	$0,02712 \cdot 10^{-6}$	0,25 (1 of 4 failure modes is dangerous) x 0,2 (Only a failure in 1 V interval will be dangerous. Total range is 5 Volt.) = 0,05	$0,001356 \cdot 10^{-6}$
Total Dangerous Undetected Failure Rate:			$0,0034651 \cdot 10^{-6}$

If the detector is in the sink mode, the voltage is supplied by the customer. Assuming that the supplied voltage is 100 % reliable, the argumentation and calculation for this failure mode will be as for the freeze mode.

Hence, the total dangerous undetected failure rate is **$0,0034651 \cdot 10^{-6}$ per hour.**

¹ Assuming a low level alarm at 20% of full range

7. COMMON CAUSE FAILURES

There are not identified any common cause failures for the GD10, GDPE or GD10L.

8. DIAGNOSTIC COVERAGE & SAFE FAILURE FRACTION

The Safe Failure Fraction (SFF) is the safe fraction of failures, which can be considered "safe" because they are detected by diagnostic tests or do not cause loss of safety function.

The safe failure fraction is the ratio of non-critical failures (safe failures + dangerous detected failures) of the system divided to the total number of failure recorded.

$$sff = \frac{\# \text{ Safe failures}}{\# \text{ Failures recorded}} = 1 - \frac{\# \text{ Dangerous failures}}{\# \text{ Failures recorded}}$$

An FMEA of the GD10 has been performed, and is attached in Appendix C. The FMEA divided the system into the following sub-systems:

1. Microprocessor unit
2. Watchdog
3. Chopper Electronics
4. Output Electronics
5. Signal Electronics Including Detector
6. Power Supply

From the identified failure modes, only two Dangerous Undetected modes were identified:

- Freeze of the output signal at a certain level >4mA in the Output Electronics
- Drive voltage failure in sink output

These two failure modes are the only modes identified by the FMEA participants to be a possible source of an undetected dangerous failure, i.e. a failure leading to the detector not detecting gas when in fact gas is present. However, for freezing of the output signal to occur, the output will have to stick in a position of between 4mA and the lowest alarm level of the detector. Such a failure is considered extremely unlikely to happen. Sink voltage failure is also very unlikely and can only occur in the sink type detectors, not in the source type.

The Diagnostic Coverage (DC) is assumed to be close to 100%.

The Safe Failure Fraction (SFF) is 99,97 %.

9. BEHAVIOUR OF SYSTEMS/COMPONENTS ON DETECTION OF A FAULT

The internal microprocessor performs continuous self-testing of optical and electronic functions. If a fatal error should occur in the electronics or optics, the processor will generate a 0 mA output signal, indicating sensor failure.

The Dangerous Undetected and Safe Detected failures determined in the FMEA session, see Appendix Y, are listed in the table below.

Table 4 - Failure Causes

Failure	Failure causes
Dangerous Undetected Failures	Freeze of the output signal at a certain level >4mA and <lowest alarm level causing failure of the output transistor or one of the other components on the output card. The effect would be wrong indication of gas concentration at a level between 0% and up to an alarm level.
	Drive voltage failure in sink output caused by failure in drive voltage. The output will not be able to show more voltage than a certain level, e.g. 5mA.
Safe Detected Failures	Failure of voltage supply caused by component failure in power supply. The effect would be voltage output to zero. Failure detected by external and internal supervision of voltage.
	CPU freeze caused by Software failure, unstable voltage levels, or hardware failures. The effect would be system out of operation and no program execution. Failure detected by external and internal supervision of voltage.
	I/O read/write error caused by failure of one or more of the inputs/outputs. This will lead to system out of operation. Microprocessor will indicate failure of I/O.
	Loss of pulse generation, either at zero or a constant value caused by failure of transistor or failure of gate between the microprocessor and the source. The effect would be Loss of function; the output will go to zero. Detected by microprocessor, output will go to zero.
	Freeze of the output signal out of range caused by failure of one of the components on the output card leading to Stop of function, output to zero.
	No signal to the microprocessor caused by component failure in the signal electronics or failure of the detector (converting the IR light to electrical signal). This will lead to loss of signal to the microprocessor and loss of function of the system. Detected by the microcontroller, zero output.
	Distorted signal to the microprocessor caused by component failure in the signal electronics or failure of the detector (converting the IR light to electrical signal). Failure effect will be that the range of the detector shifts from 4mA. Detected by the microcontroller, zero output.

Failure	Failure causes
	<p data-bbox="579 186 1320 310">Wrong voltage from the voltage regulators caused by too low range on the voltage, too high voltage or signal noise. The effect will be a distorted signal. Detection by the microcontroller which will set the output to zero.</p> <p data-bbox="579 319 951 352">Internal supervision of voltage.</p> <p data-bbox="579 361 1333 485">No voltage from the voltage regulators caused by failure of components in the voltage supply. The effect would be loss of function of the system. Detection by the microcontroller which will set the output to zero. Internal supervision of voltage.</p>

10. FACTORY TESTING

Testing is documented in the following procedures:

- 871-811215.3 Test procedure for General adjustment and control GD10P
- 871-810867.2 Test procedure for Final Test GD10P 100% LEL CH4 5s source
- 870-810960.5 Factory Acceptance Test General Gas Detector GD10
- 803-810782.3 Software Requirement Specification Screen/PC, GD10
- 803-810783.1 Software Specification Screen/PC, GD10
- 872-810628.8 Test Procedure Power & Processing Assembly GD10

11. OPERATIONAL TESTING

The operational testing section refers to chapters 4 and 5 in the Operating Manual for GD10, Ref /4/.

Upon failure indication, the detector should be tested according to Figure 10 below.

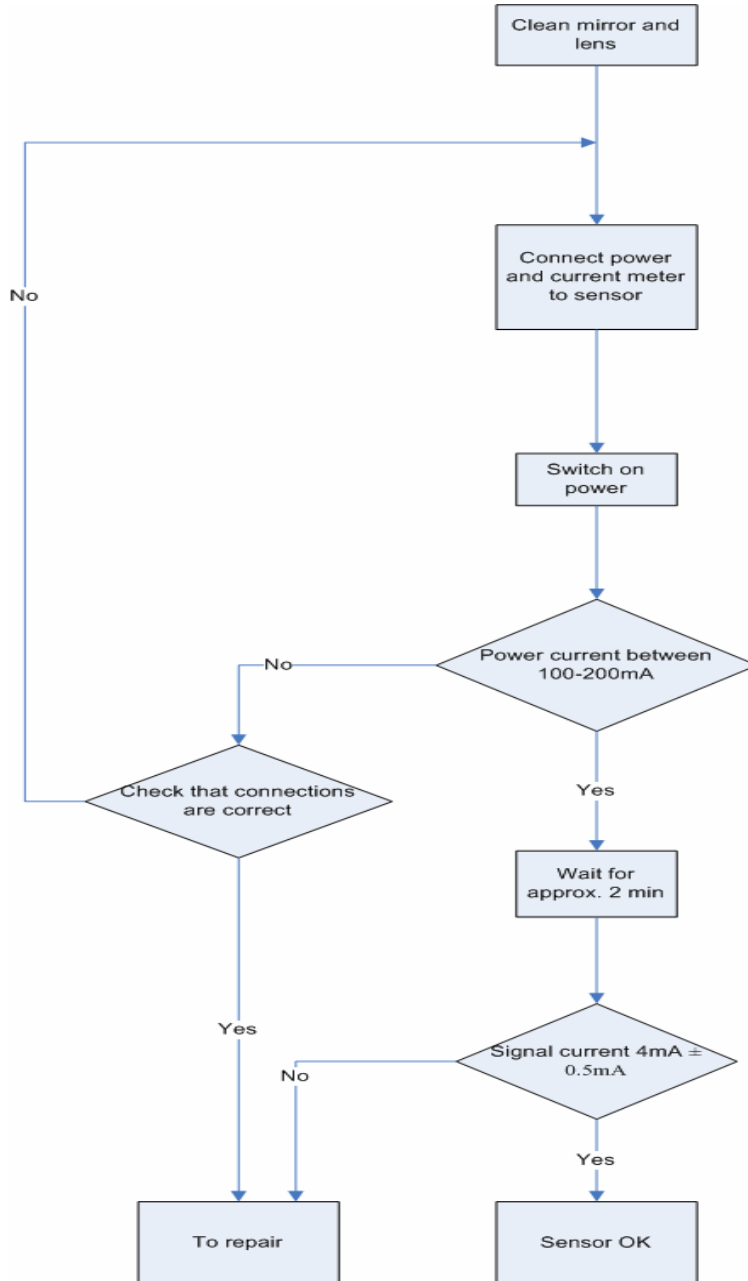

Figure 10: Test procedure

In addition, a functional test should be performed at commissioning and when the detector is replaced.

The functional test of the GD10 can be performed as follows:

- If there is no air movement, a test gas flow of a minimum 4 litres/minute will give approximately the same value as the test gas.
- If there is an air movement of 0.5 m/sec, the test gas flow must be increased to 20 litres/minute to show the same value.
- At high air velocities, when it is difficult to obtain sufficient output using test gas in the LEL area, a test gas in the 50-100% vol. range can be employed. This gas can be applied at high flow for 2-5 seconds to acquire a concentration of test gas in the gas measuring path for a short period.

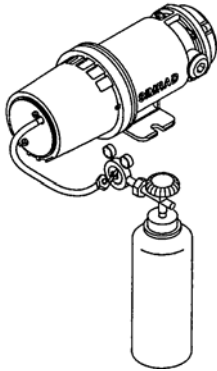

Figure 11 - Set-up of functional test

In principle, there is no need for a Calibration test due to the fact that the detector is calibrated at the factory and it can be proved by empirical data that the calibration does not change over time.

The GD10P has been designed to require a minimum of maintenance and functional testing. The only necessary maintenance is to inspect visually that the Weather Protection is not clogged in heavily contaminated areas. The design of the GD10P does not require functional test at certain intervals, but some customers still choose to perform functional test in relation with functional testing of other equipment, even though this is not necessary or commended from Simtronics.

12. ARCHITECTURAL CONSTRAINTS

12.1 General

The Hardware Fault Tolerance (HFT) requirements for an E/E/PE safety-related system containing type B sub-systems is given in IEC 61508 -2, sub clause 7.4, Ref. /1/.

A type A sub-system is in IEC 61508 terminology a system where all possible failure modes can be determined for all constituent components. For type B sub-systems, the behaviour under fault conditions can not be completely determined for at least one component (e.g. a logic solver).

The GD10 Gas Detector is a type B system as it contains software in form of a micro processor.

Table 5 - Hardware Safety Integrity: Architectural Constraints on Type B Safety-related Sub-systems (IEC 61508-2, Table 3)

Safe failure fraction	Hardware fault tolerance		
	0	1	2
< 60 %	Not allowed	SIL 1	SIL 2
60 % - 90 %	SIL 1	SIL 2	SIL 3
90 % - 99 %	SIL 2	SIL 3	SIL 4
> 99 %	SIL 3	SIL 4	SIL 4

The GD10 is assumed to be a type B sub-system, and thus follows the HFT from Table 5. With a safe failure fraction of 99,97%, this system has a hardware fault tolerance of 0, and thus meets with a SIL 3, and thereby also a SIL 2, requirement.

13. AVOIDANCE AND CONTROL OF SYSTEMATIC FAILURES

Systematic faults are faults in hardware and software introduced during specification, design, operation or maintenance/testing, which may result in the failure of the safety function under certain conditions, e.g. for particular input signal states. These failures are, unlike random hardware faults, not quantified in IEC 61058/61511 methodology. In order to avoid and control this category of failures it is required in IEC 61508 that certain techniques and measures shall be used to avoid and control this category of failures.

The standard has adopted a qualitative approach to address the implementation of the measures. The respective requirements concerning hardware and software are given in IEC 61508-2 and IEC 61508-3. The standard provides tables that specify in which areas/processes systematic failures must be addressed. The tables define the required effectiveness of the techniques applied, and the importance of using the different measures is also specified. A great variety of techniques can be applied and the standard provides examples/recommendations in IEC 61508-7.

According to IEC61508-2 clause 7.4.4 and 7.4.5 the requirement related to avoidance and control of systematic failures will not apply to a subsystem considered "proven in use". The term "proven in use" is defined by clause 7.4.6 to 7.4.12 in IEC 61508-2.

A component can be considered proven in use if it can comply with the following:

The set of data must be based on:

- More than 10 inventories or more than 50 critical failures
- More than 50000 hours calendar / operational time
- More than 2 installations covered
- More than one operator covered

An extract of the reference list is attached in Appendix **B** together with the ISO certificate. The full reference list can be obtained by request.

The GD10 has been certified according to the requirements for "Electrical apparatus for explosive atmospheres" given by CENELEC in the standards described in Table 6.

Table 6 - Certified standards

Standard	Description
EN 50014 (1977)	Electrical apparatus for potentially explosive atmospheres. General requirements
	Amendment No. 1 (July 1979)
	Amendment No. 2 (June 1982)
	Amendment No. 3 (December 1982)
	Amendment No. 4 (December 1982)
	Amendment No. 5 (February 1986)
IEC 60079-0	Electrical apparatus for potentially explosive atmospheres. General requirements 2000
EN 50018 (1977)	Electrical apparatus for potentially explosive atmospheres. Flame-proof enclosure "d".
	Amendment No. 1 (July 1979)
	Amendment No. 2 (December 1982)
	Amendment No. 3 (November 1985)

Standard	Description
IEC 60079-1	Electrical apparatus for potentially explosive atmospheres. Flame-proof enclosure "d". 2001
EN 50019 (1977)	Electrical apparatus for potentially explosive atmospheres. Increased safety "e".
	Amendment No. 1 (July 1979)
	Amendment No. 2 (September 1983)
	Amendment No. 3 (December 1985)
IEC 60079-7	Electrical apparatus for potentially explosive atmospheres. Increased safety "e". 1990 + A1, 1991 + A2, 1993.
EN 50054 (1991)	Electrical apparatus for the detection and measurement of combustible gases. General requirements and test methods.
EN 50057	Performance requirements for Group II apparatus indicating up to 100% lower explosive limit.
EN 50081-1	Electromagnetic compatibility - Generic emission standard
	Part 1: Residential, commercial and light industry
EN 50081-2	Electromagnetic compatibility - Generic immunity standard.
	Part 2: Industrial Environment

Certificates are listed in Table 7.

Table 7 - Certificates

Certificates
ISO 9001 Simrad-Optronics ASA
ISO 9001 Simtronics ASA (Company name after demerging in Jan. 2007)
Nemko01Atex163Q
Nemko01Atex282
Nemko00Atex138x
SIRA Certificate of Conformity No. Ex 97Y8025
ABS 99-056882-X
AUSEX 2393
UL- E219548
CSA 1773527

14. SOFTWARE DOCUMENTATION

Documentation for the micro processor can be found in the Program Specification, document no 803-810784.9 version 6, and the Software Safety Requirements, document no 803-810663.5.

Please contact Simtronics to view these documents.

15. RESULTS

Summary	
SIL-requirement	2/3
Test Interval, τ	12 (months)
Safe Failure Fraction, SFF	99,97 %
Diagnostic Coverage	Close to 100 (%)
λ_{DU}	$0,0034651 \cdot 10^{-6}$ (failures / hr)
PFD	$0,15 \cdot 10^{-4}$

To obtain the SIL requirement of 2, the PFD for the safety instrumented system (SIS) needs to lie between $1 \cdot 10^{-2}$ and $1 \cdot 10^{-3}$. Based on numbers from the OLF guidelines, Ref /2/, the gas sensor needs to obtain a PFD below 35% of the total PFD of the SIS, i.e. a PFD below $3.5 \cdot 10^{-3}$. As shown in the Summary Table above, the PFD of the GD10 is well within this range. Thus the 35% of a SIL 2 requirement is achieved. The GD10 has a HFT of 0, and an SFF of 99,97%.

Appendix A: Failure Rate Data

16.66H
MilStress V3.31

14:37:52 02-DEC-96 Page 1

MIL-STD-217F NOTICE 1 PART STRESS PREDICTION

Standard Report

Project Name : SO-GD10

Block : 1 Gasdetector GD10
 Description : Power & Processing Assembly
 Analyst : SA
 Environment : CF
 Amb. Temperature : 50

Description	Part Number	Circuit Reference	No. Off	Block/Comp. Fail. Rate	Total Fail. Rate	% Contrib
2 External Interface			1	2.63357	2.63357	17.40
2 Powersupply			1	5.64308	5.64308	37.29
5 Sensor Amplifier			1	3.23762	3.23762	21.39
				3.62011	3.62011	23.92

- = component non-compliant with MIL-HDBK-217

Block F/R = 15.13438 fpmh
 15134.38 fits

Block MTBF = 66075. Hrs.

Block Component Total = 0

WilStress V3.31

WIL-HDBK-217F NOTICE 1 PART STRESS PREDICTION

Standard Report

Project Name : SD-GD10

Block : 2 External Interface
 Description :
 Analyst :
 Environment : GF
 Amb. Temperature : 30

Description	Part Number	Circuit Reference	No. Off	Block/Comp. Fail. Rate	Total Fail. Rate	% Contrib
Connection, Reflow Solder			126	.00014	.01739	.66
CHIP RESISTOR, 1-100koha, 0805, 0.125W,	201-903XXX.A	GENERAL RESISTORS	22	.02051	.45113	17.13
CER. CHIP CAP., 47nF, 50V, X7R, 0805,	210-903774.8	C49	1	.09682	.09682	3.68
CER. CHIP CAP., 47nF, 50V, X7R, 0805,	210-903774.8	C5	1	.01784	.01784	.68
CER. CHIP CAP., 47nF, 50V, X7R, 0805,	210-903774.8	C50	1	.01720	.01720	.65
CER. CHIP CAP., 6.8nF, 50V, X7R, 0805,	210-904105.4	C15,C16,	2	.07827	.15655	5.94
CER. CHIP CAP., 330pF, 50V, NPO, 0805,	210-904110.4	C107,	1	.02960	.02960	1.12
CER. CHIP CAP., 330pF, 50V, NPO, 0805,	210-904110.4	C8,C9,C10,C11,	4	.00426	.01706	.65
CER. CHIP CAP., 330nF, 25V, X7R, 1206,	210-904111.2	C100,	1	.02763	.02763	1.05
CER. CHIP CAP., 1uF, 25V, Y5V, 1206,	210-904114.6	C102,	1	.03121	.03121	1.19
TRANS., PNP, LF, BC856B, SOT-23,	241-903534.6	Q12,	1	.00326	.00326	.12
TRANS. MOS-FET, DUAL, N-CH, NDS9945,SO-8	241-903758.1	Q5,	1	.32397	.32397	12.30
TRANS. MOS-FET, N-CH, 2N7002, SOT-23,	241-904005.6	Q10,	1	.33705	.33705	12.80
DIODE, RECT., BYD17G, 400V, 1.5A, SOD87,	242-904006.4	D3,D13,D14,	3	.01300	.03901	1.48
DIODE, TRANSORB-BIDIR, SW6T15CA, 33V,600W	243-903999.1	D17,D18,	2	.07163	.14325	5.44
DIODE, TRANSORB-BIDIR, SW6T33CA, 33V,600W	243-904000.7	D19,D20,	2	.07163	.14325	5.44
DIODE, ZENER, 12V, BZX84-C12, SOT-23,	243-904004.9	D4,D5,	2	.11673	.23346	8.86
PREC. QUAD. OP-AMP, TLE2024IDW, SO-16W,	244-903992.6	U11,	1	.03930	.03930	1.49
RS485 LINE TRANSCIEIVER, ADM485JR, SO-8,	244-903997.5	U12,	1	.08921	.08921	3.39
PINHEADER, 2x4PIN, STRAIGHT,	370-903565.0	P3,	1	.08543	.08543	3.24
RIBBONE CABLE JUMPER, 13P,	380-904142.7	W1,	1	.11709	.11709	4.45
RIBBONE CABLE JUMPER, 2P,	380-904143.5	W2,W3,W4,W5,	4	.05319	.21277	8.08
INTERNAL CONNECTION ASSEMBLY	INTA2		1	.00410	.00410	.16

* = component non-compliant with WIL-HDBK-217

Block F/R = 2.63357 fpmh
 2633.57 fits

Block MTBF = 379713. Hrs.

Block Component Total = 34

WilStress V3.31

14:37:52 02-DEC-96 Page 3

WIL-HDBK-217F NOTICE 1 PART STRESS PREDICTION

Standard Report

Project Name : SO-GD10

Block : 3 Powersupply
 Description :
 Analyst :
 Environment : GF
 Amb. Temperature : 30

Description	Part Number	Circuit Reference	No. Off	Block/Comp. Fail. Rate	Total Fail. Rate	% Contrib
Connection, Reflow Solder			169	.00014	.02332	.41
CHIP RESISTOR, 1-100koha, 0805, 0.125W,	201-903XXX.A	GENERAL RESISTORS	22	.02051	.45113	7.99
CHIP RESISTOR, 1-100koha, 1206, 0.25W,	201-903XXX.C	GENERAL RESISTORS	4	.02051	.08202	1.45
CHIP RESISTOR, 0.22ohm, 5%, 1206, 0.25W,	201-904146.8	R14	1	.02051	.02051	.36
CER. CHIP CAP., 1nF, 50V, 0805,	210-903523.9	C118,C120,	2	.01778	.03555	.63
CER. CHIP CAP., 1nF, 50V, 0805,	210-903523.9	C119,	1	.03415	.03415	.61
CER. CHIP CAP., 1nF, 50V, 0805,	210-903523.9	C121,	1	.01168	.01168	.21
CER. CHIP CAP., 1nF, 50V, 0805,	210-903523.9	C7,	1	.06339	.06339	1.12
CER. CHIP CAP., 47nF, 50V, X7R, 0805,	210-903774.8	C1,C134,C140,C143,	4	.09682	.38729	6.86
CER. CHIP CAP., 47nF, 50V, X7R, 0805,	210-903774.8	C130,C135,C142,C110,	4	.01784	.07134	1.26
CER. CHIP CAP., 47nF, 50V, X7R, 0805,	210-903774.8	C131,C137,	2	.23569	.47137	8.35
CER. CHIP CAP., 47nF, 50V, X7R, 0805,	210-903774.8	C139,	1	.02839	.02839	.50
CER. CHIP CAP., 100pF, 50V, NPO, 0805,	210-904108.8	C4,C116,	2	.00286	.00573	.10
CER. CHIP CAP., 180pF, 50V, NPO, 0805,	210-904109.6	C112,	1	.00317	.00317	.06
CER. CHIP CAP., 470pF, 50V, NPO, 0805,	210-904112.0	C6,C111,	2	.00356	.00712	.13
CAP., ELYT., RAD., LONG-LIFE, 220uF, 50V	213-904008.0	C128,	1	.26516	.26516	4.70
CAP., ELYT., RAD., LONG-LIFE, 470uF, 35V,	213-904009.8	C123,	1	.17778	.17778	3.15
CAP., ELYT., RAD., HI-REL., 470uF, 50V,	213-904010.6	C144,	1	.31648	.31648	5.61
CAP., ELYT., RAD., HI-REL, 1000uF, 25V,	213-904011.4	C145,	1	.19367	.19367	3.43
CAP., ELYT., RADIAL, 10uF, 63V,	213-904012.2	C114,	1	.13061	.13061	2.31
CAP., ELYT., RADIAL, 10uF, 63V,	213-904012.2	C124,C125,	2	.17023	.34046	6.03
CAP., ELYT., RADIAL, 10uF, 63V,	213-904012.2	C3,	1	.12878	.12878	2.28
CAP., ELYT., RAD., LONG-LIFE, 100uF, 63V	213-904013.0	C127,	1	.17333	.17333	3.07
CAP., ELYT., RAD., HI-REL, 2200uF, 10V,	213-904158.3	C146,	1	.22320	.22320	3.96
CAP., ELYT., RAD., 100uF, 16V,	213-904160.9	C17,C115,	2	.23044	.46088	8.17
INDUCTOR, RADIAL, 100uH, 1A, 92mohm,	220-903555.1	L1,	1	.04344	.04344	.77
INDUCTOR, RADIAL, 47uH, 1.5A,	220-904139.3	L3,	1	.04344	.04344	.77
INDUCTOR, RADIAL, 100uH, 660mA,	220-904140.1	L5,	1	.04344	.04344	.77
CHIP INDUCTOR, 10uH, 550mA, 1812,	222-903517.1	L6,L8,	2	.04344	.08687	1.54
TRANS., NPN, LF, BC846B, SOT-23,	241-902818.4	Q4,	1	.00377	.00377	.07
TRANS., PNP, LF, BC855B, SOT-23,	241-903534.6	Q3,	1	.00223	.00223	.04
TRANS. MOS-FET, N-CH, RIK483-60A, SOT-223	241-904003.1	Q6,	1	.37982	.37982	6.73
DIODE, HS SWITCHING, BAS16, SOT-23,	242-903536.1	D2,	1	.01348	.01348	.24
DIODE, RECT., BYD17G, 400V, 1.5A, SOD87,	242-904006.4	D15,	1	.04336	.04336	.77

* = component non-compliant with MIL-HDBK-217

Continued on Next Page.

MilStress V3.31

14:37:52 02-DEC-96 Page 4

MIL-HDBK-217F NOTICE 1 PART STRESS PREDICTION

Standard Report

Project Name : SO-GD10
 Block 3 ...continued

RECT. DIODE, SCHOTTKY, 100V, 1A, MBR51100	242-904007.2	CR1,	3	.02362	.07085	1.26
RECT. DIODE, SCHOTTKY, 100V, 1A, MBR51100	242-904007.2	CR3,	1	.02071	.02071	.37
RECT. DIODE, SCHOTTKY, 100V, 1A, MBR51100	242-904007.2	CR4,	1	.01481	.01481	.26
DIODE, TRANZORB-BIDIR, SM6T33CA, 33V, 600W	243-904000.7	D25,	1	.07163	.07163	1.27
DIODE, ZENER, 12V, BZX84-C12, SOT-23,	243-904004.9	D1,	1	.11673	.11673	2.07
DC-DC CONVERTER CONTROL, MC33063AD, SO-8,	244-903556.9	U14,	1	.13838	.13838	2.45
DC-DC CONVERTER CONTROL, MC33063AD, SO-8,	244-903556.9	U15,	1	.13173	.13173	2.35
POWER CONTROLLER, MIC38C43BM, SO-8,	244-903985.0	U13,	1	.10839	.10839	1.92
VOLT. REG., LM317L, SO-8,	244-903987.6	U16,	1	.11024	.11024	1.95
SW. VOLT. CONVERTER, LMC7661W, SO-8,	244-904161.7	U1,	1	.09076	.09076	1.61
INTERCONNECTION ASSEMBLY	INTA3		1	.00246	.00246	.04

○ = component non-compliant with MIL-HDBK-217

Block F/R = 5.64308 fpmh
 5643.08 fits

Block MTBF = 177208. Hrs.

Block Component Total = 82

MilStress V3.31

MIL-HDBK-217F NOTICE 1 PART STRESS PREDICTION

Standard Report

Project Name : SO-GD10

Block : 4 CPU
 Description :
 Analyst :
 Environment : GF
 Amb. Temperature : 30

Description	Part Number	Circuit Reference	No. Off	Block/Comp. Fail. Rate	Total Fail. Rate	% Contrib
Connection, Reflow Solder			218	.00014	.03008	.93
CHIP RESISTOR, 1-100kohm, 0805, 0.125W,	201-903XXX:A	GENERAL RESISTORS	31	.02051	.63569	19.63
CHIP THERMISTOR, NTC, 2.2kohm, 1206,	204-904014.8	R150,	1	.10500	.10500	3.24
CHIP CAP., 47nF, 50V, X7R, 0805,	210-903774.8	C52,53,56,58,59 etc.	9	.01935	.17414	5.38
CER. CHIP CAP., 47pF, 50V, NPO, 0805,	210-904106.2	C147,C148,	2	.00224	.00448	.14
CER. CHIP CAP., 330nF, 25V, X7R, 1206,	210-904111.2	C101,	1	.02454	.02454	.76
CER. CHIP CAP., 330nF, 25V, X7R, 1206,	210-904111.2	C2,C13,C14,	3	.02136	.06408	1.98
CER. CHIP CAP., 1uF, 25V, Y5V, 1206,	210-904114.6	C103,C104,	2	.02497	.04993	1.54
CER. CHIP CAP., 1uF, 25V, Y5V, 1206,	210-904114.6	C12,	1	.03121	.03121	.96
CER. CHIP CAP., 100nF, 50V, X7R, 1206,	210-904115.3	C149,	1	.01938	.01938	.60
CER. CHIP CAP., 470nF, 50V, 1206,	210-904173.2	C105,	1	.30362	.30362	9.38
CHIP INDUCTOR, 10uH, 180mA, 1210,	222-904141.9	L16,L17,	2	.04344	.08687	2.68
QUARTZ CRYSTAL, 4.0MHz, HC49/4H,	230-904149.2	X2,	1	.11266	.11266	3.48
DIODE, DUAL, HS SWITCHING, BAV99, SOT-23	242-903998.3	D28,D29,	2	.01348	.02696	.83
8-BIT uCONTROLLER, 87C196, PLCC-68,	244-810872.2	U17,	1	1.19489	1.19489	36.91
LOW-DROP VOLT. REGULATOR, LP2951AC, SO-8	244-903986.8	U2,	1	.09066	.09066	2.80
uP SUPERVISORY MONITOR, MAX809L, SOT-23,	244-903994.2	U21,	1	.04112	.04112	1.27
HCMS 74HC08, SO-14,	244-903995.9	U18,	1	.02880	.02880	.89
SERIAL EEPROM, 128x8 BIT, 24C01, SO-8,	244-903996.7	U19,	1	.18344	.18344	5.67
LED, DUAL, GREEN-RED, SOT-23	245-903567.6	D27,	1	.00663	.00663	.20
SOCKET PLCC-68,	370-904148.4	E01,	1	.01768	.01768	.55
IN CONNECTION ASSEMBLY	INTA4		1	.00574	.00574	.18

* = component non-compliant with MIL-HDBK-217

Block F/R = 3.23762 fpmh
 3237.62 fits

Block MTBF = 308869. Hrs.

Block Component Total = 64

WilStress V3.31

WIL-HDBK-217F NOTICE 1 PART STRESS PREDICTION

Standard Report

Project Name : SO-GD10
 Block : 5 Sensor Amplifier
 Description :
 Analyst :
 Environment : GF
 Amb. Temperature : 30

Description	Part Number	Circuit Reference	No. Off	Block/Comp. Fail. Rate	Total Fail. Rate	% Contrib
Connection, Reflow Solder			200	.00014	.02760	.76
CHIP RESISTOR, 1-100kohm, 0805, 0.125W	201-903XXX.A	GENERAL RESISTOR,	24	.02051	.49215	13.59
CHIP RESISTOR, 100k-10Mohm, 0805, 0.125W	201-903XXX.B	GENERAL RESISTOR,	8	.02256	.18045	4.98
METAL-FILM, AXIAL, 0.4W, 1-100kohm	201-AX	GENERAL RESISTOR,	2	.03752	.07505	2.07
RESISTOR, AXIAL, MET.F., 100k-10Mohm, 0.4W	201-BX	GENERAL RESISTOR,	2	.04128	.08255	2.28
CER. CHIP CAP., 47nF, 50V, X7R, 0805,	210-903774.8	C78, 84, 89, 93, 94 etc.	9	.01784	.16052	4.43
CER. CHIP CAP., 47nF, 50V, X7R, 0805,	210-903774.8	C96,	1	.02839	.02839	.78
CER. CHIP CAP., 2.2nF, 50V, X7R, 0805,	210-904104.7	C152, C153,	2	.01939	.03878	1.07
CER. CHIP CAP., 6.8nF, 50V, X7R, 0805,	210-904105.4	C154, C155,	2	.01442	.02884	.80
CER. CHIP CAP., 12nF, 50V, X7R, 0805,	210-904107.0	C156, C158,	2	.01535	.03070	.85
CER. CHIP CAP., 330pF, 50V, NPO, 0805,	210-904110.4	C108, C109,	2	.00519	.01039	.29
CER. CHIP CAP., 680pF, 50V, X7R, 0805,	210-904113.8	C150, C151,	2	.00566	.01133	.31
CER. CHIP CAP., 1uF, 25V, Y5V, 1206,	210-904114.6	C106,	1	.02562	.02562	.71
CER. CHIP CAP., 680nF, 25V, 1210,	210-904116.1	C160, C161, C163, C164,	4	.02991	.11965	3.31
CER. CHIP CAP., 680nF, 25V, 1210,	210-904116.1	C162, C165,	2	.03643	.07286	2.01
TANTAL CHIP CAP., 4.7uF, 50V, SEIZE D,	213-904117.9	C166,	1	.06189	.06189	1.71
CAP. MET. POLYESTER, 33nF, 50V, RADIAL,	213-904159.1	C157, C159,	2	.07477	.14953	4.13
TRANS. MOS-FET, N-CH, 2N7002, SOT-23,	241-904005.6	Q1, Q2, Q17, Q18,	4	.33705	1.34820	37.24
LN. J-FET INPUT OP. AMP., TLO71D, SO-8,	244-903988.4	U22, U23,	2	.08086	.16171	4.47
LP. Op. AMPLIFIER, MC33174D, SO-14,	244-903990.0	U25, U26,	2	.14772	.29544	8.16
DIGITAL POTMETER, DUAL, DS1267SN, SO-16W	244-903991.8	U24,	1	.15571	.15571	4.30
CONNECTOR, 2x7 PIN,	370-804092.5	ST1,	1	.06129	.06129	1.69
RECONNECTION ASSEMBLY	INTAS		1	.00148	.00148	.04

* = component non-compliant with WIL-HDBK-217

Block F/R = 3.62011 fpmh
 3620.11 fits

Block MTBF = 276235. hrs.

Block Component Total = 76

WILStress V3.31

WIL-HDBK-217F NOTICE 1 PART STRESS PREDICTION

Standard Report

Project Name : SU-GD10
 Block : 1 Gasdetector GD10
 Description : Power & Processing Assembly
 Analyst : SA
 Environment : GF
 Amb. Temperature : 10

Description	Test Number	Circuit Reference	No. Of	Block/Comp.	Total		Contr
				Fail. Rate	Fail. Rate		
			1	1.73136	1.73136	16.21	
2 External Interface			1	3.87391	3.87391	36.27	
3 Powersupply			1	2.47021	2.47021	23.10	
4 CPU			1	2.60477	2.60477	24.39	
Sensor Amplifier							

* = component non-compliant with WIL-HDBK 217

Block F/R = 10.68025 fpmh
 10680.25 fits

Block MTBF = 93631. Hrs.

Block Component Total = 0

WilStress V3.31

WIL-HDBK-217F NOTICE 1 PART STRESS PREDICTION

Standard Report

Project Name : 50-GE10

Block : 4 External Interface
 Description :
 Analyst :
 Environment : GF
 Amb. Temperature : 10

Description	Part Number	Circuit Reference	No. Off	Block/Comp. Fail. Rate	Total Fail. Rate	W
Connection, Reflow Solder			126	.00014	.01739	1.00
CHIP RESISTOR, 1-100kOhm, 0805, 0.125W.	201-903XXX.A	GENERAL RESISTORS	22	.00958	.21652	12.18
CER. CHIP CAP., 47nF, 50V, X7R, 0805.	210-903774.8	C49	1	.09208	.09208	5.32
CER. CHIP CAP., 47nF, 50V, X7R, 0805.	210-903774.8	C5	1	.01696	.01696	.98
CER. CHIP CAP., 47nF, 50V, X7R, 0805.	210-903774.8	C50	1	.01636	.01636	.94
CER. CHIP CAP., 47nF, 50V, X7R, 0805.	210-904105.4	C15, C16,	2	.07444	.14688	8.60
CER. CHIP CAP., 6.6nF, 50V, X7R, 0805.	210-904110.4	C107	1	.01443	.01443	.83
CER. CHIP CAP., 330pF, 50V, NPO, 0805.	210-904110.4	C8, C9, C10, C11,	4	.00208	.00831	.48
CER. CHIP CAP., 330pF, 50V, NPO, 0805.	210-904110.4	C100,	1	.02627	.02627	1.52
CER. CHIP CAP., 330nF, 25V, X7R, 1206.	210-904111.2	C100,	1	.02968	.02968	1.71
CER. CHIP CAP., 1uF, 25V, Y5V, 1206.	210-904114.6	C102,	1	.00204	.00204	.12*
TRANS., PNP, LF, BC856B, SOT-23,	241-903534.6	Q12,	1	.20827	.20827	12.03*
TRANS. MOS-FET, DUAL, N-CH, NDS9945, SO-8	241-903758.1	Q5,	1	.21793	.21793	12.59*
TRANS. MOS-FET, DUAL, N-CH, 2N7002, SOT-23,	241-904005.6	Q10,	1	.00677	.02031	1.17
DIODE, RECT., BYD17G, 400V, 1.5A, SOD87.	242-904006.4	D3, D13, D14,	3	.04593	.09185	5.31*
DIODE, TRANSORB-BIDIR, SM6T15CA, 33V, 600W	243-903999.1	D17, D18,	2	.04593	.09185	5.31*
DIODE, TRANSORB-BIDIR, SM6T33CA, 33V, 600W	243-904000.7	D19, D20,	2	.07547	.15094	8.72*
DIODE, ZENER, 12V, BZX84-C12, SOT-23,	243-904004.9	D4, D5,	1	.03176	.03176	1.83
PREC. QUAD. OP-AMP, TLE2024IDW, SO-16W.	244-903992.6	U11,	1	.07431	.07431	4.29
RS485 LINE TRANSCIEVER, ADM485JR, SO-8,	244-903997.5	U12,	1	.05311	.05311	3.07
PINHEADER, 2x4PIN, STRAIGHT,	370-903565.0	P3,	1	.07231	.07231	4.18
RIBBONE CABLE JUMPER, 13P,	380-904142.7	W1,	1	.03285	.03285	1.91
RIBBONE CABLE JUMPER, 2P,	380-904143.5	W2, W3, W4, W5,	4	.00410	.00410	.24
INTERCONNECTION ASSEMBLY	INTA2		1			

* = component non-compliant with WIL-HDBK-217

Block F/R = 1.73136 fph
 1731.26 fits

Block MTBF = 577580. Hrs.

Block Component Total = 54

MIL-STD-883C

MIL-HDBK-217F NOTICE 1 PART STRESS PREDICTION

Standard Report

Project Name : SO-6D10

Block : 5 Powersupply
 Description :
 Analyst :
 Environment :
 Amb. Temperature : 10

Description	Part Number	Circuit Reference	No. Off	Block/Comp. Fail. Rate	Total Fail. Rate	% Contrib
Connection, Reflow Solder			169	.00014	.02332	.60
CHIP RESISTOR, 1-100koha, 0805, 0.125W,	201-903XXX.A	GENERAL RESISTORS	22	.00958	.21062	5.44
CHIP RESISTOR, 1-100koha, 1206, 0.25W,	201-903XXX.C	GENERAL RESISTORS	4	.00958	.03833	.99
CHIP RESISTOR, 0.22oha, 5%, 1206, 0.25W,	201-904146.8	R14	1	.00958	.00958	.25
CER. CHIP CAP., 1nF, 50V, 0805,	210-903523.9	C116,C120,	2	.01691	.03381	.87
CER. CHIP CAP., 1nF, 50V, 0805,	210-903523.9	C119,	1	.03247	.03247	.84
CER. CHIP CAP., 1nF, 50V, 0805,	210-903523.9	C121,	1	.01111	.01111	.29
CER. CHIP CAP., 1nF, 50V, 0805,	210-903523.9	C7,	1	.06029	.06029	1.56
CER. CHIP CAP., 47nF, 50V, X7R, 0805,	210-903774.8	C1,C134,C140,C143,	4	.09208	.36831	9.51
CER. CHIP CAP., 47nF, 50V, X7R, 0805,	210-903774.8	C130,C135,C142,C110,	4	.01696	.06785	1.75
CER. CHIP CAP., 47nF, 50V, X7R, 0805,	210-903774.8	C131,C137,	2	.22414	.44827	11.57
CER. CHIP CAP., 47nF, 50V, X7R, 0805,	210-903774.8	C139,	1	.02700	.02700	.70
CER. CHIP CAP., 100pF, 50V, NPO, 0805,	210-904108.8	C4,C116,	2	.00140	.00279	.07
CER. CHIP CAP., 180pF, 50V, NPO, 0805,	210-904109.6	C112,	1	.00155	.00155	.04
CER. CHIP CAP., 470pF, 50V, NPO, 0805,	210-904112.0	C6,C111,	2	.00173	.00347	.09
CAP., ELYT., RAD., LONG-LIFE, 220uF, 50V	213-904008.0	C128,	1	.18355	.18355	4.74
CAP., ELYT., RAD., LONG-LIFE, 470uF, 35V	213-904009.8	C123,	1	.12306	.12306	3.18
CAP., ELYT., RAD., HI-REL., 470uF, 50V,	213-904010.6	C144,	1	.19442	.19442	5.02
CAP., ELYT., RAD., HI-REL., 1000uF, 25V,	213-904011.4	C145,	1	.11898	.11898	3.07
CAP., ELYT., RADIAL, 10uF, 63V,	213-904012.2	C114,	1	.07867	.07867	2.03
CAP., ELYT., RADIAL, 10uF, 63V,	213-904012.2	C124,C125,	2	.10254	.20507	5.29
CAP., ELYT., RADIAL, 10uF, 63V,	213-904012.2	C3,	1	.07757	.07757	2.00
CAP., ELYT., RAD., LONG-LIFE, 100uF, 63V	213-904013.0	C127,	1	.11998	.11998	3.10
CAP., ELYT., RAD., HI-REL, 220uF, 10V,	213-904158.3	C146,	1	.13712	.13712	3.54
CAP., ELYT, RAD., 100uF, 16V,	213-904160.9	C17,C115,	2	.13880	.27761	7.17
INDUCTOR, RADIAL, 100uH, 1A, 92moha,	220-903555.1	L1,	1	.03186	.03186	.82*
INDUCTOR, RADIAL, 47uH, 1.5A,	220-904139.3	L3,	1	.03186	.03186	.82*
INDUCTOR, RADIAL, 100uH, 660mA,	220-904140.1	L5,	1	.03186	.03186	.82*
CHIP INDUCTOR, 10uH, 550mA, 1812,	222-903517.1	L6,L8,	2	.03185	.06372	1.64*
TRANS., NPN, LF, BC846B, SOT-23,	241-902818.4	Q4,	1	.00235	.00235	.06*
TRANS., PNP, LF, BC856B, SOT-23,	241-963334.6	Q3,	1	.00136	.00136	.04*
TRANS. MOS-FET, N CH, BUK483-60A, SOT-223	241-904003.1	Q5,	1	.24980	.24980	6.45*
DIODE, HS SWITCHING, 1N4148, SOT-23,	242-903523.1	D2,	1	.00669	.00669	.17*
DIODE, RECT., BYV20, 500V, 1.25A, SOD87,	242-904006.4	D15,	1	.02641	.02641	.68

* = component non-compliant with MIL-HDBK-217

Continued on Next Page.

EilStress V3.31

MIL-HDBK-217F NOTICE 1 PART STRESS PREDICTION

Standard Report

Project Name : 50-GD10
 Block 3 ...continued

RECT. DIODE, SCHOTTKY, 100V, 1A, WBR51100	242-904007.2	CR1,	3	.01246	.03737	.96
RECT. DIODE, SCHOTTKY, 100V, 1A, WBR51100	242-904007.2	CR3,	1	.01092	.01992	.28
RECT. DIODE, SCHOTTKY, 100V, 1A, WBR51100	242-904007.2	CR4,	1	.00745	.00745	.19*
DIODE, TRANZORB-BIDIR, SW6T33CA, 33V, 600W	243-904000.7	D25,	1	.04593	.04593	1.19*
DIODE, ZENER, 12V, BZY84-C12, SOT-23,	243-904004.9	D1,	1	.07547	.07547	1.95*
DC-DC CONVERTER CONTROL, MC33063AD, SO-8,	244-903556.9	U14,	1	.08534	.08534	2.20
DC-DC CONVERTER CONTROL, MC33063AD, SO-8,	244-903556.9	U15,	1	.08376	.08376	2.15
POWER CONTROLLER, MIC38C43BW, SO-8,	244-903985.0	U13,	1	.07839	.07839	2.02
VOLT. REG., LM317L, SO-8,	244-903987.6	U16,	1	.07680	.07680	2.03
SW. VOLT. CONVERTER, LMC7661M, SO-8,	244-904161.7	U1,	1	.06707	.06707	1.73
INTERCONNECTION ASSEMBLY	INTA3		1	.00246	.00246	.06

* = component non-compliant with MIL-HDBK-217

Block F/R = 3.87391 fpmh
 3873.91 fits

Block MTBF = 258137. Hrs.

Block Component Total = 82

MIL-STD-883C

MIL-HDBK-217F NOTICE 1 PART STRESS PREDICTION

Standard Report

Project Name : 50-GD10

Block : 4 CPU
 Description :
 Analyst :
 Environment : GF
 Amb. Temperature : 10

Description	Part Number	Circuit Reference	No. Off	Block/Frmo. Fail. Rate	Total Fail. Rate	% Contrib
Connection, Reflow Solder			218	.00014	.03008	1.22
CHIP RESISTOR, 1-100kOhm 0805, 0.125W,	201-903XXX.A	GENERAL RESISTORS	31	.00958	.29706	12.03
CHIP THERMISTOR, WTC, 2.2kOhm, 1206,	204-904214.8	R150,	1	.00390	.10500	4.25
CHIP CAP., 47nF, 50V, X7R, 0805,	210-903774.8	C52,53,56,58,59 etc.	9	.01840	.16560	6.70
CHIP CAP., 47nF, 50V, NPO, 0805,	210-904106.2	C147,C148,	2	.00109	.00219	.09
CER. CHIP CAP., 330nF, 25V, X7R, 1206,	210-904111.2	C101,	1	.02334	.02334	.94
CER. CHIP CAP., 330nF, 25V, X7R, 1206,	210-904111.2	C2,C13,C14,	3	.02031	.06094	2.47
CER. CHIP CAP., 1uF, 25V, Y5V, 1206,	210-904111.5	C103,C104,	2	.02374	.04749	1.92
CER. CHIP CAP., 1uF, 25V, Y5V, 1206,	210-904114.6	C12,	1	.02968	.02968	1.20
CER. CHIP CAP., 100nF, 50V, X7R, 1206,	210-904115.3	C149,	1	.01843	.01843	.75
CER. CHIP CAP., 470nF, 50V, 1206,	210-904173.2	C105,	1	.28874	.28874	11.69
CHIP INDUCTOR, 10uH, 180mA, 1210,	222-904141.9	L16,L17,	2	.03186	.06372	2.58*
QUARTZ CRYSTAL, 4.0MHz, HC49/4H,	230-904149.2	X2,	1	.11266	.11266	4.56
DIODE, DUAL, HS SWITCHING, BAV99, SOT-23	242-903998.3	D28,D29,	2	.00669	.01339	.54*
8-BIT uCONTROLLER, 87C196, PLCC-68,	244-810872.2	U17,	1	.90990	.90990	36.83
LOW-DROP VOLT. REGULATOR, LP2951AC, SO-8	244-903986.8	U2,	1	.07461	.07461	3.02
uP SUPERVISORY MONITOR, MAX809L, SOT-23,	244-903994.2	U21,	1	.02751	.02751	1.11
HCMOS 74HC08, SO-14,	244-903995.9	U18,	1	.02712	.02712	1.10
SERIAL EEPROM, 128x8 BIT, 24C01, SO-8,	244-903996.7	U19,	1	.14565	.14565	5.90*
LED, DUAL, GREEN-RED, SOT-23	245-903567.6	D27,	1	.00368	.00368	.15
SOCKET PLCC 68,	370-904148.4	D01,	1	.01768	.01768	.72
INTERCONNECTION ASSEMBLY	INTAM		1	.00574	.00574	.23

* = component non-compliant with MIL-HDBK-217

Block F/R = 2.47021 fpmh
 2470.21 fms

Block MTBF = 404824. Hrs.

Block Component Total = 64

VilStress V3.31

MIL-HDBK-217F NOTICE 1 PART STRESS PREDICTION

Standard Report

Project Name : SO-GD10
 Block : 5 Sensor Amplifier
 Description :
 Analyst :
 Environment : GF
 Amb. Temperature : 10

Description	Part Number	Circuit Reference	Qty. Off	Block/Comp. Fail. Rate	Total Fail. Rate	% Contrib
Connection, Reflow Solder			200	.00014	.02760	1.06
CHIP RESISTOR, 1-100kohm, 0805, 0.125W	201-903XXX.A	GENERAL RESISTOR,	24	.00958	.22999	8.83
CHIP RESISTOR, 100k-10Mohm, 0805, 0.125W	201-903XXX.B	GENERAL RESISTOR,	8	.01054	.08433	3.24
RES. METAL-FILM, AXIAL, 0.4W, 1-100kohm,	201-AX	GENERAL RESISTOR,	2	.03034	.06068	2.33
RESISTOR, AXIAL, MET.F., 100k-10Mohm, 0.4W	201-BX	GENERAL RESISTOR,	2	.03337	.06675	2.56
CER. CHIP CAP., 47nF, 50V, X7R, 0805,	210-903774.8	C78,84,89,93,94 etc.	9	.01696	.15265	5.86
CER. CHIP CAP., 47nF, 50V, X7R, 0805,	210-903774.8	C96,	1	.02700	.02700	1.04
CER. CHIP CAP., 2.2nF, 50V, X7R, 0805,	210-904104.7	C152,C153,	2	.01844	.03688	1.42
CER. CHIP CAP., 6.8nF, 50V, X7R, 0805,	210-904105.4	C154,C155,	2	.01371	.02742	1.05
CER. CHIP CAP., 12nF, 50V, X7R, 0805,	210-904107.0	C156,C158,	2	.01460	.02919	1.12
CER. CHIP CAP., 330pF, 50V, NPO, 0805,	210-904110.4	C108,C109,	2	.00253	.00506	.19
CER. CHIP CAP., 680pF, 50V, X7R, 0805,	210-904113.8	C150,C151,	2	.00276	.00552	.21
CER. CHIP CAP., 1uF, 25V, Y5V, 1206,	210-904114.6	C106,	1	.02436	.02436	.94
CER. CHIP CAP., 680nF, 25V, 1210,	210-904116.1	C160,C161,C163,C164,	4	.02845	.11378	4.37
CER. CHIP CAP., 680nF, 25V, 1210,	210-904116.1	C162,C165,	2	.03464	.06929	2.66
TANTAL CHIP CAP., 4.7uF, 50V, SEIZE D,	213-904117.9	C166,	1	.04743	.04743	1.82
CAP. MET. POLYESTER, 33nF, 50V, RADIAL,	244-904159.1	C157,C159,	2	.06848	.13696	5.26
TRANS.MOS-FET, N-CH, 2N7002, SOT-23,	244-903988.4	Q1,Q2,Q17,Q18,	4	.21793	.87171	33.47
LH. J-FET INPUT OP.AMP., TL071D, SO-8,	244-903990.0	U22,U23,	2	.06500	.13000	4.99
DIGITAL POTMETER, W33174D, SO-14,	244-903991.8	U25,U26,	2	.13326	.26652	10.23
CONNECTOR, 2x7 PIN,	370-804092.5	U24,	1	.15232	.15232	5.81
INTERCONNECTOR ASSEMBLY	INTAS	ST1,	1	.03785	.03785	1.45
				.00148	.00148	.06

* = component non-compliant with MIL-HDBK-217

Block F/R = 2.60477 Fps
 2604.77 Fps

Block WTDF = 363911 Hrs.

Block Component Total = 76

.5,6,66H

MilStress - Error and Non-compliance Log

Block : 2 Part No. : 241-903534.6 Cct. Ref.: Q12,
Warning Junction Temp. NOT compliant with MIL-HDBK-217. [25 - 175]

Block : 2 Part No. : 241-904005.6 Cct. Ref.: Q10,
Warning Junction Temp. NOT compliant with MIL-HDBK-217. [25 - 175]

Block : 2 Part No. : 243-903999.1 Cct. Ref.: D17,D18,
Warning Junction Temp. NOT compliant with MIL-HDBK-217. [25 - 175]

Block : 2 Part No. : 243-904000.7 Cct. Ref.: D19,D20,
Warning Junction Temp. NOT compliant with MIL-HDBK-217. [25 - 175]

Block : 2 Part No. : 241-903758.1 Cct. Ref.: Q5,
Warning Junction Temp. NOT compliant with MIL-HDBK-217. [25 - 175]

Block : 2 Part No. : 243-904004.9 Cct. Ref.: D4,D5,
Warning Junction Temp. NOT compliant with MIL-HDBK-217. [25 - 175]

Block : 3 Part No. : 241-903534.6 Cct. Ref.: Q3,
Warning Junction Temp. NOT compliant with MIL-HDBK-217. [25 - 175]

Block : 3 Part No. : 241-902818.4 Cct. Ref.: Q4,
Warning Junction Temp. NOT compliant with MIL-HDBK-217. [25 - 175]

Block : 3 Part No. : 241-904003.1 Cct. Ref.: Q6,
Warning Junction Temp. NOT compliant with MIL-HDBK-217. [25 - 175]

Block : 3 Part No. : 243-904004.9 Cct. Ref.: D1,
Warning Junction Temp. NOT compliant with MIL-HDBK-217. [25 - 175]

Block : 3 Part No. : 242-904007.2 Cct. Ref.: CR4,
Warning Junction Temp. NOT compliant with MIL-HDBK-217. [25 - 175]

Block : 3 Part No. : 242-903536.1 Cct. Ref.: D2,
Warning Junction Temp. NOT compliant with MIL-HDBK-217. [25 - 175]

Block : 3 Part No. : 243-904000.7 Cct. Ref.: D25,
Warning Junction Temp. NOT compliant with MIL-HDBK-217. [25 - 175]

Block : 3 Part No. : 220-903555.1 Cct. Ref.: L1,
Warning Hot Spot Temp. NOT compliant with MIL-HDBK-217 [Range: 30 - 150]

Block : 3 Part No. : 220-904139.3 Cct. Ref.: L3,
Warning Hot Spot Temp. NOT compliant with MIL-HDBK-217 [Range: 30 - 150]

Block : 3 Part No. : 220-904140.1 Cct. Ref.: L5,
Warning Hot Spot Temp. NOT compliant with MIL-HDBK-217 [Range: 30 - 150]

Block : 3 Part No. : 222-902517.1 Cct. Ref.: L6,L8,
Warning Hot Spot Temp. NOT compliant with MIL-HDBK-217 [Range: 30 - 150]

Block : 4 Part No. : 244-903996.7 Cct. Ref.: U19,
Warning Junction Temp. NOT compliant with MIL-HDBK-217. [25 - 175]

Block : 4 Part No. : 242-903998.3 Cct. Ref.: D28,D29,
Warning Junction Temp. NOT compliant with MIL-HDBK-217. [25 - 175]

Block : 4 Part No. : 222-904141.9 Cct. Ref.: L16,L17,
Warning Hot Spot Temp. NOT compliant with MIL-HDBK-217 [Range: 30 - 150]

Block : 5 Part No. : 241-904005.6 Cct. Ref.: Q1,Q2,Q17,Q18,
Warning Junction Temp. NOT compliant with MIL-HDBK-217. [25 - 175]

Appendix B:

- | | |
|-------------------------------------|------------------------|
| 1) Reference list GD10 | SDM-60304 |
| 2) ISO Certificate Simrad-Optronics | Certificate no: 900612 |
| 3) ISO Certificate Simtronics | Certificate no: 900612 |
| 4) Nemko01Atex163Q | 806-813913 |
| 5) Nemko01Atex282 | 806-813901 |
| 6) Nemko00Atex138x | 806-813231 |
| 7) SIRA certificate: SIRAEX9748025 | 806-811450 |

Reference List GD10P, GD10PE and GD10L

General

Status March 2007

The GD10 family of gas detectors has been in production since 1996, with minor incremental updates only. The GD10 comes in 3 basic versions:

GD10P: Point detector

GD10PE: Extended point detector (from 2003)

GD10L: Line of sight (from 2001)

More than 45 000 GD10 gas detectors has been manufactured so far.

Please note that the references listed below are an extract, showing the distribution on clients, countries and application.

GD10P - Point

Client	Project	Country	Year	Qty
Amoco	Valhall	Norway	1997	105
Elf	Girazzol	Angola	1998	38
Statoil	Kårstø Petrochemical plant	Norway	1998	366
Shell	Shearwater	UK	1998	86
Norsk Hydro	Oseberg	Norway	1998	159
Woodside	North Rankin A	Australia	1998	213
Esso	Kingfish A	Australia	1999	60
Norsk Hydro	Snorre B	Norway	1999	138
Saga	Snorre B	Norway	1999	210
Single Buoy Moorings	FPSO Kuito	Angola	1999	127
Single Buoy Moorings	FPSO Espadarte	Brazil	1999	144
Texaco	Captain B	UK	1999	112
M/D Totco	Mudlogging on drillrig	USA	98-00	170
Formosa Plastics	Point Comfort, Chemical plant	USA	2000	37
Total marine	North Alwyn A/B	UK	2000	495
Wintershall	L8P4	Netherlands	2000	56
Technip	LDPE Petlin, Chemical	Malaysia	2000	89
Marathon Oil	Brae A/B	UK	2001	505
Norsk Hydro	Grane	Norway	2001	264
How Fire Ltd.	Lef Balal (turbines)	Iran	2001	17
Lamprell	Abu Dhabi	UAE	2001	11
Bord Gais Eireann	Gormanston AGI, Process Piping	Ireland	2002	33
Conoco Canada Corporation	Edson, Alberta Gas Plant	Canada	2002	10
Santa Fe	Rig 183 & 184	USA	2002	88
Single Buoy Moorings	FPSO Brasil, Eage and Atlantic		2002	481
Statoil	LNG Hammerfest (Snøhvit)	Norway	2003	320
Statoil	Statfjord A/B/C	Norway	2003	300
Azerbaijan Int. Oil Company		Azerbaijan	2003	85
BP	Texas City Plant	USA	2003	47
Husky Energy	White Rose Offshore FPSO	Canada	2003	150
Azerbaijan Int. Oil Company	Shah Deniz, Phase II	Azerbaijan	2004	114
Conoco Phillips	2/4M	Norway	2004	100
Exxon Mobil	Ache Refinery (upgrade)	Indonesia	2004	76



Reference: SDM-60304 - Reference list GD10
Author: @dill@simsky

Reference List GD10P, GD10PE and GD10L

Client	Project	Country	Year	Qty
Single Buoy Moorings	FPSO		2005	101
Marathon Oil Norway	FPSO Alvheim	Norway	2005	60
BP	Mike Mike	Indonesia	2006	51
DUGAS	Margham	Dubai	2006	247
Quenos	Platform	Australia	2006	110
Petronas	Duyong	Malaysia	2006	57
BP	West Lobe	Indonesia	2006	73
	Refinery	Hong Kong	2007	85

GD10PE –Extended Point

Client	Project	Country	Year	Qty
DUGAS	Platform (Gas turbine)	Dubai	2004	7
AIOC	Shaz Deniz (HVAC)	Azerbaijan	2004	15
Borealis Polymers OY	Chemical (Ethylene)	Finland	2004	30
EnCana	Buzzard (Gas turbine)	UK	2004	18
Wintershall	F16A (Gas turbine)	Netherlands	2004	6
BP	Mike Mike	Indonesia	2006	13
Shell	FPSO Bonga	UK	2006	46
ANT	Gas Turbines	USA	2006	45
Siemens	Bedford Dolphin	Norway	2007	39

GD10L – Open Path

Client	Project	Country	Year	Qty
STAREX	FPSO	Nigeria	2004	5
Premier Oil	West Lobe	Indonesia	2005	12
Single Buoy Moorings	FPSO Capixaba	Brasil	2005	26
BP	Tanggung	Indonesia	2005	41
DUGAS	Margham	Dubai	2006	31



S E R T I F I K A T

Det bekreftes herved at

Simrad Optronics ASA

oppfyller kravene til kvalitetsstyringssystemer angitt i

NS-EN ISO 9001:2000

og Nemko Certifications bestemmelser for sertifisering

Sertifikatet gjelder følgende virksomhetsområder:

Utvikling, produksjon, salg og markedsføring
av elektro-optiske instrumenter til militære og sivile markeder

Oslo, den 19. februar 2004

A handwritten signature in blue ink that reads 'Kirsten Svindahl'.

Kirsten Svindahl
Adm. direktør
Nemko Certification AS

Gyldig til: 2007-02-19
Første gang utstedt: 2004-02-19
Sertifikat nr: 900612





C E R T I F I C A T E

www.nemko.com

Simtronics ASA Oslo, Norway

has implemented and maintains a Quality Management System
which fulfills Nemko's provisions for Management System Certification and
the requirements of the following standard

NS-EN ISO 9001:2000

The certificate covers the following activities:

Development, Production, sales & marketing
of electro optical instruments and systems for the industrial market

Oslo, 2007-02-15

Claus Breyholtz
Nemko AS, Certification Department



Certificate number: 900612
First time issued: 2004-02-19
Expires: 2010-02-19



Worldwide Testing and Certification

[1] PRODUCT QUALITY ASSURANCE NOTIFICATION

**[2] Equipment or Protected System Intended for use
in Potentially explosive atmospheres
Directive 94/9/EC**

- [3] Notification Number :** Nemko 01ATEX163Q
- [4] Equipment or Protective System
or Components as listed:** Gasdetectors GD10-series
⊕ II 2 G EEX de
- [5] Applicant and Manufacturer:** Simrad Optronics ASA
[6] P. O. Box 6114 Etterstad
N-0602 Oslo
NORWAY
- [7] Nemko AS, notified body number 0470 for Annex VII in accordance with Article 9 of Council Directive 94/9/EC of 23 March 1994 notifies to the applicant that the actual manufacturer has a product quality system which complies to Annex VII of the Directive.**
- [8] This notification is based on audit report No 20686 issued the 2004-04-01 and 2004-09-06**
- The notification can be withdrawn if the manufacturer no longer satisfies the requirements of Annex VII.**
- Results of periodical re-assessment of the quality system are a part of this notification.**
- [9] This notification is valid until 2007-10-31 and can be withdrawn if the Manufacturer does not satisfy the production quality assurance re-assessment.**
- [10] According to Article 10[1] of the Directive 94/9/EC the CE marking shall be followed by the identification Number 0470 identifying the notified body involved in the product control stage.**

This certificate may only be reproduced in its entirety and without any change (including up dates).

2004-09-06

Asv 
Bernt J. Orderud
Head of section for Production Surveillance

806-813913 Rev.1

Nemko AS is an independent testing and certification laboratory offering services world wide from our offices/subsidiaries in Norway, UK, Germany, Italy, USA and Taiwan.

Postal address:
P.O.Box 73 Blindern
N-0314 OSLO, NORWAY

Office address:
Gaustadalléen 30
0371 OSLO

Telephone:
+47 22 96 03 30
Fax:
+47 22 96 05 50

Enterprise number:
NO 974404532



[1] EC-TYPE EXAMINATION CERTIFICATE

[2] Equipment or Protected System Intended for use
in Potentially explosive atmospheres
Directive 94/9/EC

- [3] EC-Type Examination Certificate Number: Ncmko 01ATEX282
- [4] Equipment or Protective System: Gas Detector
- [5] Applicant / Manufacturer: Simrad Optronics ASA
- [6] Address: Postbox 6114
0602 Oslo
Norway
- [7] This equipment or protective system and any acceptable variation thereto is specified in the schedule to this certificate and the documents therein referred to.
- [8] Nemko AS, notified body number 0470 in accordance with Article 9 of Council Directive 94/9/EC of 23 March 1994, certifies that this equipment or protective system has been found to comply with the Essential Health and Safety requirements relating to the design and construction of equipment and protective systems intended for use in potentially explosive atmospheres given in Annex II to the Directive.
- The examination and test results are recorded in confidential report no. 200111144
- [9] Compliance with the Essential Health and Safety Requirements has been assured by compliance with:
CENELEC EN 50014: 1997 + A1: 1999 + A2: 1999, CENELEC EN 50018 : 2000, CENELEC EN 50019 : 2000
IEC 60079-0: 2000, IEC 60079-1: 2001 and IEC 60079-7: 1990 + A1: 1991 + A2: 1993
- [10] If the sign "X" is placed after the certificate number, it indicates that the equipment or protective system is subject to special conditions for safe use specified in the schedule to this certificate.
- [11] This EC-TYPE EXAMINATION CERTIFICATE relates only to the design, examination and tests of the specified equipment or protective system in accordance to the directive 94/9/EC.
Further requirements of the Directive apply to the manufacturing process and supply of this equipment or protective system. These are not covered by this certificate.
- [12] The marking of the equipment or protective system shall include the following :



II 2 G

EEx de IIC T6

Oslo, 2001-09-10

Rolf Hoel
Certification Manager

Tore Irjall
Project Engineer

806-813901

REV. 3

This certificate may only be reproduced in its entirety and without any change, schedule included.

Postal address:
P.O.Box 73 Blindern
N-0314 OSLO, NORWAY

Office address:
Gaustadalléen 30
0373 OSLO

Telephone:
+47 22 96 03 30
Fax:
+47 22 96 05 50

Enterprise number:
NO 974404532



Nemko 01ATEX282

Date: 2001-09-10



Page 2 of 2

[13] Schedule

[14] EC-TYPE EXAMINATION CERTIFICATE No Nemko 01ATEX282

[15] Description of Equipment or Protective System

This Certificate covers a gas detector with type designation GD10P. It is a point detector for gas concentration monitoring in potentially hazardous and/or poisonous environments.

Type Designation

GD10P

Technical Data

18 to 32V DC, 3,5W

Ingress Protection Code

IP66/67 according to EN 60529.

[16] Report No. 200111144

Composed in total 37 pages and 10 pages of descriptive documents

Descriptive Documents

Name/Title	Drawing No.	Rev.	Date	Sheets
Housing Machined Gas Detector GD10P	599-809465.8	4	01.06.27	1
Optical unit Machined Gas Detector GD10P	599-809488.0	5	01.06.28	1
Cover terminal Moulded Gas Detector GD10P	599-810524.9	1	00.09.19	1
Optical unit Subassydrawing Gas Detector GD10P	770-810849.0	4	01.06.28	1
Optical unit Subassydrawing Gas Detector GD10P	770-810849.0	3	01.02.15	1
Housing Assembly Drawing Gas Detector GD10P	770-810850.8	3	01.06.28	1
Ring Machined Gas Detector GD 100 MKH	400-803938.0	1	01.02.15	1
Lens(plano convex) Gas Detector GD100 MKH	410-803197.3	2	01.02.15	1
Mirror Gas Detector GD10P	412-811261.7	1	01.02.15	1
Plate, Ident Gas Detector GD10P	Nemko	A	01.09.07	1

[17] Special conditions for safe use

None

[18] Essential Health and Safety Requirements

See item 9

The measuring function according to Annex II paragraph 1.5.5 of the Directive is not matter of this EC-type examination.

This certificate may only be reproduced in its entirety and without any change, schedule included.

Postal address:
P.O.Box 73 Blindern
N-0314 OSLO, NORWAY

Office address:
Gaustadalléen 30
0373 OSLO

Telephone:
+47 22 96 03 30
Fax:
+47 22 96 05 50

Enterprise number:
NO 974404532



Nemko 01ATEX282



Page 1 of 1

SUPPLEMENT 1 TO EC-TYPE EXAMINATION CERTIFICATE

[13] Schedule

[14] EC-TYPE EXAMINATION CERTIFICATE No **Nemko 01ATEX282**

[15] Description of Equipment or Protective System

This Certificate is extended to include the following:

Gas detector with Optical Unit machined out of acid resistant bolt.

The modifications are included in the descriptive documents.

Type Designation

GD10PE

[16] Report No.: 200231302

Composed in total 2 pages

Descriptive Documents

Name/Title	Drawing No.	Rev.	Date	Sheets
OPTICAL UNIT FLANGE S Machined Gas Detector GD10PE	599-813813.3	0	01.10.12	1 of 1
OPTICAL UNIT Subassembly Drawing Gas Detector GD10PE	770-813844.8	0	02.05.02	1 of 1
OPTICAL UNIT FLANGE L Machined Gas Detector GD10PE	599-813642.6	0	01.10.12	1 of 1
OPTICAL UNIT Subassembly Drawing Gas Detector GD10PE	770-813843.0	0	02.04.29	1 of 1

The Descriptive Documents mentioned above are amendments to *OPTICAL UNIT, Machined, Gas Detector GD10P, Drwg. No. 599.809488.0* and *OPTICAL UNIT, Subassembly Drawing, Gas Detector GD10P, Drwg. No. 770-810849.0*, upon which the EC-Type Examination Certificate Number Nemko 01ATEX282 is based.

Oslo 2002-08-08

Rolf Hoel
Certification Manager

Asgeir Holt
Project Engineer

This certificate may only be reproduced in its entirety and without any change, schedule included.

Postal address:
P.O.Box 73 Blindern
N-0314 OSLO, NORWAY

Office address:
Gaustadalléen 30
0373 OSLO

Telephone:
+47 22 96 03 30
Fax:
+47 22 96 05 50

Enterprise number:
NO 974404532



Nemko 01ATEX282



Page 1 of 2

SUPPLEMENT 2 TO EC-TYPE EXAMINATION CERTIFICATE

[14] EC-TYPE EXAMINATION CERTIFICATE No Nemko 01ATEX282

[15] Description of Equipment or Protective System

This Certificate is extended to include the following:

GD10P: Extension of the range of ambient temperature in service: $-40^{\circ}\text{C} \leq T_a \leq 65^{\circ}\text{C}$. Temp. Class: T6
 Range of ambient temperature in service for optical path unit: $-40^{\circ}\text{C} \leq T_a \leq 85^{\circ}\text{C}$. Temp. Class: T5
 Electrical Performance Temperature: $T_a -20^{\circ}\text{C}$ to $+40^{\circ}\text{C}$ alt. $T_a -20^{\circ}\text{C}$ to $+60^{\circ}\text{C}$

GD10PE: Extension of the range of ambient temperature in service: $-40^{\circ}\text{C} \leq T_a \leq 65^{\circ}\text{C}$ Temp. Class: T6
 Range of ambient temperature in service for optical path unit: $-40^{\circ}\text{C} \leq T_a \leq 85^{\circ}\text{C}$. Temp. Class: T5
 Electrical Performance Temperature: $T_a -20^{\circ}\text{C}$ to $+40^{\circ}\text{C}$

GD10PE-H: Extension of GD 10PE, but with a heating element for the mirror.
 Range of ambient temperature in service: $-40^{\circ}\text{C} \leq T_a \leq 65^{\circ}\text{C}$. Temp. Class: T6
 Range of ambient temperature in service for optical path unit: $-40^{\circ}\text{C} \leq T_a \leq 85^{\circ}\text{C}$. Temp. Class: T5
 Electrical Performance Temperature: $T_a -20^{\circ}\text{C}$ to $+60^{\circ}\text{C}$

[16] Report No. 11029

Descriptive Documents

Name/Title	Drawing No.	Rev.	Date	Sheets
HOUSING Machined Gas Detector GD10P	599-809465.8	7	03.02.19	1
OPTICAL UNIT Machined Gas Detector GD10P	599-809488.0	6	02.05.07	1
HOUSING Assembly Drawing Gas Detector GD10P	770-810850.8	6	02.04.14	1
LENS (PLANO CONVEX) Gas Detector GD100 MKII	410-803197.3	3	02.07.30	1
FAMILY TREE Gas Detector GD10PE	831-814264.8	0	03.11.07	1
FAMILY TREE Gas Detector GD10PE-H	831-814242.4	0	03.11.07	1
HEAT ELEMENT Gas Detector GD10PE-H	379-814197.0	0	03.11.07	1
TUBE, HEAT TRACING Gas Detector GD10PE-H	599-814196.2	0	03.11.07	1
RING RETAINER Machined GD10PE	571-814193.9	0	03.11.07	1
PLATE, GUIDING Machined Gas Detector GD10PE	599-814216.8	0	03.11.07	1
COVER PLATE Machined Gas Detector GD10PE	599-814215.0	0	03.11.07	1
SUPPORT MIRROR Machined Gas Detector GD10PE-H	599-814188.9	0	03.11.07	1
OPTICAL UNIT Machined Gas Detector GD10PE-H	599-814177.2	0	03.11.07	1
OPTICAL UNIT FLANGE Machined Gas Detector GD10PE	599-814260.6	0	03.11.07	1
OPTICAL UNIT Assembly Drawing Gas Detector GD10PE-H	770-814179.8	0	03.11.07	2
OPTICAL UNIT Subassembly Gas Detector GD10PE-H	770-814178.0	0	03.11.07	1
DETECTOR Assembly Gas Detector GD10PE-H	770-814242.4	0	03.11.07	1
COVER Assembly drawing Gas Detector GD10P	770-810869.8	1	00.09.19	1

Routine Test

Routine testing not required due to compliance of static pressure testing four times the reference pressure

This certificate may only be reproduced in its entirety and without any change, schedule included.

Postal address:
 P.O.Box 73 Blindern
 N-0314 OSLO, NORWAY

Office address:
 Gaustadalléen 30
 0373 OSLO

Telephone:
 +47 22 96 03 30
 Fax:
 +47 22 96 05 50

Enterprise number:
 NO 974404532



Nemko 01ATEX282



Page 1 of 1

SUPPLEMENT 3 TO EC-TYPE EXAMINATION CERTIFICATE

[14] EC-TYPE EXAMINATION CERTIFICATE No Nemko 01ATEX282

[15] Description of Equipment or Protective System

This Certificate is extended to include minor changes of the design and revision of descriptive documents.

Type Designation

GD10P, GD10PE and GD10PE-H

[16] Report No. 58364

Descriptive Documents

Name/Title	Drawing No.	Rev.	Date	Sheets
OPTICAL UNIT Machined Gas Detector GD10P	599-809488	8	05.10.26	1
HOUSING Assembly Drawing Gas Detector GD10P	770-810850	7	04.04.29	1
OPTICAL UNIT Subassembly Drawing Gas Detector GD10PE-H	770-814178	1	05.10.14	1
PLATE, GUIDING Machined Gas Detector GD10PE	599-814216	2	05.11.24	1
TUBE, HEAT TRACING Gas Detector GD10PE-H	599-814196	1	05.10.14	1
OPTICAL UNIT Machined Gas Detector GD10PE-H	599-814177	1	05.10.14	1
RING RETAINER Machined GD10PE	571-814193	2	05.11.24	1
PLATE, IDENT BLANK/ATEX Gas Detector GD10	590-813900	1	05.02.25	1
OPTICAL UNIT Subassydrawing Gas detector GD10P	770-810849	5	04.06.29	1

Routine Test

Routine testing not required due to compliance of static pressure testing four times the reference pressure

[17] Special Conditions for Safe Use

None

[18] Essential Health and Safety Requirements

EMC Directive 89/336/EEC, Article 4 is covered by Certificate no. 584 from Delta
Performance qualities for detection of Methane, Propane, Ethene and Propene are in conformity with BS EN 61779-1 and BS EN 61779-4. Ref. Report No. N 0457 issued by Sira Test & Certification, Chislehurst, UK.

Oslo, 2006-01-10

Rolf Hoel
Certification Department

This certificate may only be reproduced in its entirety and without any change, schedule included.

Postal address:
P.O.Box 73 Blindern
N-0314 OSLO, NORWAY

Office address:
Gaustadalléen 30
0373 OSLO

Telephone:
+47 22 96 03 30
Fax:
+47 22 96 05 50

Enterprise number:
NO 974404532



Nemko 01ATEX282



Page 1 of 1

SUPPLEMENT 4 TO EC-TYPE EXAMINATION CERTIFICATE

[14] EC-TYPE EXAMINATION CERTIFICATE No Nemko 01ATEX282

[15] **Description of Equipment or Protective System**

This Certificate is extended to include an integrated cemented bushing between the EEx d- and EEx e-enclosure.

Type Designation

GD10P, GD10PE and GD10PE-H

[16] **Report No. 74657**

Descriptive Documents

Name/Title	Drawing No.	Rev.	Date	Sheets
HOUSING Assembly Drawing Gas Detector GD10P	770-810850	9	2006-12-20	1
HOUSING Machined Gas Detector GD10P	599-809465	8	2006-10-26	1
HOUSING ASSY GD10P	499-810850	6	2006-10-26	1

Routine Test

Routine testing not required due to compliance of static pressure testing four times the reference pressure

[17] **Special Conditions for Safe Use**

None

[18] **Essential Health and Safety Requirements**

EMC Directive 89/336/EEC, Article 4 is covered by Certificate no. 584 from Delta
Performance qualities for detection of Methane, Propane, Ethene and Propene are in conformity with BS EN 61779-1 and BS EN 61779-4. Ref. Report No. N 0457 issued by Sira Test & Certification, Chislehurst, UK.

Oslo, 2007-01-31

Rolf Hoel
Certification Manager, Ex-products

This certificate may only be reproduced in its entirety and without any change, schedule included.

Postal address:
P.O.Box 73 Blindern
N-0314 OSLO, NORWAY

Office address:
Gaustadalléen 30
0373 OSLO

Telephone:
+47 22 96 03 30
Fax:
+47 22 96 05 50

Enterprise number:
NO 974404532



806-813231 REV. 3



Page 1 of 2

[1] EC-TYPE EXAMINATION CERTIFICATE
[2] Equipment or Protective System Intended for use
in Potentially explosive atmospheres
Directive 94/9/EC

- [3] **EC-Type Examination Certificate Number :** Nemko 00ATEX138 X
- [4] **Equipment or Protective System :** Gas Detector
- [5] **Applicant:** Simrad Optronics ASA
 [6] **Address :** Postbox 6114
 0602 Oslo
 Norway
- [5] **Manufacturer:** Simrad Optronics ASA
 [6] **Address:** Postbox 6114
 0602 Oslo
 Norway
- [7] This equipment or protective system and any acceptable variation thereto is specified in the schedule to this certificate and the documents therein referred to.
- [8] Nemko AS, notified body number 0470 in accordance with Article 9 of Council Directive 94/9/EC of 23 March 1994, certifies that this equipment or protective system has been found to comply with the Essential Health and Safety requirements relating to the design and construction of equipment and protective systems intended for use in potentially explosive atmospheres given in Annex II to the Directive.
- The examination and test results are recorded in confidential report no. : 200011223
- [9] Compliance with the Essential Health and Safety Requirements has been assured by compliance with:
- CENELEC EN 50014: 1997 + A1:1999,A2:1999
 CENELEC EN 50018: 1994
 CENELEC EN 50019: 1994
- [10] If the sign "X" is placed after the certificate number, it indicates that the equipment or protective system is subject to special conditions for safe use specified in the schedule to this certificate.
- [11] This EC-TYPE EXAMINATION CERTIFICATE relates only to the design and construction of the specified equipment or protected system. If applicable, further requirements of this Directive apply to the manufacturer and supply of this equipment or protective system.
- [12] The marking of the equipment or protective system shall include the following :

II 2 G

EEx de IIC T6

2000-10-02

for
 Rolf Hoel
 Head of section for Ex-equipment

Terje Johansen

This certificate may only be reproduced in its entirety and without any change, schedule included.

Postal address:
 P.O.Box 73 Blindern
 N-0314 OSLO, NORWAY

Office address:
 Gaustadalléen 30
 0373 OSLO

Telephone:
 +47 22 96 03 30
 Fax:
 +47 22 96 05 50

Enterprise number:
 NO 974404532



[13] Schedule

[14] EC-TYPE EXAMINATION CERTIFICATE No Nemko 00ATEX138 X

[15] Description of Equipment or protective system

GD 10 L is based on the point detector GD10. It's a combined transmitter/receiver with a separate reflector for detection of hydrocarbons.

Type Designation

GD10 L

Data

18 to 32 VDC
5W

IP 66/67 , according to CENELEC EN 60529

[16] Report No 200011223 consists of total 24 pages.

Descriptive Documents:

590-811961.2 Rev.:0 00.05.25
499-810850.8 Rev.:2 99.12.13
770-810850.8 Rev.:2 00.09.19
599-809465.8 Rev.:3 00.09.19
499-810869.8 Rev.:1 98.11.12
770-810869.8 Rev.:1 00.09.19
599-810524.9 Rev.:1 00.09.19
499-811965.3 Rev.:C5 00.09.19
770-811965.3 Rev.:0 00.09.22
410-811866.3 Rev.:0 00.09.21
599-811968.7 Rev.:0 00.09.21
599-811933.1 Rev.:0 00.09.21
770-811858.0 Rev.:0 00.09.22

[17] Special conditions for safe use

Must be placed in area where it is low risk of mechanical danger.

[18] Essential Health and Safety Requirements

See item 9

This certificate may only be reproduced in its entirety and without any change, schedule included.

Postal address:
P.O.Box 73 Blindern
N-0314 OSLO, NORWAY

Office address:
Gaustadalléen 30
0373 OSLO

Telephone:
+47 22 96 03 30
Fax:
+47 22 96 05 50

Enterprise number:
NO 974404532



Nemko 00ATEX138X



Page 1 of 1

SUPPLEMENT 1 TO EC-TYPE EXAMINATION CERTIFICATE

[14] EC-TYPE EXAMINATION CERTIFICATE No **Nemko 00ATEX138X**

[15] **Description of Equipment or Protective System**

This Certificate covers an extension of ambient temperature in service range to -40°C to 65°C. Due to the low temperature testing has been done according to final IEC 60079-1 draft (31A/114/FDIS)

Electrical Performance Temperature: Ta -20°C to + 45°C

[9] **Compliance with the Essential Health and Safety Requirements has been assured by compliance with:**

CENELEC EN 50014: 1997 + A1: 1999 + A2: 1999 (IEC 60079-0: 2000)
 CENELEC EN 50018: 2000 (IEC 60079-1: 2001 and draft 31A/114/FDIS)
 CENELEC EN 50019: 2000 (IEC 60079-7: 2001)

[16] **Report No. 14133**

Descriptive Documents

Name/Title	Drawing No.	Rev.	Date	Sheets
Plate , Ident Nemko Gas Detector GD10L	590-814915	C	04.04.27	1

Routine Test

Routine testing according to clause 16 in EN 50018 shall be carried out. The reference pressure is 8,6 bar.

[17] **Special Conditions for Safe Use**

Must be placed in a area where it is low risk of mechanical danger
 Performance testing for detection has not been carried out

[18] **Essential Health and Safety Requirements**

See item 9

Oslo, 2004-04-30

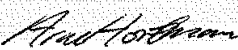
 Rolf Hoel
 Certification Department

This certificate may only be reproduced in its entirety and without any change, schedule included.

Postal address:
 P.O.Box 73 Blindern
 N-0314 OSLO, NORWAY

Office address:
 Gaustadalléen 30
 0373 OSLO

Telephone:
 +47 22 96 03 30
 Fax:
 +47 22 96 05 50

Enterprise number:
 NO 974404532



Nemko 00ATEX138X



Page 1 of 1

SUPPLEMENT 2 TO EC-TYPE EXAMINATION CERTIFICATE

[14] EC-TYPE EXAMINATION CERTIFICATE No Nemko 00ATEX138X

[15] **Description of Equipment or Protective System**

This Certificate is extended to include minor changes of the design and revision of descriptive documents.

Type Designation

GD10L

[16] **Report No. 58738**

Descriptive Documents

Name/Title	Drawing No.	Rev.	Date	Sheets
HOLDER FRONT LENS Assembly Drawing Gas Detector GD10L	770-811965.3	1	01.06.28	1
POWER & PROSSESING Assembly Drawing Gas Detector GD10L	770-911858.0	1	03.09.30	1
HOUSING Assembly Drawing Gas Detector GD10P	770-810850	7	04.04.29	1
HOLDER FRONT LENS Machined Gas Detector GD10L	599-811933	2	05.10.26	1
HOUSING MACH GD10P	599-809465.8	7	03.02.19	1
PLATE, IDENT Gas Detector GD10L	590-811961.2	1	02.10.22	1
HOLDER FRONT LENS ASSY GD10L	499-811965	1	01.06.28	1
HOUSING ASSY GD10P	499-810850	5	01.10.23	1

Routine Test

Routine testing according to clause 16 in EN 50018 shall be carried out. The reference pressure is 8,6 bar.

[17] **Special Conditions for Safe Use**

Must be placed in an area where it is low risk of mechanical danger

[18] **Essential Health and Safety Requirements**

See item 9

Oslo, 2006-01-18

Rolf Hoel
Certification Department

This certificate may only be reproduced in its entirety and without any change, schedule included.

Postal address:
P.O.Box 73 Blindern
N-0314 OSLO, NORWAY

Office address:
Gaustadalléen 30
0373 OSLO

Telephone:
+47 22 96 03 30
Fax:
+47 22 96 05 50

Enterprise number:
NO 974404532



Nemko 00ATEX138X



Page 1 of 1

SUPPLEMENT 3 TO EC-TYPE EXAMINATION CERTIFICATE

[14] EC-TYPE EXAMINATION CERTIFICATE No Nemko 00ATEX138X

[15] **Description of Equipment or Protective System**

This Certificate is extended to include an integrated cemented bushing between the EEx d- and EEx e-enclosure.

Type Designation

GD10L

[16] **Report No. 74657**

Descriptive Documents

Name/Title	Drawing No.	Rev.	Date	Sheets
HOUSING Assembly Drawing Gas Detector GD10P	770-810850	9	2006-12-20	1
HOUSING Machined Gas Detector GD10P	599-809465	8	2006-10-26	1
HOUSING ASSY GD10P	499-810850	6	2006-10-26	1

Routine Test

Routine testing according to clause 16 in EN 50018 shall be carried out. The reference pressure is 8,6 bar.

[17] **Special Conditions for Safe Use**

Must be placed in an area where it is low risk of mechanical danger

[18] **Essential Health and Safety Requirements**

See item 9

Oslo, 2007-01-31

Rolf Hoel

Certification Manager, Ex-products

This certificate may only be reproduced in its entirety and without any change, schedule included.

Postal address:
P.O.Box 73 Blindern
N-0314 OSLO, NORWAY

Office address:
Gaustadalléen 30
0373 OSLO

Telephone:
+47 22 96 03 30
Fax:
+47 22 96 05 50

Enterprise number:
NO 974404532

806-811450**REV. 1****GROUP II****1 PRODUCT CONFORMITY CERTIFICATE - PERFORMANCE**

2 SCS No: Ex 97Y8025

3 This Certificate is issued for the following gas detection and measurement apparatus:

GD10 and GD10C Infrared Gas Detector

4 Manufactured by:

Simrad Optronics A/S
 Ensjoveien 23b
 P.O. Box 6114 Etterstad
 N-0602 Oslo
 Norway

5 Submitted for certification by:

The Manufacturer.

6 This apparatus and any acceptable variation thereto is specified in the schedule to this Certificate and the documents therein referred to.

7 Sira Certification Service being accredited by the United Kingdom Accreditation Service through the NACB scheme certifies that the apparatus has been found to comply with the following performance standards:

BS EN 50054 : 1991 : Electrical apparatus for the detection and measurement of combustible gases
 General requirements and test methods
 BS EN 50057 : 1991 : Electrical apparatus for the detection and measurement of combustible gases
 Performance requirements for Group II apparatus indicating up to 100% LEL

and has successfully met the examination and test requirements which are recorded in a confidential
 ST&C Test Report No. N 0216

8 The supplier of the apparatus referred to in this Certificate has the responsibility to ensure that the apparatus conforms to the specification laid down in the Schedule to this Certificate and has satisfied the routine verifications and tests referred to therein.

The use of this apparatus will normally be the subject of National Legislation and/or Installation Codes.

Dated: 26 June 1997

File No : PS/1921/00

I D Knott
 Chief Executive

This certificate and its schedules should always be reproduced in its totality

Page 1 of 3 **Sira Certification Service**

South Hill, Chislehurst, Kent, BR7 5EH, England
 Tel: 0181 467 2636 Fax: 0181 295 1990

SCS is the certification service of Sira Test & Certification Ltd

SCHEDULE**PRODUCT CONFORMITY CERTIFICATE - PERFORMANCE**

SCS No: Ex 97Y8025

Dated: 26 June 1997

DESCRIPTION

The instrument is a fixed installation Group II Infrared gas detector designed for the detection and measurement of combustible gas. The instrument provides a 4 to 20 mA output proportional to gas concentration. Explosion protection is achieved by a combination of increased safety and flameproof concepts (see NEMKO Certificate of Conformity Ex 96D321).

In order to establish compliance with the general requirements of BS EN 50054 : 1991 and with the performance requirements of BS EN 50057 : 1991, tests were performed on single production samples of model GD10 (serial No. 960008) and GD10C (serial No. 960007) gas detectors.

DOCUMENTATION

Number	Sheet	Rev	Date	Description
Ex 96D321	1 of 1	-	16 Jan 97	Certificate of Conformity
Ex 96D321	1 of 1	-	16 Jan 97	Annex to Certificate of Conformity
P3351E	1 of 1	-	May 1996	Technical data sheet
590-810790.6	1 of 1	1	22 Apr 97	Identification Plate GD10 100% LEL CH ₄ 5s SOURCE
590-811192.4	1 of 1	0	21 Apr 97	Identification Plate GD10 100% LEL CH ₄ 5s SINK
590-811209.6	1 of 1	1	22 Apr 97	Identification Plate GD10 100% LEL CH ₄ 1s SOURCE
590-811343.3	1 of 1	1	22 Apr 97	Identification Plate GD10 100% LEL CH ₄ 1s SINK
590-810912.6	1 of 1	1	22 Apr 97	Identification Plate GD10C 100% LEL CH ₄ 5s SOURCE
590-811195.7	1 of 1	0	21 Apr 97	Identification Plate GD10C 100% LEL CH ₄ 5s SINK
590-811193.2	1 of 1	0	21 Apr 97	Identification Plate GD10C 100% LEL CH ₄ 1s SOURCE
590-811194.0	1 of 1	0	21 Apr 97	Identification Plate GD10C 100% LEL CH ₄ 1s SINK
P3359E	-	2nd edition	May 97	Operation & Instruction Manual

This certificate and its schedules should always be reproduced in its totality

Page 2 of 3 **Sira Certification Service**

South Hill, Chislehurst, Kent, BR7 5EH, England
Tel: 0181 467 2636 Fax: 0181 295 1990

SCS is the certification service of Sira Test & Certification Ltd

SCHEDULE



PRODUCT CONFORMITY CERTIFICATE - PERFORMANCE

SCS No: Ex 97Y8025

Dated: 26 June 1997

CONDITIONS OF CERTIFICATION

- 1 The use of the Sira Certification Service Mark is subject to the regulations applicable to the holders of SCS certificates.
- 2 This certificate relates only to the apparatus specified herein as executed in the samples supplied for evaluation.
- 3 In affixing the SCS certificate number to the apparatus the manufacturer attests on his own responsibility that the apparatus conforms to the documents listed herein.

If the marked apparatus is found not to comply Sira Certification Service should be notified immediately at their office at South Hill, Chislehurst, Kent BR7 5EH, England.

- 4 The apparatus and that part of the manufacturer's quality management system controlling the production of the apparatus covered by this certificate shall be subject to periodic surveillance by SCS in accordance with the regulations applicable to the holders of SCS certificates.

This certificate and its schedules should always be reproduced in its totality

Page 3 of 3

Sira Certification Service

South Hill, Chislehurst, Kent, BR7 5EH, England
Tel: 0181 467 2636 Fax: 0181 295 1990

SCS is the certification service of Sira Test & Certification Ltd

SCS/SF/033
January 1996

FMECA Worksheet

Company : Simtronics
 Item : GD10
 Revised on : 27.06.07

ID No.	Item/ Functional Identification	Failure Mode(s)	Failure Rate [per hour]	Failure Cause(s)	Failure Effect(s)	Failure Detection Method	Compensating Provisions (Safeguards)	Remarks/ Failure Rate Assessment
Microprocessor unit								
1	<p><i>Function:</i> Controls and calculates the gas concentration</p> <p><i>Type:</i></p> <p><i>Make:</i></p>	<p>Memory failure (DD – Dangerous Detected)</p> <p>Failure of voltage supply (SD – Safe Detected)</p> <p>CPU freeze (SD – Safe Detected)</p> <p>I/O read/write error (SD – Safe Detected)</p> <p>No or incorrect clock signal (SU – Safe Undetected)</p>	<p>Failure rates</p> <p>$\lambda_{DD} =$</p> <p>$\lambda_{SD} =$</p> <p>$\lambda_{SU} =$</p> <p>$\lambda_{SS} =$</p>	<p>Component failure in memory electronics</p> <p>Component failure in power supply</p> <p>Software failure, unstable voltage levels, or hardware failures</p> <p>Failure of one or more of the inputs/outputs</p> <p>Failure of quartz crystal</p>	<p>Wrong execution of program code</p> <p>Voltage output to zero</p> <p>System out of operation No program execution</p> <p>System out of operation</p> <p>There will be no effects until the pulse duration is too long and the source will burn out.</p>	<p>Watchdog supervises the execution of code</p> <p>External and internal supervision of voltage</p> <p>External and internal supervision of voltage</p> <p>Microprocessor will indicate failure of I/O</p>		<p>Remarks:</p> <p>Failure Rate Assessment (e,j):</p>

FMECA Worksheet

Company : Simtronics
 Item : GD10
 Revised on : 27.06.07

ID No.	Item/ Functional Identification	Failure Mode(s)	Failure Rate [per hour]	Failure Cause(s)	Failure Effect(s)	Failure Detection Method	Compensating Provisions (Safeguards)	Remarks/ Failure Rate Assessment
Watchdog								
2	<p><i>Function:</i> To check the execution of the main code. The watchdog is a hardware component which will be triggered in software sequences with certain time intervals. Upon failure of the code execution, the watchdog will reset the microcontroller.</p> <p><i>Type:</i></p> <p><i>Make:</i></p>	<p>Failure of the watchdog (SU – Safe Undetected)</p>	<p>$\lambda_{SU} =$</p> <p>$\lambda_{SD} =$</p> <p>$\lambda_{SS} =$</p>	<p>Component failure in the watchdog</p>	<p>The code is executed without watchdog</p>	<p>No method of detection</p>		<p>Remarks:</p> <p>Failure Rate Assessment (e,j):</p>

FMEA Worksheet

Company : Simrad Optronics
 Item : Transmitter Module
 Revised on : 06.09.05

ID No.	Item/ Functional Identification	Failure Mode(s)	Failure Rate [per hour]	Failure Cause(s)	Failure Effect(s)	Failure Detection Method	Compen-sating Provisions (Safeguards)	Remarks/ Failure Rate Assessment
Chopper Electronics								
3	Function: Electronics creating the pulses for the main and reference beam. Type: Make:	Loss of pulse generation, either at zero or a constant value. (SD – Safe Detected)	Failure rates $A_{DU} =$ $A_{DC} =$ $A_{SU} =$ $A_{SD} =$	Failure of transistor Failure of gate between the microprocessor and the source.	Loss of function, the output will go to zero.	Detected by microprocessor, output will go to zero		Remarks: Failure Rate Assessment (e.g.):

FMEA Worksheet

Company : Simrad Optronics
 Item : Transmitter Module
 Revised on : 06.09.05

ID No.	Item/ Functional Identification	Failure Mode(s)	Failure Rate [per hour]	Failure Cause(s)	Failure Effect(s)	Failure Detection Method	Compen-sating Provisions (Safeguards)	Remarks/ Failure Rate Assessment
Output Electronics								
4	Function: Provides output signals from the microprocessor Type Make:	Freeze of the output signal at a certain level >4mA (DU – Dangerous Undetected)	Failure rates $A_{DU} =$ $A_{DC} =$ $A_{SU} =$ $A_{SD} =$	Failure of the output transistor or one of the other components on the output card.	Wrong indication of gas concentration at a level between 0% and up to an alarm level.			Remarks: Failure Rate Assessment (e.g.):
		Freeze of the output signal out of range (SD – Safe Detected)		Failure of one of the components on the output card	Stop of function, output to zero.			
		Drive voltage failure in source output (DD – Dangerous Detected)		Failure in drive voltage	The output will not be able to show more voltage than a certain level, e.g. 5mA	Internal voltage supervision will detect the error.		
		Drive voltage failure in sink output (DU – Dangerous Undetected)		Failure in drive voltage	The output will not be able to show more voltage than a certain level, e.g. 5mA			

FMEA Worksheet

Company : Simrad Optronics
 Item : Transmitter Module
 Revised on : 06.09.05

ID No.	Item/ Functional Identification	Failure Mode(s)	Failure Rate [per hour]	Failure Cause(s)	Failure Effect(s)	Failure Detection Method	Compen-sating Provisions (Safeguards)	Remarks/ Failure Rate Assessment
Signal Electronics including Detector								
5	Function: Lead the signal from the detector to the microprocessor and A/D converting the signal. Type: Make:	No signal to the microprocessor (SD – Safe Detected) Distorted signal to the microprocessor (SD – Safe Detected)	Failure rates $\lambda_{DU} =$ $\lambda_{CO} =$ $\lambda_{SU} =$ $\lambda_{SD} =$	Failure of the detector Component failure in the signal electronics Failure of the detector (converting the IR light to electrical signal) Failure of A/D converter Failure of amplifier Signal noise Lock of the multiplexer (A/D converter)	Loss of signal to the microprocessor, loss of function of the system Range of the detector shifts from 4mA	Detected by the microcontroller, zero output.	None	Remarks: Failure Rate Assessment (e.j):

FMEA Worksheet

Company : Simrad Optronics
 Item : Transmitter Module
 Revised on : 06.09.05

ID No.	Item/ Functional Identification	Failure Mode(s)	Failure Rate [per hour]	Failure Cause(s)	Failure Effect(s)	Failure Detection Method	Compen-sating Provisions (Safeguards)	Remarks/ Failure Rate Assessment
Power Supply								
6	Function: Provide and control voltage supply to the system. Type: Make:	Wrong voltage from the voltage regulators. (SD – Safe Detected) No voltage from the voltage regulators. (SD – Safe Detected)	Failure rates $\lambda_{DU} =$ $\lambda_{CO} =$ $\lambda_{SU} =$ $\lambda_{SD} =$	Too low range on the voltage Too high voltage Signal noise Failure of components in the voltage supply	Distorted signal Loss of function of the system	Detection by the microcontroller which will set the output to zero. Internal supervision of voltage.		Remarks: Failure Rate Assessment (e.j):