



3M™ Simtronics™ DF-TV7-T

Multi-spectrum IR Flame Detector

Presentation

The MultiFlame DF-TV7-T is a multi-spectrum infrared flame detector using three wavelengths. The MultiFlame DF-TV7-T responds to hydrocarbon fires and is the right choice for operation in dirty environments or for detection of smoky fires.

The MultiFlame DF-TV7-T is designed to respond to unwanted hydrocarbon fires, whilst maintaining a high degree of false alarm immunity.

The device offers a wide range of output options, as standard and is certified for use in SIL 3 applications. The unit may be interfaced directly with a wide range of fire panels, controllers and PLC's etc.

The unit is fully configurable using a wireless hand-held terminal (TLU600) or optionally via HART (TM) giving true flexibility to the installer. Time delays, sensitivity and output configuration are all set up via the TLU; a hazardous area approved hand-held unit. Wireless testing of the optical and output circuits are also possible using the TLU for a guaranteed ease of maintenance.

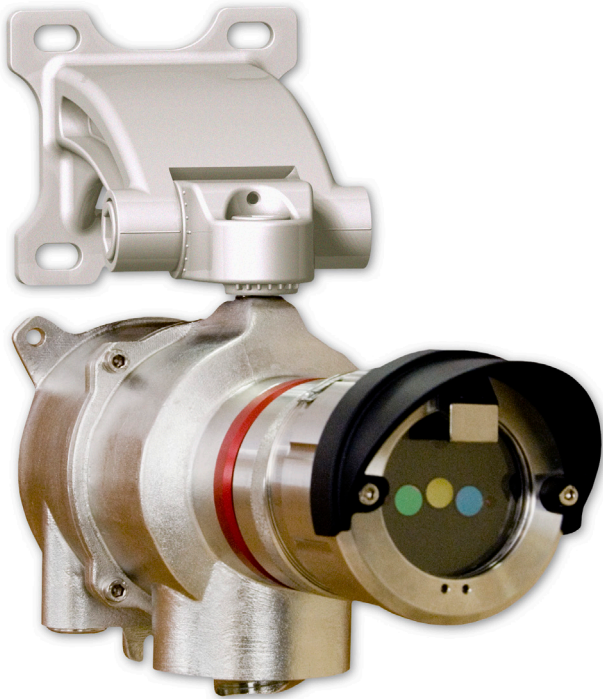

TLU Wireless (IR)
Hand-held Terminal

Characteristics

- Continuous auto-check of optical lens
- Relays, 4-20mA, 0-22mA, Hart outputs
- Long range up to 80m, 260 ft deep
- Wide field of view 120°

3M™ Simtronics™ DF-TV7-T

Multi-spectrum IR Flame Detector

Technical data

General

Technology	Technology Multi-spectrum Infrared, 3IR
Fire Types	Hydrocarbon fires
Range, n-heptane	80m (260ft) 0.3×0.3m (1 sq ft)
Range, gasoline	65m (210ft) 0.3×0.3m (1 sq ft)
Field of view	Maximum horizontal angle 120° Horizontal angle @ 50% 104° Vertical angle @ 50% 82°
Response time	adjustable from 3 to 20 seconds (typical 6s.)
Warranty	3 years, back to factory

Output signal

Standard	4-20mA or 0-22mA (configurable by the user) max. load impedance 700M (Std.) HART Protocol 7th edition (option) Lonworks for Syntel (option)
Alarms	2 x configurable Relays max 1 A / 30Vcc
Visual	Normal Operating, alarm, fault

Electrical

Power supply	24 Vdc, range (18 - 28 Vdc)
Power consumption	2W normal; 4W during test
Connection	0.3 mm ² (22 AWG) - 1.5 mm ² (16 AWG) Shielded cable recommended

Environmental

Storage:	-40°C to +70°C (-40°F to 158°F)
Operation	-40°C to +65°C (-40°F to 149°F)
Option	Sunshade, max. temp. 85°C (185°F)
Humidity	99% RH (non-condensing)
Ingress	IP66
RFI /EMI	Complies with EN50130-4

Explosion proof housing

TLU600	316 L STAINLESS STEEL
Weight	5KG (10 LBS)
Dimensions	246.8 × 140.4 × 115 mm (L, H, W) 9.8 × 5.5 × 4.5 inches

Approvals

SIL	SIL3 without redundancy according to IEC 61508-1 to 7
ATEX	II 2 G Ex d IIC T6 Gb (de -40°C à +65°C)
IECEX	IEC 60079-0 / IEC 60079-1
CE DPC	According to EN 54-10:2002 + A1:200

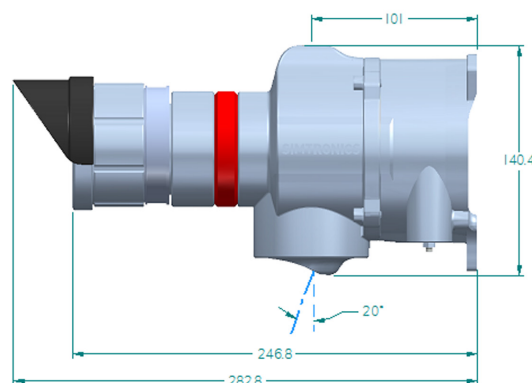
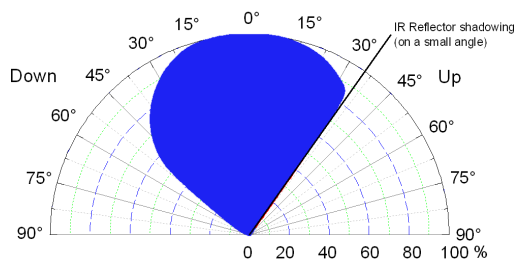
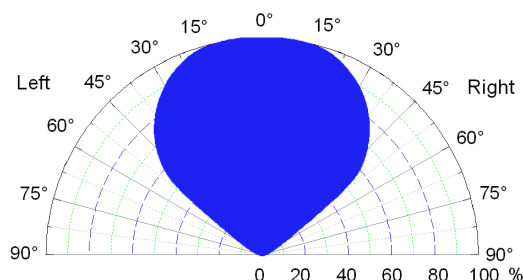

Accessories

TLU600	Infrared remote control unit, ATEX certified : II 1 G Ex ia IIC T4
LT15	Test lamp, ATEX certified : II 2 G Ex d IIC T6-T5
AS048-X	SS316 swivel bracket (with 2" or 2.5" pipe mounting)
AS056-450	Sun shade
AS040	Long type visor (vertical upper angle reduction)
AS041	Long type visor (horizontal and vertical angle reduction)
AS045	Air shield
AS215	Tag plate

Simtronics is a world-class provider of sophisticated gas and flame detection systems. The company has more than 25 years' experience in supplying gas detection for use in applications ranging from plant boiler rooms to offshore petrochemical facilities. Simtronics' products are used worldwide to help protect life and assets.

AMERICAS - Texas (USA)
4055 Technology Forest Blvd.
The Woodlands, TX 77381
Tel.: +1-800-247-7257
Fax: +1-281-292-2860

EMEA
ZI Est, Rue Orfila,
CS 20417
62027 ARRAS CEDEX, France
Tel.: +33-3-21-60-80-80
Fax: +33-3-21-60-80-00

ASIA PACIFIC
290 Guiqiao Road
Pudong, Shanghai 201206
People's Republic of China
Tel.: +86-21-3127-6373
Fax: +86-21-3127-6365



Copyright © 2018 3M, 3M Gas & Flame Detection. All rights reserved.
gasdetection.3m.com. GF-30080E-EN