

FC-3RLY2 LIMIT ALARM MODULE

HARDWARE USER MANUAL



Manual Number: FC-3RLY2-USER-M

⚡ WARNING ⚡

Thank you for purchasing automation equipment from **Automationdirect.com**[®], doing business as, **AutomationDirect**. We want your new automation equipment to operate safely. Anyone who installs or uses this equipment should read this publication (and any other relevant publications) before installing or operating the equipment.

To minimize the risk of potential safety problems, you should follow all applicable local and national codes that regulate the installation and operation of your equipment. These codes vary from area to area and usually change with time. It is your responsibility to determine which codes should be followed, and to verify that the equipment, installation, and operation is in compliance with the latest revision of these codes.

At a minimum, you should follow all applicable sections of the National Fire Code, National Electrical Code, and the codes of the National Electrical Manufacturer's Association (NEMA). There may be local regulatory or government offices that can also help determine which codes and standards are necessary for safe installation and operation.

Equipment damage or serious injury to personnel can result from the failure to follow all applicable codes and standards. We do not guarantee the products described in this publication are suitable for your particular application, nor do we assume any responsibility for your product design, installation, or operation.

Our products are not fault-tolerant and are not designed, manufactured or intended for use or resale as on-line control equipment in hazardous environments requiring fail-safe performance, such as in the operation of nuclear facilities, aircraft navigation or communication systems, air traffic control, direct life support machines, or weapons systems, in which the failure of the product could lead directly to death, personal injury, or severe physical or environmental damage ("High Risk Activities"). **AutomationDirect** specifically disclaims any expressed or implied warranty of fitness for High Risk Activities.

For additional warranty and safety information, see the Terms and Conditions section of our catalog. If you have any questions concerning the installation or operation of this equipment, or if you need additional information, please call us at 770-844-4200.

This publication is based on information that was available at the time it was printed. At **AutomationDirect** we constantly strive to improve our products and services, so we reserve the right to make changes to the products and/or publications at any time without notice and without any obligation. This publication may also discuss features that may not be available in certain revisions of the product.

Trademarks

This publication may contain references to products produced and/or offered by other companies. The product and company names may be trademarked and are the sole property of their respective owners. **AutomationDirect** disclaims any proprietary interest in the marks and names of others.

Copyright 2015, **Automationdirect.com**[®] Incorporated
All Rights Reserved

No part of this manual shall be copied, reproduced, or transmitted in any way without the prior, written consent of **Automationdirect.com**[®] Incorporated. **AutomationDirect** retains the exclusive rights to all information included in this document.

⚡ ADVERTENCIA ⚡

Gracias por comprar equipo de automatización de **Automationdirect.com**[®]. Deseamos que su nuevo equipo de automatización opere de manera segura. Cualquier persona que instale o use este equipo debe leer esta publicación (y cualquier otra publicación pertinente) antes de instalar u operar el equipo.

Para reducir al mínimo el riesgo debido a problemas de seguridad, debe seguir todos los códigos de seguridad locales o nacionales aplicables que regulan la instalación y operación de su equipo. Estos códigos varían de área en área y usualmente cambian con el tiempo. Es su responsabilidad determinar cuales códigos deben ser seguidos y verificar que el equipo, instalación y operación estén en cumplimiento con la revisión mas reciente de estos códigos.

Como mínimo, debe seguir las secciones aplicables del Código Nacional de Incendio, Código Nacional Eléctrico, y los códigos de (NEMA) la Asociación Nacional de Fabricantes Eléctricos de USA. Puede haber oficinas de normas locales o del gobierno que pueden ayudar a determinar cuales códigos y normas son necesarios para una instalación y operación segura.

Si no se siguen todos los códigos y normas aplicables, puede resultar en daños al equipo o lesiones serias a personas. No garantizamos los productos descritos en esta publicación para ser adecuados para su aplicación en particular, ni asumimos ninguna responsabilidad por el diseño de su producto, la instalación u operación.

Nuestros productos no son tolerantes a fallas y no han sido diseñados, fabricados o intencionados para uso o reventa como equipo de control en línea en ambientes peligrosos que requieren una ejecución sin fallas, tales como operación en instalaciones nucleares, sistemas de navegación aérea, o de comunicación, control de tráfico aéreo, máquinas de soporte de vida o sistemas de armamentos en las cuales la falla del producto puede resultar directamente en muerte, heridas personales, o daños físicos o ambientales severos (“Actividades de Alto Riesgo”). **Automationdirect.com** específicamente rechaza cualquier garantía ya sea expresada o implicada para actividades de alto riesgo.

Para información adicional acerca de garantía e información de seguridad, vea la sección de Términos y Condiciones de nuestro catálogo. Si tiene alguna pregunta sobre instalación u operación de este equipo, o si necesita información adicional, por favor llámenos al número 770-844-4200 en Estados Unidos.

Esta publicación está basada en la información disponible al momento de impresión. En **Automationdirect.com** nos esforzamos constantemente para mejorar nuestros productos y servicios, así que nos reservamos el derecho de hacer cambios al producto y/o a las publicaciones en cualquier momento sin notificación y sin ninguna obligación. Esta publicación también puede discutir características que no estén disponibles en ciertas revisiones del producto.

Marcas Registradas

Esta publicación puede contener referencias a productos producidos y/u ofrecidos por otras compañías. Los nombres de las compañías y productos pueden tener marcas registradas y son propiedad única de sus respectivos dueños. **Automationdirect.com**, renuncia cualquier interés propietario en las marcas y nombres de otros.

PROPIEDAD LITERARIA 2015, AUTOMATIONDIRECT.COM[®] INCORPORATED

Todos los derechos reservados

No se permite copiar, reproducir, o transmitir de ninguna forma ninguna parte de este manual sin previo consentimiento por escrito de **Automationdirect.com[®] Incorporated**. **Automationdirect.com** retiene los derechos exclusivos a toda la información incluida en este documento. Los usuarios de este equipo pueden copiar este documento solamente para instalar, configurar y mantener el equipo correspondiente. También las instituciones de enseñanza pueden usar este manual para propósitos educativos.

⚡ AVERTISSEMENT ⚡

Nous vous remercions d'avoir acheté l'équipement d'automatisation de **AutomationDirect.com**[®], en faisant des affaires comme, **AutomationDirect**. Nous tenons à ce que votre nouvel équipement d'automatisation fonctionne en toute sécurité. Toute personne qui installe ou utilise cet équipement doit lire la présente publication (et toutes les autres publications pertinentes) avant de l'installer ou de l'utiliser.

Afin de réduire au minimum le risque d'éventuels problèmes de sécurité, vous devez respecter tous les codes locaux et nationaux applicables régissant l'installation et le fonctionnement de votre équipement. Ces codes diffèrent d'une région à l'autre et, habituellement, évoluent au fil du temps. Il vous incombe de déterminer les codes à respecter et de vous assurer que l'équipement, l'installation et le fonctionnement sont conformes aux exigences de la version la plus récente de ces codes.

Vous devez, à tout le moins, respecter toutes les sections applicables du Code national de prévention des incendies, du Code national de l'électricité et des codes de la National Electrical Manufacturer's Association (NEMA). Des organismes de réglementation ou des services gouvernementaux locaux peuvent également vous aider à déterminer les codes ainsi que les normes à respecter pour assurer une installation et un fonctionnement sûrs.

L'omission de respecter la totalité des codes et des normes applicables peut entraîner des dommages à l'équipement ou causer de graves blessures au personnel. Nous ne garantissons pas que les produits décrits dans cette publication conviennent à votre application particulière et nous n'assumons aucune responsabilité à l'égard de la conception, de l'installation ou du fonctionnement de votre produit.

Nos produits ne sont pas insensibles aux défaillances et ne sont ni conçus ni fabriqués pour l'utilisation ou la revente en tant qu'équipement de commande en ligne dans des environnements dangereux nécessitant une sécurité absolue, par exemple, l'exploitation d'installations nucléaires, les systèmes de navigation aérienne ou de communication, le contrôle de la circulation aérienne, les équipements de survie ou les systèmes d'armes, pour lesquels la défaillance du produit peut provoquer la mort, des blessures corporelles ou de graves dommages matériels ou environnementaux («activités à risque élevé»). La société **AutomationDirect** nie toute garantie expresse ou implicite d'aptitude à l'emploi en ce qui a trait aux activités à risque élevé.

Pour des renseignements additionnels touchant la garantie et la sécurité, veuillez consulter la section Modalités et conditions de notre documentation. Si vous avez des questions au sujet de l'installation ou du fonctionnement de cet équipement, ou encore si vous avez besoin de renseignements supplémentaires, n'hésitez pas à nous téléphoner au 770-844-4200.

Cette publication s'appuie sur l'information qui était disponible au moment de l'impression. À la société **AutomationDirect**, nous nous efforçons constamment d'améliorer nos produits et services. C'est pourquoi nous nous réservons le droit d'apporter des modifications aux produits ou aux publications en tout temps, sans préavis ni quelque obligation que ce soit. La présente publication peut aussi porter sur des caractéristiques susceptibles de ne pas être offertes dans certaines versions révisées du produit.

Marques de commerce

La présente publication peut contenir des références à des produits fabriqués ou offerts par d'autres entreprises. Les désignations des produits et des entreprises peuvent être des marques de commerce et appartiennent exclusivement à leurs propriétaires respectifs. **AutomationDirect** nie tout intérêt dans les autres marques et désignations.

Copyright 2015, **AutomationDirect.com**[®] Incorporated
Tous droits réservés

Nulle partie de ce manuel ne doit être copiée, reproduite ou transmise de quelque façon que ce soit sans le consentement préalable écrit de la société **AutomationDirect.com**[®] Incorporated. **AutomationDirect** conserve les droits exclusifs à l'égard de tous les renseignements contenus dans le présent document.

FC-3RLY2 Limit Alarm Module Hardware User Manual



Please include the Manual Number and the Manual Issue, both shown below, when communicating with Technical Support regarding this publication.

Manual Number: FC-3RLY2-USER-M
Issue: 1st Edition
Issue Date: 04/16

Publication History		
Issue	Date	Description of Changes
1st Edition	04/16	Original Issue

TABLE OF CONTENTS



Chapter 1: Getting Started

Introduction	1-2
The Purpose of this Manual	1-2
Supplemental Manuals	1-2
Technical Support	1-2
Conventions Used	1-3
Key Topics for Each Chapter	1-3
Product Overview	1-4
Specifications	1-4
Status Indicators	1-6
DIP Switch Settings	1-6
Factory Settings	1-7

Chapter 2: Configuration and Programming

Input Signal Ranges	2-2
Modes of Operation	2-2
Independent and Simultaneous Relay Control Modes	2-2
Relay Trip Point / Release Point Control Modes	2-4
Normal (Non-failsafe) Mode [DIP Switch 6 OFF]	2-4
Failsafe Mode [DIP Switch 6 ON]	2-6
Non-Latching and Latching Relay Control Modes	2-8
Non-Latching Relay Control Mode [DIP Switch 8 OFF]	2-8
Latching Relay Control Mode [DIP Switch 8 ON]	2-8
Custom Trip Point Programming with Factory Release Point Dead-band	2-9
Programming Worksheet	2-9

Table of Contents

Programming Flowchart: Custom Trip Points with Factory Release Points Dead-band	2-10
Independent Relay Control [DIP Switch 7 OFF]	2-10
Simultaneous Relay Control [DIP Switch 7 ON]	2-11
Custom Trip Point Programming with Custom Release Points	2-12
Programming Worksheet.....	2-12
Programming Flowchart: Custom Trip Points with Custom Release Points.....	2-13
Independent Relay Control [DIP Switch 7 OFF]	2-13
Simultaneous Relay Control [DIP Switch 7 ON]	2-14

GETTING STARTED



In This Chapter...

Introduction	1-2
The Purpose of this Manual.....	1-2
Supplemental Manuals.....	1-2
Technical Support.....	1-2
Conventions Used	1-3
Key Topics for Each Chapter.....	1-3
Product Overview	1-4
Specifications.....	1-4
Status Indicators.....	1-6
DIP Switch Settings.....	1-6
Factory Settings.....	1-7

Introduction

1

The Purpose of this Manual

Thank you for purchasing the **FC-3RLY2 Analog Input, 2-Relay, Limit Alarm** module. This manual describes AutomationDirect.com's FC-3RLY2 modules, their specifications, and provides you with important information for installation, connectivity and setup. This manual shows how to install, wire and use the product.

This user manual contains important information for personnel who will install the Limit Alarm modules, and for the personnel who will be programming them. This information will provide all the information you need to get and keep these modules up and running.

Supplemental Manuals

If you are familiar with industrial control type devices, you may be able to get up and running with just the aide of the Product Guide included with each Limit Alarm module.

Technical Support

We strive to make our manuals the best in the industry. We rely on your feedback to let us know if we are reaching our goal. If you cannot find the solution to your particular application, or, if for any reason you need technical assistance, please call us at:

770-844-4200

Our technical support group will work with you to answer your questions. They are available Monday through Friday from 9:00 A.M. to 6:00 P.M. Eastern Time. We also encourage you to visit our web site where you can find technical and non-technical information about our products and our company.

<http://www.automationdirect.com>

Conventions Used



When you see the “notepad” icon in the left-hand margin, the paragraph to its immediate right will be a special note. The word **NOTE**: in boldface will mark the beginning of the text.



When you see the “exclamation mark” icon in the left-hand margin, the paragraph to its immediate right will be a warning. This information could prevent injury, loss of property, or even death (in extreme cases). The word **Warning**: in boldface will mark the beginning of the text.

Key Topics for Each Chapter

The beginning of each chapter will list the key topics that can be found in that chapter.

Getting Started	
	CHAPTER 1
In This Chapter...	
General Information	1-2
Specifications	1-4

Product Overview

1

This is an Analog to Relay Limit Alarm module that is field configurable for a variety of alarm and control applications. The FC-3RLY2 can be powered by 24VAC or 24VDC and accept input signals of 0-15V, 0- 30V, or 0-20mA. Configuration and Trip/Release Point programming is accomplished with DIP Switches, and a single PGM-pushbutton. LED's provide an indication of operating status and are used during the Trip/Release Point programming. The module can be DIN rail or side mounted.

Specifications

Input Specifications	
Number of Inputs and Type	1, Single Ended (1 common)
Input Ranges	0-15VDC, 0-30VDC, 0-20mA, DIP Switch selectable
Input Impedance	100K Ω voltage input / 250 Ohms current input
External Power Required	24VAC or 24VDC @ 100mA \pm 10% *
Low-pass Filtering	-3dB at 100Hz, (-6dB per octave)
Set/Release Point Voltage Repeatability	0.05% of full scale voltage range (constant temperature)
Set/Release Point Current Repeatability	0.1% of full scale current range (constant temperature)

* In order to comply with UL508 Class 2 Standards the supplied power must be less than 26VDC and fused at a maximum of 3 amps.

Output Specifications	
Relay Contacts	2 SPDT, Form C
Contact Rating	250VAC @ 5A, 30VDC @ 5A (Resistive Load), 380VAC Max., 30VDC Max.
Relay Operation	DIP Switch selectable
Relay Trip Point Setting	Program mode enabled by pushbutton
Relay Release Point Setting	Program mode enabled by pushbutton
Minimum Relay Dead-band = Trip Point \pm Release Point	0-15 VDC range: 1.0% minimum dead-band (150mV); 0-30VDC range: 1.0% minimum dead-band (300mV); 0-20mA range: 3.0% minimum dead-band (600 μ A)

Specifications (continued)

Terminal Block Specifications	
Field Wiring	Removable Screw Type Terminal Blocks
Number of Terminal Blocks	2-Two Position (Dinkle: EC350V-02P) 2-Three Position (Dinkle: EC350V-03P)
Wire Range	28-14AWG Solid or Stranded Conductor
Wire Strip Length	1/4" (6-7mm)
Screw Torque	1.7 inch-pounds (0.19 Nm)
Surrounding Air Temperature	0 to 60°C (32 to 140°F), IEC 60068-2-14 (Test Nb, Thermal Shock)
Storage Temperature	-20 to 70°C (-4 to 158°F) IEC 60068-2-1 (Test Ab, Cold) IEC 60068-2-2 (Test Bb, Dry Heat) IEC 60068-2-14 (Test Na, Thermal Shock)
Humidity	5 to 95% (non-condensing) IEC 60068-2-30 (Test Db, Damp Heat)
Environmental Air	No corrosive gases permitted EN61131-2 (Pollution degree 1)
Vibration	MIL STD 810C 514.2 IEC 60068-2-6 (Test Fc)
Shock	MIL STD 810C 516.2 IEC 60068-2-27 (Test Ea)
Insulation Resistance	>10MΩ @ 500VDC
Noise Immunity	NEMA ICS3-304 IEC 61000-4-2 (ESD) Impulse 1000V @ 1μs pulse IEC 61000-4-4 (FTB) RFI, (145 MHz, 440 MHz 5W @ 15cm) IEC 61000-4-3 (RFI)
Weight	0.3 lbs
Isolation	1800VDC Power to Input 1800VDC Power to Output 1800VDC Input to Output Applied for 1 second (100% Tested)*
Agency Approvals	UL508*, File Number: E157382, CE

* In order to comply with UL508 Class 2 Standards the supplied power must be less than 26VDC and fused at a maximum of 3 amps.

Status Indicators

Mode (Green/Red):

- Green LED is ON when unit is powered.
- Red LED is ON when in Program Mode. This Red LED flashes when setting a custom release point.
- Flashing Red/Green indicates Trip/Release Point program error.

Trip Points A or B:

- Red LED is ON when a Trip Point is tripped.
- Red LED is ON when setting a Trip Point in Program Mode.
- Flashing Red when setting a Release Point in Program Mode.

DIP Switch Settings

Factory settings shown in bold.

DIP Switches	Switch Positions							
	1	2	3	4	5	6	7	8
Input Ranges								
0-30V	0	0			NA			
0-15V	0	1			NA			
0-20mA	1	1			NA			
Relay Functions								
Trip Point A INC			0		NA			
Trip Point A DEC			1		NA			
Trip Point B INC				0	NA			
Trip Point B DEC				1	NA			
Normal (Non-Failsafe) Mode					NA	0		
Fail Safe Mode					NA	1		
Independent Relay Control					NA		0	
Simultaneous Relay Control					NA		1	
Non-Latching Relays					NA			0
Latching Relays					NA			1

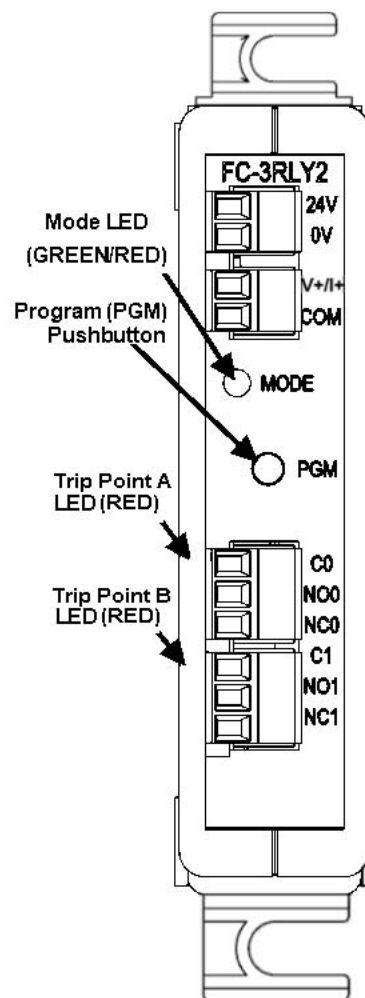

NOTE: A Power Cycle, entering programming mode, or a factory reset is required to read DIP Switch changes. All Trip Points MUST be programmed after any DIP Switch change.
NOTE: DIP Switch 4 is ignored in Simultaneous Relay Control mode.

Factory Settings

Factory Settings , INC Mode: Dead-band % calculated from full range

Range	Trip Point	Release Point (RP = TP - Deadband)	Dead-band
0-15VDC	7.5V	7.125V	2.5% (0.375V)
0-30VDC	15V	14.25V	2.5% (0.75V)
0-20mA	N/A*	N/A*	7.5% (1.5mA)

Factory Settings, DEC Mode: Dead-band % calculated from full range

Range	Trip Point	Release Point (RP = TP + Deadband)	Dead-band
0-15VDC	7.5V	7.875V	2.5% (0.375V)
0-30VDC	15V	15.75V	2.5% (0.75V)
0-20mA	N/A*	N/A*	7.5% (1.5mA)

* No factory settings for 0-20mA input range.

To Return to Factory Settings:

- Hold PGM pushbutton down for 10 seconds. Mode LED will turn RED and then will turn completely OFF.
- Release the PGM pushbutton. The Mode LED will turn GREEN. The unit has been successfully returned to Factory Settings values.
- Factory Reset does not function in Programming Mode.

CONFIGURATION AND PROGRAMMING



In This Chapter...

Input Signal Ranges	2-2
Modes of Operation	2-2
Independent and Simultaneous Relay Control Modes	2-2
Relay Trip Point / Release Point Control Modes	2-4
Normal (Non-failsafe) Mode [DIP Switch 6 OFF]	2-4
Failsafe Mode [DIP Switch 6 ON]	2-6
Non-Latching and Latching Relay Control Modes	2-8
Non-Latching Relay Control Mode [DIP Switch 8 OFF].....	2-8
Latching Relay Control Mode [DIP Switch 8 ON]	2-8
Custom Trip Point Programming with Factory Release Point Dead-band	2-9
Programming Worksheet.....	2-9
Programming Flowchart: Custom Trip Points with Factory Release Points Dead-band	2-10
Independent Relay Control [DIP Switch 7 OFF]	2-10
Simultaneous Relay Control [DIP Switch 7 ON].....	2-11
Custom Trip Point Programming with Custom Release Points	2-12
Programming Worksheet.....	2-12
Programming Flowchart: Custom Trip Points with Custom Release Points	2-13
Independent Relay Control [DIP Switch 7 OFF]	2-13
Simultaneous Relay Control [DIP Switch 7 ON].....	2-14

Input Signal Ranges

Input Ranges	DIP Switches							
	1	2	3	4	5	6	7	8
0-30V	0	0						
0-15V	0	1						
0-20mA	1	1						

Modes of Operation

Independent and Simultaneous Relay Control Modes

Independent Relay Control Mode [DIP Switch 7 OFF]

Relays A and B are controlled with independent Trip Points and Release Points for each relay. Relays A and B can be independently set to operate in Increasing or Decreasing mode (see next section). This mode can be used to control two loads in sequence, or monitor for multilevel alarm conditions.

Relay Control Mode	DIP Switches							
	1	2	3	4	5	6	7	8
Independent Relay Control							0	

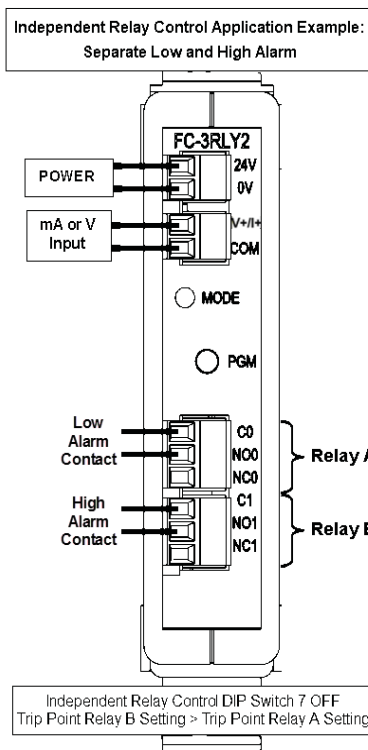

Simultaneous Relay Control Mode [DIP Switch 7 ON]

Relays A and B operate simultaneously, both controlled by Trip Point A and Release Point A settings. Both relays operate in Increasing or Decreasing mode (see next section) as set by Relay A DIP Switch 3. Relay B DIP Switch 4 is ignored in Simultaneous Relay Control Mode.

This mode can be used where it is desired to have both relays controlled by common Trip and Release points such as using one relay for local alarm indication with a horn or strobe and the other relay for remote alarm monitoring by a PLC.

Relay Control Mode	DIP Switches							
	1	2	3	4	5	6	7	8
Simultaneous Relay Control							1	

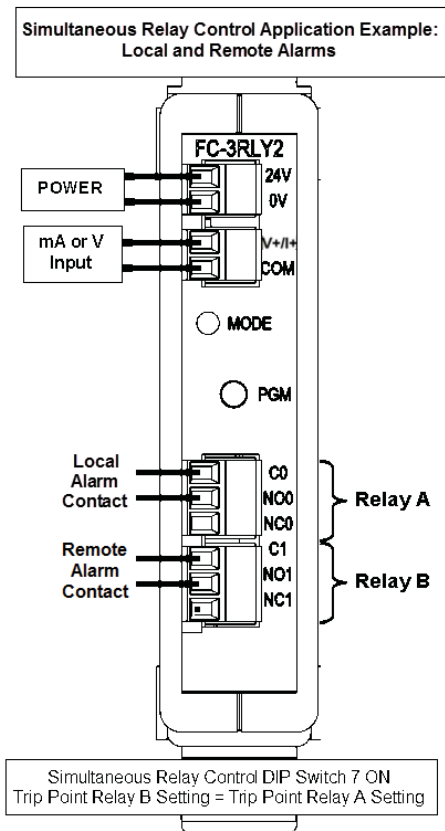

Relay Trip Point / Release Point Control Modes

Normal (Non-failsafe) Mode [DIP Switch 6 OFF]

Increasing (INC) Mode

[Relay A: DIP Switch 3 OFF; Relay B: DIP Switch 4 OFF]

The relay will turn ON when the input signal increases to the programmed Trip Point (TP). The relay will remain ON until the input signal decreases below the Release Point (RP). In INC mode, the Trip Point must always be greater than the Release Point ($TP > RP$).

NOTE: After programming the TP and RP for each relay, the FC-3RLY2 will verify that $TP > RP$. If $TP < RP$, the MODE LED will alternately flash green and red. If this occurs simply press and hold the PGM - pushbutton for 3 seconds until the MODE LED turns ON red and reprogram the TP and RP for that relay.

Relay Control Modes	DIP Switches							
Dip Switches	1	2	3	4	5	6	7	8
Trip Point A INC			0					
Trip Point B INC				0				
Normal (Non-failsafe) Mode						0		

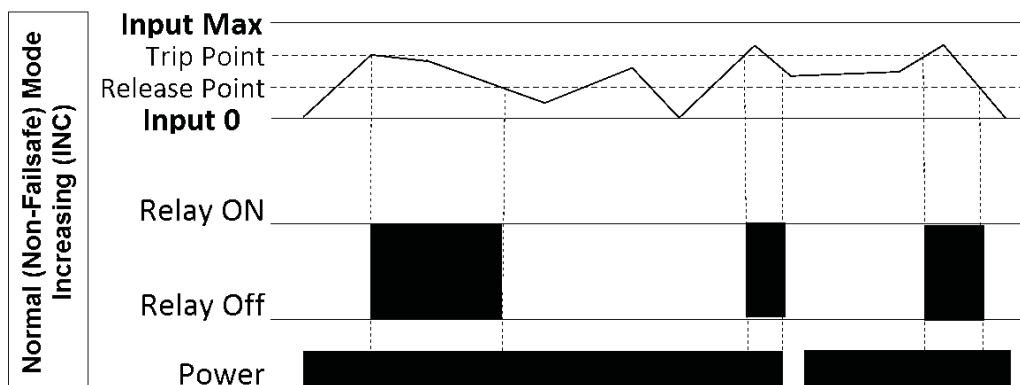

Decreasing (DEC) Mode

[Relay A: DIP Switch 3 ON; Relay B: DIP Switch 4 ON]

The relay will turn ON when the input signal decreases below the programmed Trip Point (TP). The relay will remain ON until the input signal increases above the Release Point (RP). In DEC mode, the Trip Point must always be less than the Release Point ($TP < RP$).

NOTE: After programming the TP and RP for each relay the FC-3RLY2 will verify that $TP < RP$. If $TP > RP$, the MODE LED will alternately flash green and red. If this occurs simply press and hold the PGM - pushbutton for 3 seconds until the MODE LED turns ON red and reprogram the TP and RP for that relay.

Relay Control Modes	DIP Switches							
Dip Switches	1	2	3	4	5	6	7	8
Trip Point A DEC			1					
Trip Point B DEC				1				
Normal (Non-failsafe) Mode						0		

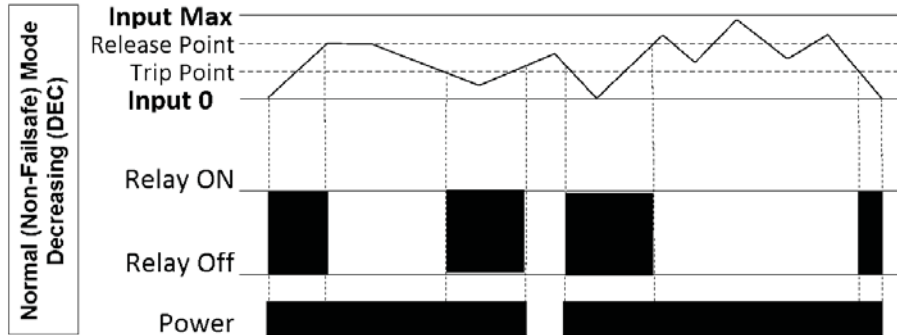

Application Examples

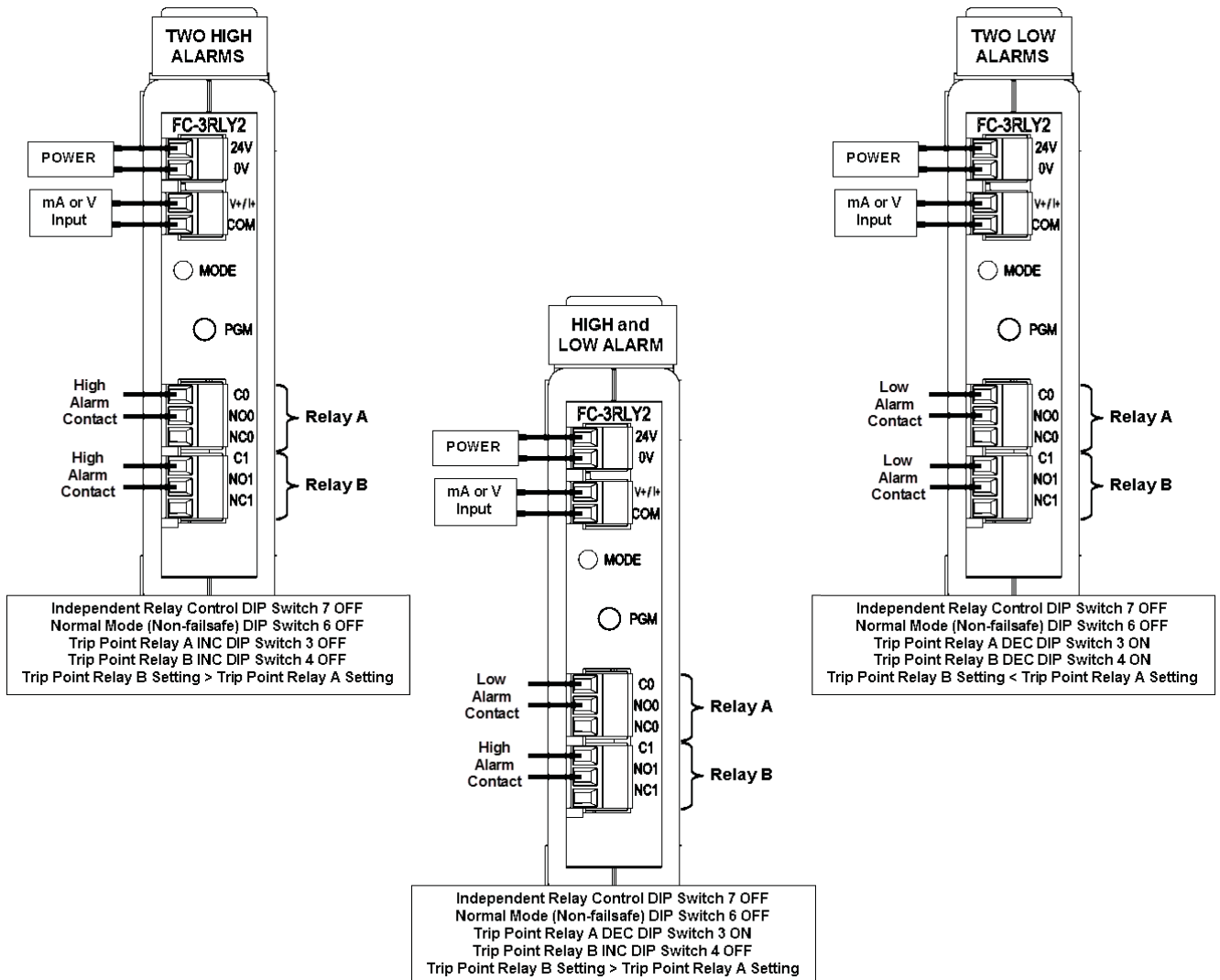

Failsafe Mode [DIP Switch 6 ON]

The relay action is reserved from Normal Mode.

NOTE: In Failsafe mode using the normally closed relay contacts for alarm conditions will also result in an alarm in the event of power loss to the FC-3RLY2 module.

Increasing (INC) Mode

[Relay A: DIP Switch 3 OFF; Relay B: DIP Switch 4 OFF]

The relay will turn OFF when the input signal increases to the programmed Trip Point. The relay will remain OFF until the input signal decreases below the Release Point. In INC mode, the Trip Point must always be greater than the Release Point ($TP > RP$).

NOTE: After programming the TP and RP for each relay the FC-3RLY2 will verify that $TP > RP$. If $TP < RP$, the MODE LED will alternately flash green and red. If this occurs simply press and hold the PGM - pushbutton for 3 seconds until the MODE LED turns ON red and reprogram the TP and RP for that relay.

Relay Control Mode	DIP Switches							
	1	2	3	4	5	6	7	8
Trip Point A INC	■	■	0	■	■	■	■	■
Trip Point B INC	■	■	■	0	■	■	■	■
Failsafe Mode	■	■	■	■	■	1	■	■
Independent Relay Control	■	■	■	■	■	■	0	■
Non-Latching Relay Control	■	■	■	■	■	■	■	0

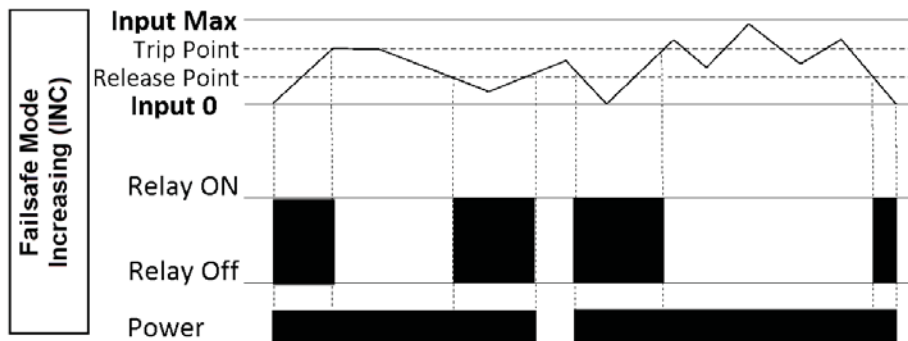

Decreasing (DEC) Mode

[Relay A: DIP Switch 3 ON; Relay B: DIP Switch 4 ON]

The relay will turn OFF when the input signal decreases below the programmed Trip Point. The relay will remain OFF until the input signal increases above the Release Point. In DEC mode, the Trip Point must always be less than the Release Point ($TP < RP$).

NOTE: After programming the TP and RP for each relay the FC-3RLY2 will verify that $TP < RP$. If $TP > RP$, the MODE LED will alternately flash green and red. If this occurs simply press and hold the PGM - pushbutton for 3 seconds until the MODE LED turns ON red and reprogram the TP and RP for that relay.

Relay Control Modes	DIP Switch Positions							
	1	2	3	4	5	6	7	8
Trip Point A DEC			1					
Trip Point B DEC				1				
Failsafe Mode						1		
Independent Relay Control							0	
Non-Latching Relay Control								0

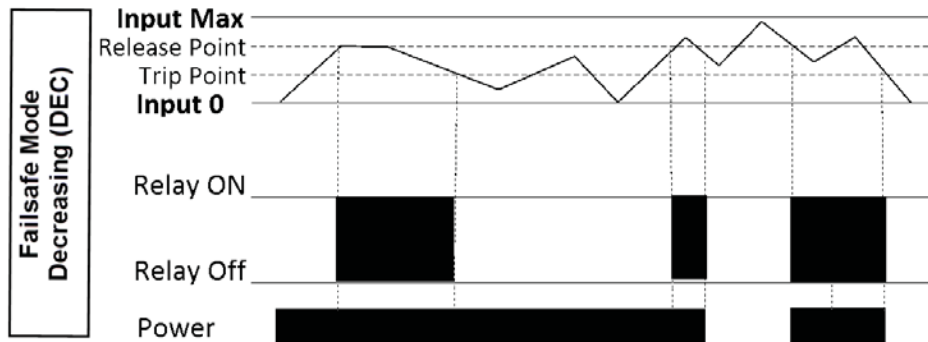

Application Examples

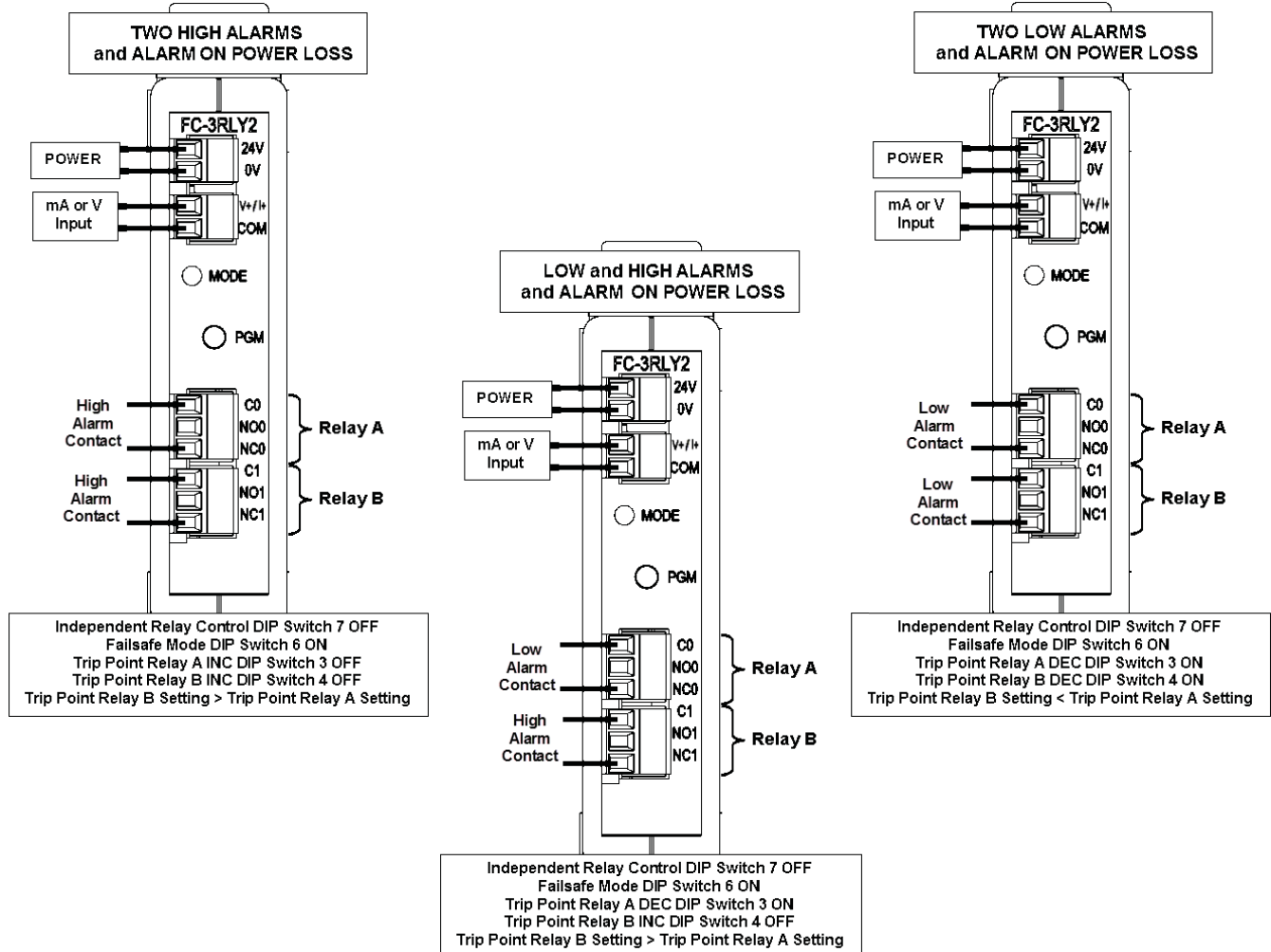

Non-Latching and Latching Relay Control Modes

Non-Latching Relay Control Mode [DIP Switch 8 OFF]

Relays A and B operate automatically at the Trip and Release Point settings

2

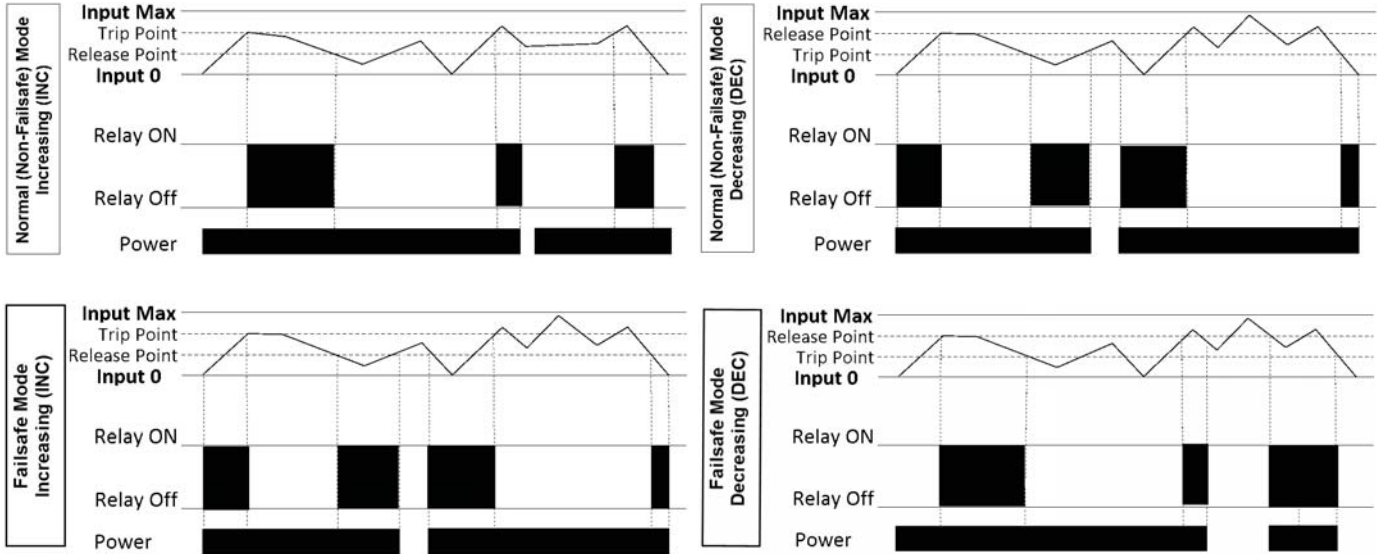

Latching Relay Control Mode [DIP Switch 8 ON]

Relays A and B operate automatically at the Latch Trip Point settings and remain **electrically** latched until the input signal reaches the Manual Release Point. The FC-3RLY2 relays can be manually reset by pressing the PGM-button as shown in the following diagrams. Latching Relay Control Mode is available in both Normal and Failsafe Modes.



CAUTION: Relays are electrically (not mechanically) latched. Any energized relays and connected loads will de-energize if power is removed from the FC-3RLY2 and may re-energize when power is reapplied.

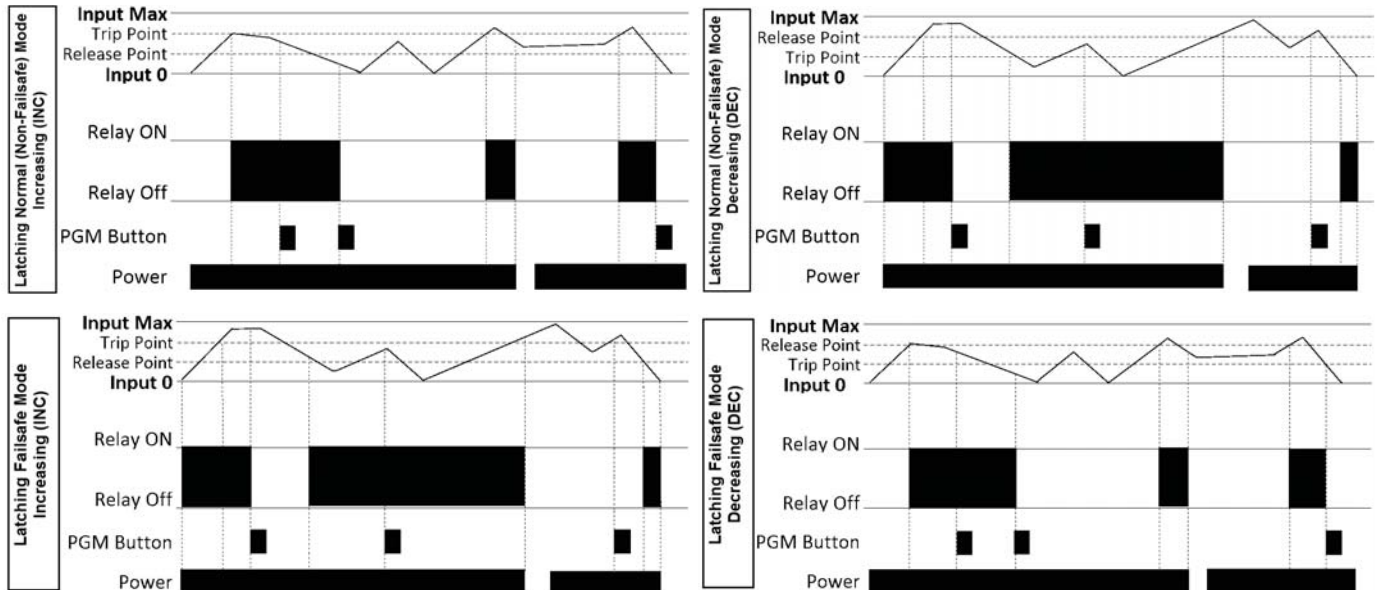

Custom Trip Point Programming with Factory Release Point Dead-band

If your application requires Custom Release Points refer to next section



NOTE: If you make a mistake while in programming mode you can quickly exit and start over by cycling power to the FC-3RLY2 or simply press the PGM pushbutton repeatedly until the MODE LED turns green.

Programming Worksheet

Input Signal _____

Normal or Failsafe Mode _____

Increasing (INC) or Decreasing (DEC) _____

Non-latching or Latching Mode _____

Independent or Simultaneous Mode _____

Relay A Trip Point _____

Relay A Factory Deadband (2.5% * Voltage Input Range or 1.5mA) _____

Relay A Release Point if Increasing (INC) Mode $RP=TP-DB$ _____

Relay A Release Point if Decreasing (DEC) Mode $RP=TP+DB$ _____

Relay B Trip Point _____

Relay B Factory Deadband (2.5% * Voltage Input Range or 1.5mA) _____

Relay B Release Point if Increasing (INC) Mode $RP=TP-DB$ _____

Relay B Release Point if Decreasing (DEC) Mode $RP=TP+DB$ _____



NOTE: In Simultaneous Mode, Relay B Trip Point and Release Point are automatically set the same as Relay A.



WARNING: Disconnect all loads from the output relays BEFORE programming. Output relays can turn ON and OFF during programming causing potentially unsafe conditions if loads are connected!!!

Programming Flowchart: Custom Trip Points with Factory Release Point Dead-band Independent Relay Control [DIP Switch 7 OFF]

2

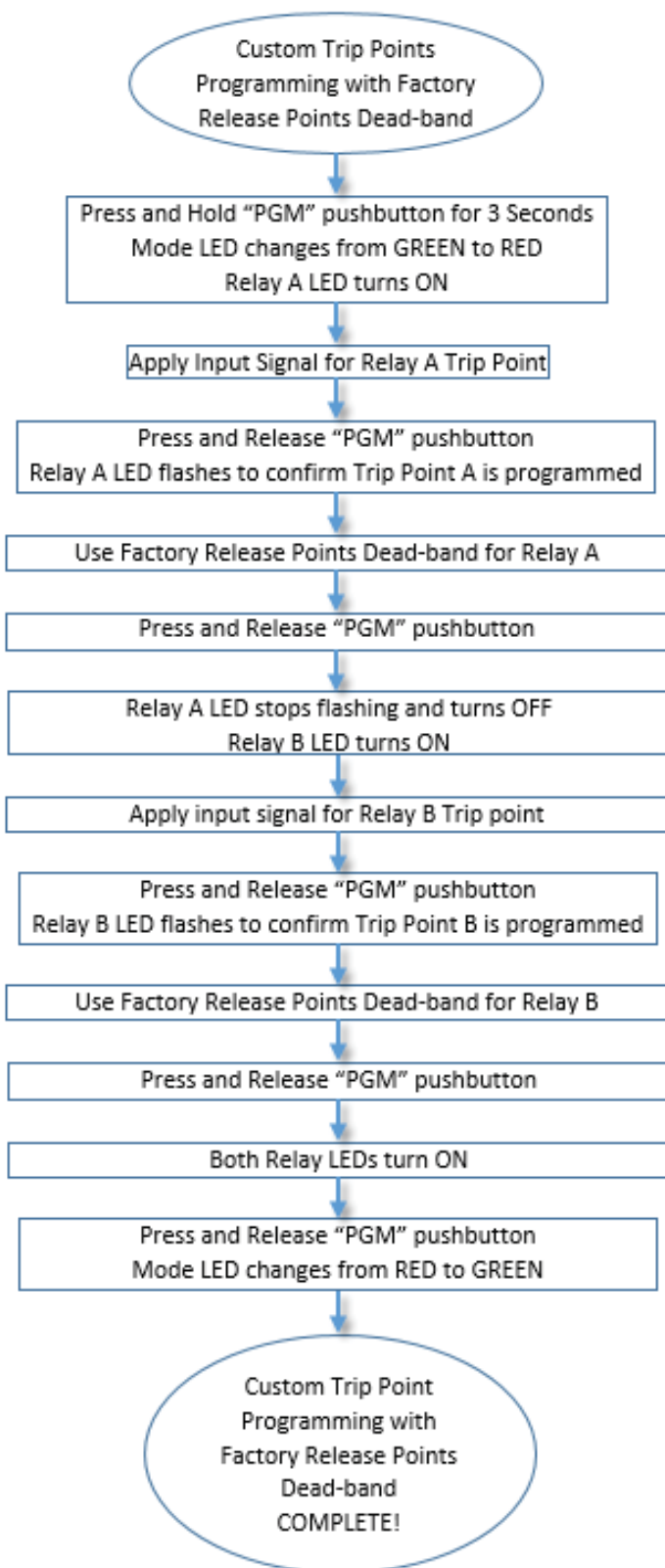

NOTE: If you make a mistake while in programming mode you can quickly exit and start over by cycling power to the FC-3RLY2 or simply press the PGM pushbutton repeatedly until the MODE LED turns green.

Programming Flowchart: Custom Trip Points with Factory Release Points Dead-band Simultaneous Relay Control [DIP Switch 7 ON]

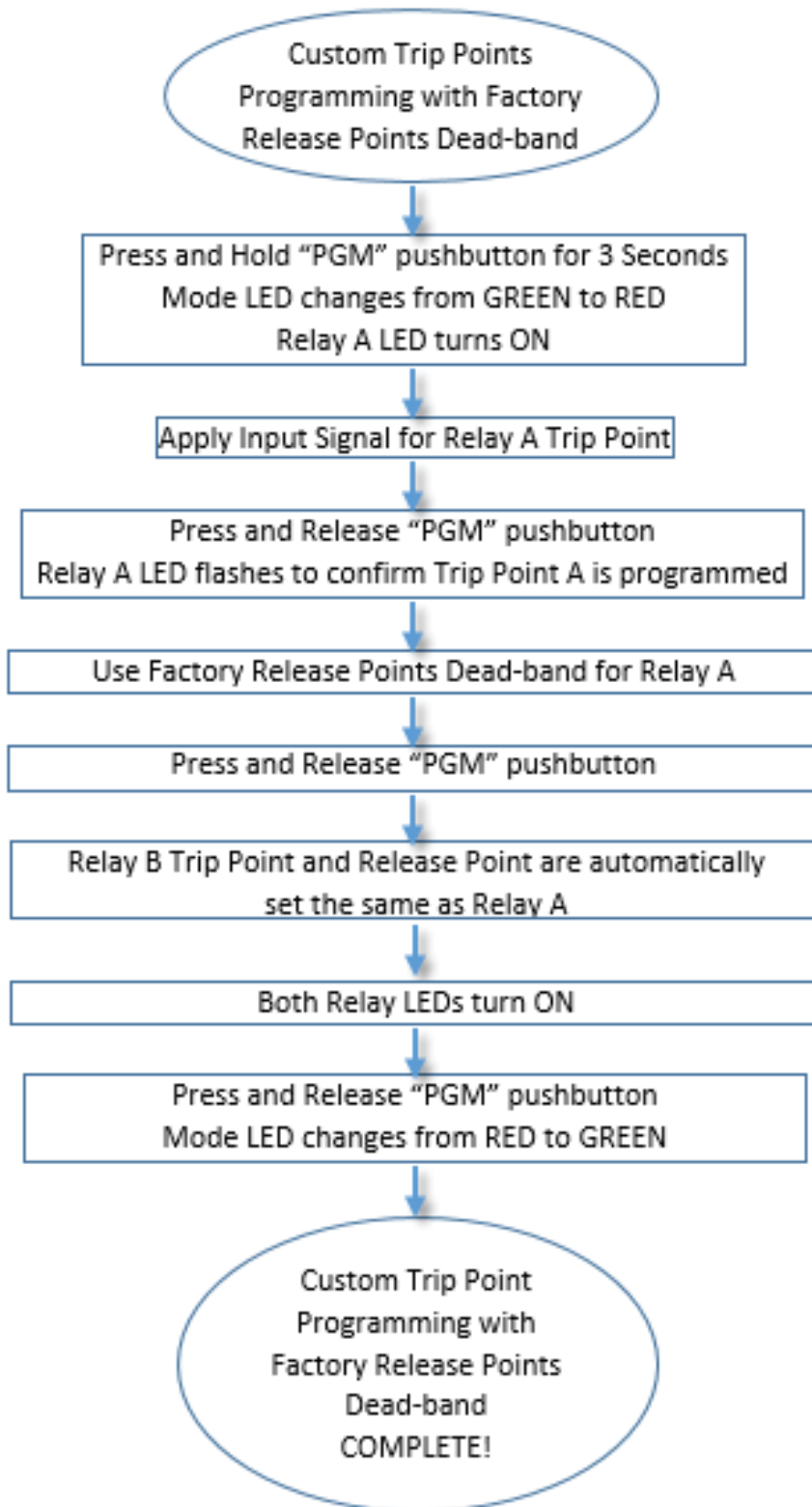

NOTE: If you make a mistake while in programming mode you can quickly exit and start over by cycling power to the FC-3RLY2 or simply press the PGM pushbutton repeatedly until the MODE LED turns green.

Custom Trip Point Programming with Custom Release Points

If your application does not require Custom Release Points refer to previous section

2



NOTE: If you make a mistake while in programming mode you can quickly exit and start over by cycling power to the FC-3RLY2 or simply pressing the PGM pushbutton repeatedly until the MODE LED turns green.

Programming Worksheet

Input Signal _____

Normal or Failsafe Mode _____

Increasing (INC) or Decreasing (DEC) _____

Non-latching or Latching Mode _____

Independent or Simultaneous Mode _____

Relay A Trip Point _____

Relay A Release Point (must be <TP if Increasing Mode (INC),
must be >TP if Decreasing Mode (DEC)) _____

Relay B Trip Point _____

Relay B Release Point (must be <TP if Increasing Mode (INC),
must be >TP if Decreasing Mode (DEC)) _____



WARNING: Disconnect all loads from the output relays *BEFORE* programming. Output relays can turn ON and OFF during programming causing potentially unsafe conditions if loads are connected!!!

Programming Flowchart: Custom Trip Points with Custom Release Points Independent Relay Control [DIP Switch 7 OFF]



NOTE: If you make a mistake while in programming mode you can quickly exit and start over by cycling power to the FC-3RLY2 or simply press the PGM pushbutton repeatedly until the MODE LED turns green.

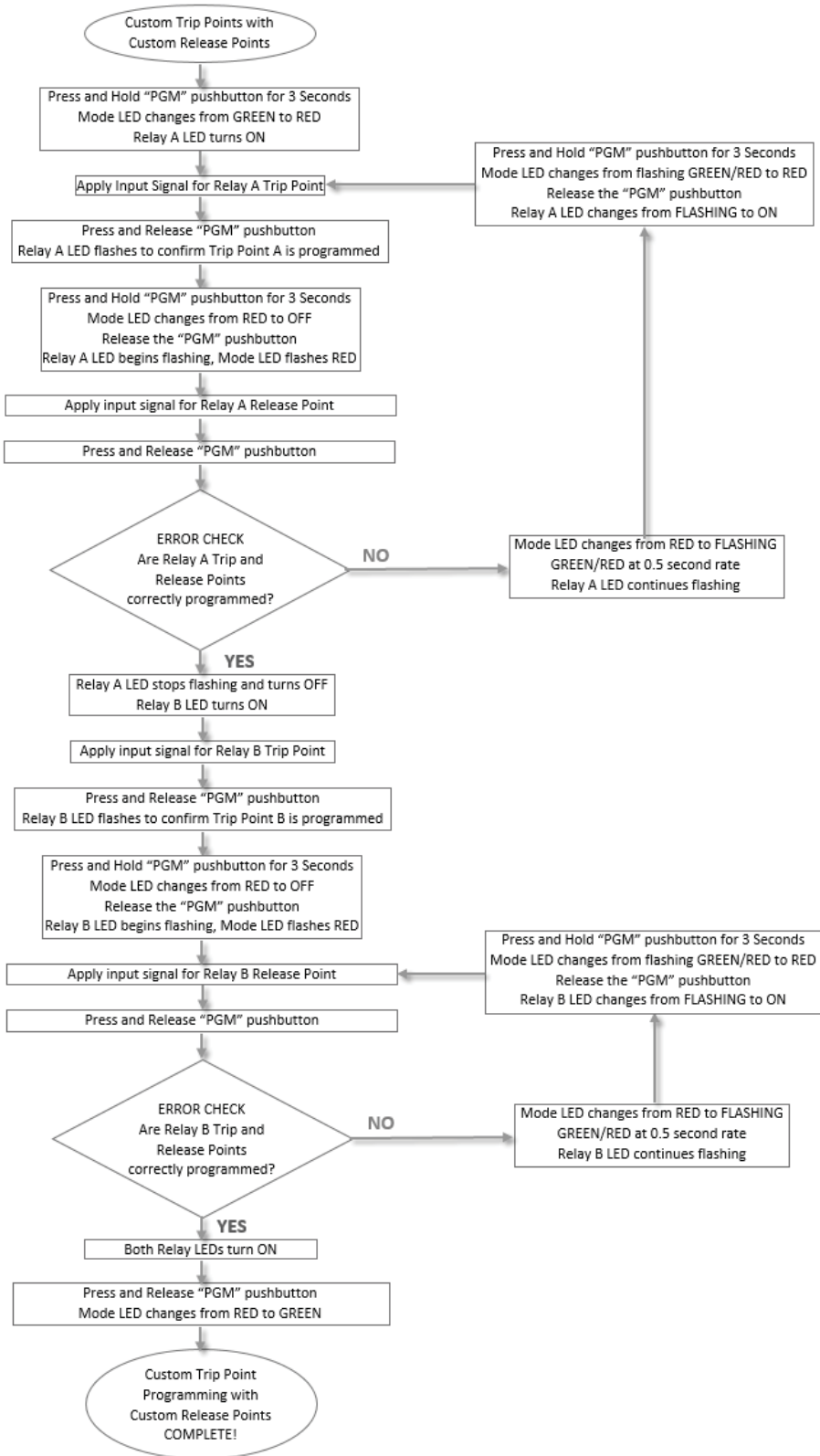

Programming Flowchart: Custom Trip Points with Custom Release Points Simultaneous Relay Control [DIP Switch 7 ON]

2



NOTE: If you make a mistake while in programming mode you can quickly exit and start over by cycling power to the FC-3RLY2 or simply press the PGM pushbutton repeatedly until the MODE LED turns green.

