

GazTell

Fixed Point Carbon Monoxide Electrochemical Detector Head with EXMO and SLAM

Reference:

Quotation No:

Date:

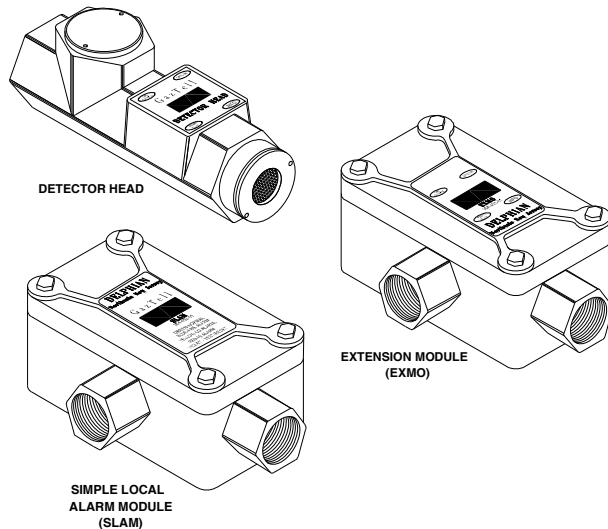

Assembly Design

- Modular component design: the detector head can be used alone or with the extension module (EXMO) which will display all the information from the detector head and perform all of its functions. The optional SLAM has relays for Fail, Low and High alarms and has a multi-color LED for system alerts.
- 100% quality tested.
- The detector head (and extension module) shows system warnings and failures.
- Built-in selftest continuously monitors hardware and software.
- Calibration required infrequently.
- RFI and surge protection circuits built in.
- Options include Splash/Dust Guard, Ported Adaptor, Reclamation Adaptor, Collection Cone, Wye Pipe Adaptor, Duct Mounting Plate, Lightning Arrestor and MODBUS RTU Communications Module (COMO).

Construction

- Stand-alone. Modular construction which makes wiring easy and permits rapid replacement of components.
- Sensor and conduit box are explosion proof.
- The internal sensor components and all connectors exposed to the atmosphere are gold plated.
- All connectors are unique and are keyed to prevent incorrect connections.
- The detector electronics are encapsulated to prevent deterioration from dust and humidity.
- No moving parts.

Specifications

Dimensions: Detector Head 5"L x 2"W
EXMO & SLAM 6"L x 3.5"W x 2"H

Shipping Weight: Detector Head .875 lbs (.4 kg)
EXMO & SLAM 1.25 lbs (.6 kg)

Power: Detector Head: 40mA max; EXMO 16mA max; SLAM 56mA max

Output Signal:

Range 4 - 20mA or 1 - 5mA (4 - 20mA is default)

Output is linear and proportional to the gas scale.

Load (maximum resistance) 300 Ohms

Scales (Detection Ranges):

0 - 100 ppm (0 ppm = 4.0mA, 100 ppm = 20mA), over range to 22mA (112 ppm) - shipped with the 0 - 100 range selected

0 - 300 ppm (0 ppm = 4.0mA, 300 ppm = 20mA), over range to 22mA (337 ppm)

0 - 1000 ppm (0 ppm = 4.0mA, 1000 ppm = 20mA), over range to 22mA (1125 ppm)

Cell Operating Range: 0 to 1,000 ppm

Saturation (Maximum Overload): 2,000 ppm

Temperature Range:

Continuous Operating Temperature Range: -30°C to +50°C (-22°F to +122°F)

Storage Temperature Range: 0°C to +20°C (+32°F to +68°F)

Interfering Gas	Concentration	Equivalent CO Signal
C ₂ H ₄ Ethylene	100 ppm	< 90 ppm
H ₂ Hydrogen	100 ppm	< 60 ppm
H ₂ S Hydrogen Sulfide	15 ppm	< 0.1 ppm
NO Nitric Oxide	35 ppm	< 7 ppm
SO ₂ Sulfur Dioxide	5 ppm	0 ppm

Blocking Gases:

Carbon Monoxide is oxidized at the anode; reducible gases such as Nitrogen Oxides and Chlorine create an opposite reaction and will cause some blocking of the CO reaction.

NO₂ 5 ppm (CO signal -0.5 ppm)

Not all possible interfering and blocking gases have been tested.

Poisoning Gases: High concentrations of solvent vapors, alcohols, phenols, pyridine, ketones, amines, acetylene and chlorinated solvents can attack the cell.

Expected Operating Life in Air at 70°F: >24 months

Operating Pressure Range: Atmospheric +/- 10%

Operating Relative Humidity Range: 15 - 90% RH (relative humidity) non condensing (continuous).

Response Time: T50 ≤ 20 seconds, T90 ≤ 40 seconds

Recovery Time: Recovery time to 10% of final value is ≤ 53 seconds.

Accuracy: ± 10% of reading.

Repeatability: ± 10% of reading.

Resolution: 1 ppm

Long Term Drift: < 20% per year

Warm-up Time: Less than 1 minute to operational.

Stabilization Time:

Initial stabilization time to specification may take from 4 to 12 hours depending on ambient conditions.

Warranty Period: 12 months in Air at S.T.P. (from date of shipment)

SLAM Relays: 6 amps @ 120 volts

SLAM Response Time: Less than a second from the time the Detector Head sees sufficient gas to trigger an alarm to the relay operating.

EXMO Response Time: Less than a second from the time the Detector Head sees gas to the EXMO displaying that gas concentration.



DELPHIAN CORPORATION

220 Pegasus Avenue, Northvale, NJ 07647 U.S.A.

Tel: 201-767-7300 Fax: 201-767-1741

www.delphian.com

DELPHIAN

NOTICE: The information in this document is subject to change without notice. Not all possible interfering, blocking or poisoning gases have been tested. This document is provided in good faith but without warranty of any kind. It could include technical inaccuracies or typographical errors. The GazTell Owners Manual should be consulted if more information is required.