

B450TSB Filament Lamp Traffic Light

The B450 series of traffic light beacons are available in single E27 filament lamp, dual E14 filament lamp or high output L.E.D array versions.

Features

- Bayonet fixing lens.
- Anti-tamper locking screw.
- Stainless steel fixings.

Approvals

- GOST-R certificate: POCC GB.JB05.H00144.



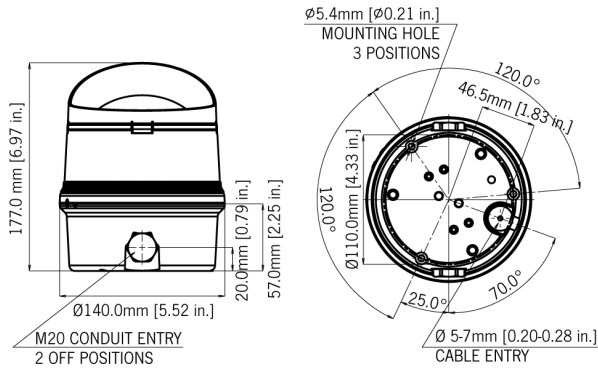

Specification

Light source:	Filament Lamp E27
Light output:	25W
Function:	Permanent
L.E.D. colours:	Amber, Blue, Clear, Green, Red & Yellow
Effective Intensity cd:	32 cd* (peak/effective intensity)
Lens type:	Prismatic
Mounting:	Surface mount (Wall mount bracket available)
Entries:	1 x 5-7mm push through grommet 2 x M20 cable entry
Dimensions:	ø140 x 177mm
Ingress protection:	IP65
Housing material:	High impact UL94 V0 (f1) PC
Terminals:	0.5 to 2.5mm ²
Operating temp:	-25 to +50°C [-13° to +122 °F]
Storage temp:	-40 to +70°C [-40° to +158°F]
Relative humidity:	90% at 20°C [68°F]
*Candela measurements representative of performance with clear lens at optimum voltage.	

Part Codes

Version:	Part code:
12-250V	B450TSB250B/[x]
[x] = Lens colour:	A: Amber B: Blue C: Clear G: Green R: Red Y: Yellow

Note: Filament lamps not included.
Must be ordered separately

Mounting brackets:

MB-B450T-S	Mounting bracket kit for a single B450 type unit.
MB-B450T-M	Mounting bracket kit for linked multiple B450 type units.

Note: Multiple unit connector is supplied with each product.

Filament lamp part codes:

Version:	Wattage:	Type:	Part code:
24V dc	25W	E27	BGS2525C27
115V ac	25W	E27	BGS11025C27
230V ac	25W	E27	BGS24025C27

Note: Filament lamps to be ordered separately.

AUTHORIZED DISTRIBUTOR:
GasDetectorsUSA.com
Houston, Texas USA
sales@GasDetectorsUSA.com
832-615-3588