



INSTRUCTION MANUAL (ATEX / IECEx)

BExDTS110D Flameproof Sontel

For use in Flammable Gas and Dust Atmospheres

1) Introduction

The BExDTS110D is a flameproof Sontel telephone sounder which is certified to meet the requirements of the ATEX directive 94/9/EC and IECEx scheme. The Sontel produces a loud audible signal when triggered by a telephone ringing signal and can be used in hazardous areas where potentially flammable gas and dust atmospheres may be present. Thirty-two different sounds can be selected by internal switches (see *tone table on Page 4*). The BExDTS110D unit produces output levels in the 110dB(A) range. The unit can be used in Zone 1 and Zone 2 areas with gases in groups IIA, IIB and IIC and temperature Classifications of T1, T2, T3 and T4. For ambient temperatures over +55°C the gas groups are limited to IIA and IIB. They can also be used in Zone 21 and Zone 22 areas for combustible dusts and have an IP rating of IP 67 and a surface temperature rating of T100°C up to +55°C and T115°C over +55°C.

2) Marking

All units have a rating label, which carries the following important information:-

Unit Type No. BExDTS110D

Input Voltage: DC Units: 12V or 24V or 48V
AC Units: 230V or 110V or 115V

Codes: Ex d IIC T4 for Ta -50°C to +55°C
Ex d IIB T4 for Ta -50°C to +70°C
Ex tD A21 IP67 T115°C based on max Ta of +70°C

Certificate No's KEMA 99ATEX6312
IECEX KEM 10.0003

Epsilon x:  II 2G/D
Equipment Group and Category:

CE Marking  0518
Notified Body No.

“Warnings” DO NOT OPEN WHEN AN EXPLOSIVE GAS OR DUST ATMOSPHERE IS PRESENT

COVER BOLTS CLASS A4-80

USE HEAT RESISTING CABLES AND CABLE GLANDS (Rated 110°C) AT AMB. TEMPERATURES OVER 40°C

Year of Construction / Serial No. i.e. 10 / 1DTS23000001

3) Type Approval Standards

The Sontel has EC Type Examination and IECEx certificates issued by KEMA and has been approved to the following standards:-

EN60079-0:2006	IEC60079-0:2004 (Ed4)	General Requirements
EN60079-1:2007	IEC60079-1:2007 (Ed6)	Flameproof Enclosure 'd'
EN61241-0:2006	IEC61241-0:2004 (Ed1)	Dust General Requirements
EN61241-1:2004	IEC60079-1:2004 (Ed1)	Dust Enclosures 'd'

4) Installation Requirements

The Sontels must be installed in accordance with the latest issues of the relevant parts of the EN 60079 standards or the equivalent IEC standards – Selection, Installation and maintenance of electrical apparatus for use in potentially explosive atmospheres (other than mining applications or explosive processing and manufacture):-

EN60079-14:2008	Electrical Installations in Hazardous Areas (other than mines)
IEC60079-14:2007 (Ed4)	
EN60079-10:2003	Classification of Hazardous Areas
IEC60079-10:2008 (Ed1)	

The installation of the units must also be in accordance with any local codes that may apply and should only be carried out by a competent electrical engineer who has the necessary training.

5) Zones, Gas Group, Category, IP Rating and Temperature Classification

The BExDTS110D Sontels have been certified Ex d IIC T4 for Ta -50°C to +55°C and Ex d IIB T4 for Ta -50°C to +70°C for gas and Ex tD A21 IP67 T115°C based on max. Ta of +70°C for dust. This means that the units can be installed in locations with the following conditions:-

Area Classification Gas:

Zone 1	Explosive gas air mixture likely to occur in normal operation.
Zone 2	Explosive gas air mixture not likely to occur, and if it does, it will only exist for a short time.

Gas Groupings:

Group IIA	Propane
Group IIB	Ethylene
Group IIC (Up to +55°C only)	Hydrogen and Acetylene

Temperature Classification:

T1	400°C
T2	300°C
T3	200°C
T4	135°C

Area Classification Dust:

Zone 21	Explosive dust air mixture likely to occur in normal operation.
Zone 22	Explosive dust air mixture not likely to occur, and if it does, it will only exist for a short time.

IP Rating: IP67 T100°C Ta ≤ +55°C
T115°C Ta ≤ +70°C

Equipment Category: 2G/D

Ambient Temperature Range:

-50°C to +55°C Gas Groups IIA, IIB and IIC
-50°C to +70°C Gas Group IIA and IIB

6) Sontel Location and Mounting

The location of the Sontels should be made with due regard to the area over which the warning signal must be audible. And they should only be fixed to services that can carry the weight of the unit.

The Sontels should be securely bolted to a suitable surface using the 7mm diameter boltholes in the stainless steel U shaped mounting bracket (see figure 1). The angle can then be adjusted in the direction that the sound is primarily required to cover. This can be achieved by loosening the two large bracket screws in the side of the unit, which allow adjustment in steps of 18°. On completion of the installation the two large bracket adjustment screws on the side of the unit must be fully tightened to ensure that the unit cannot move in service.

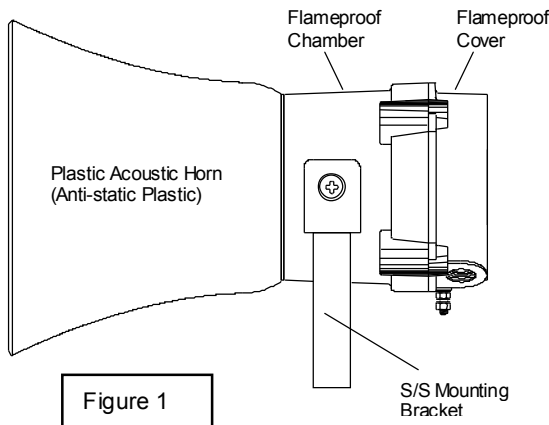

Figure 1

7) Access to the Flameproof Enclosure

In order to connect the electrical supply cable and the telephone line cable to the Sontel it is necessary to remove the flameproof cover to gain access to the flameproof chamber.

To achieve this remove the four M6 hexagon socket head screws (see figure 2) and withdraw the flameproof cover taking extreme care not to damage the flameproof joints in the process.

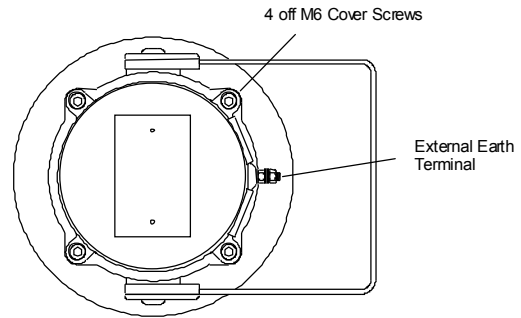

Figure 2

Note the four **M6 screws** are **Class A4-80 stainless steel** and **only screws of this category can be used on these Sontels**. It is therefore important that these screws and their spring washers are kept in a safe place during installation.

On completion of the cable wiring installation the flameproof joints should be inspected to ensure that they are clean and that they have not been damaged during installation. Also check that the earth bonding wire between the two casting sections is secure and the 'O' ring seal is in place. When replacing the flameproof cover casting ensure that it is square with the flameproof chamber casting before inserting. Carefully push the cover in place allowing time for the air to be expelled. Only after the cover is fully in place should the four M6 Stainless Steel A4-80 cover bolts and their spring washer be inserted and tightened down. If the cover jams while it is being inserted, carefully remove it and try again. Never use the cover bolts to force the cover into position.

8) Power Supply Selection

It is important that a suitable power supply is used to run the Sontels.

The following table shows the input current taken by the various units:-

Unit Type	Input Voltage	Input Current	Max. I/P Volts
BExDTS110D	24V DC	265mA	30V
BExDTS110D	12V DC	195mA	15V
BExDTS110D	48V DC	130mA	58V
BExDTS110D	230V AC	56mA	264V
BExDTS110D	110V AC	93mA	121V
BExDTS110D	115V AC	110mA	126V

The input current will vary according to the voltage input level and the frequency of the tone selected. The current levels shown above are for the 440Hz Continuous tone @ nominal input voltage. The units have a switching voltage regulator circuit and therefore the input current level will decrease slightly as the input voltage is increased and will increase slightly as the input voltage is reduced.

The above table also shows the maximum voltages at which the Sontels can be operated.

9) Cable Selection

When selecting the cable size consideration must be given to the input current that each unit draws (see table above), and the length of the cable runs.

SAFETY WARNING: If the high output BExDTS110D units are used at high ambient temperatures, i.e. over +40°C, then the cable entry temperature may exceed +70°C and therefore suitable heat resisting cables must be used, with a rated service temperature of at least 110°C.

10) Earthing

The Sontel units must be connected to a good quality earth. The units are provided with internal and external earthing terminals which are both located on the terminal chamber section of the unit (see figures 2 and 3).

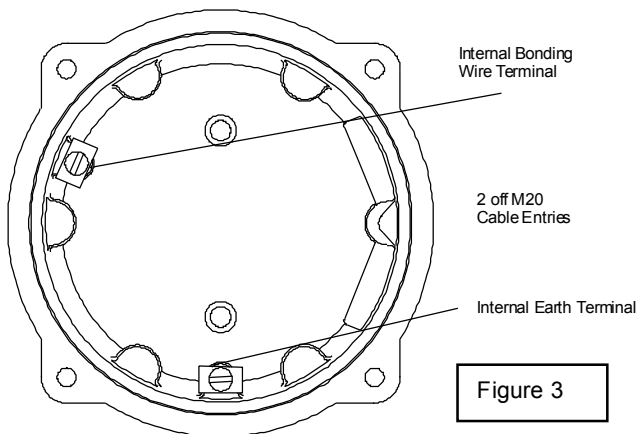

When using the internal earth terminal ensure that the stainless steel M4 flat washer is between the incoming earth wire and the enclosure.

When using the internal earth terminal ensure that the stainless steel M4 flat washer is between the incoming earth wire and the enclosure.

When using the external earth terminal a cable crimp lug must be used. The cable lug should be located between the two M5 stainless steel flat washers. The M5 stainless steel spring washer must be fixed between the outer flat washer and the M5 stainless steel nut to ensure that the cable lug is secured against loosening and twisting.

The internal earth bonding wire ensures that a good quality earth is maintained between the flameproof chamber casting and the flameproof cover casting.

11) Cable Glands

The BExDTS110D Sontels have dual cable gland entries which have an M20 x 1.5 as standard. Only cable glands approved for Ex 'd' applications can be used, which must be suitable for the type of cable being used and also meet the requirements of the Ex 'd' flameproof installation standard EN60079-14:2008 / IEC60079-14:2007.

When only one cable entry is used the other one must be closed with an Ex 'd' flameproof blanking plug, which must be suitably approved for the installation requirements.

For combustible dust applications, the cable entry device and blanking elements shall be in type of explosion protection increased safety "e" or flameproof enclosure "d" and shall have an IP 6X rating according to EN 60529.

SAFETY WARNING: If the BExDTS110D Sontels are used at high ambient temperatures, i.e. over +40°C, then the cable entry temperature may exceed +70°C and therefore suitable heat resisting cable glands must be used, with a rated service temperature of at least 110°C.

12) Cable Connections

The cable connections are made into the terminal blocks on the Sontel pcb assembly located in the flameproof enclosure. See section 7 of this manual for access to the flameproof enclosure. The printed circuit board has two terminal blocks; one for the power supply input voltage and one for the telephone signal input cable (see figures 4 and 5). The power input cable should enter the enclosure via one of the M20 cable entries and be connected to the supply terminals (L and N) AC units (+ve and -ve) DC units and the telephone signal cable should enter the enclosure via the other M20 entry and be connected to the telephone terminal.

A single wire with a cross sectional area of up to 4mm² can be connected to each terminal way. When connecting wires to the terminals great care should be taken to dress the wire so that when the cover is inserted into the chamber the wires do not exert excess pressure on the terminal blocks. This is particularly important when using cables with large cross sectional areas such as 2.5mm² and above.

BExDTS110D AC Sontels

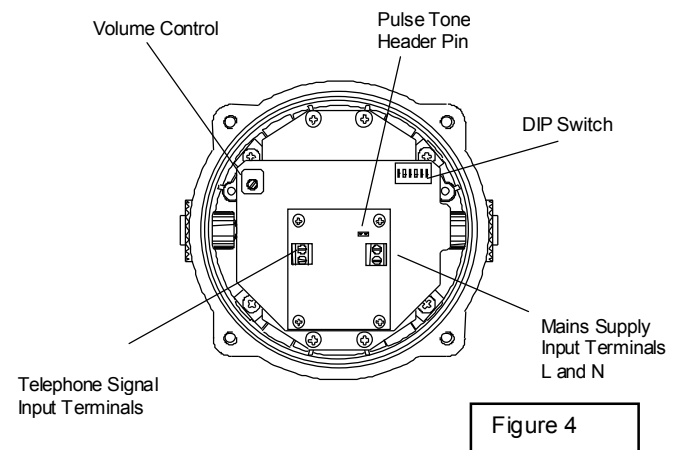

BExDTS110D DC Sontels

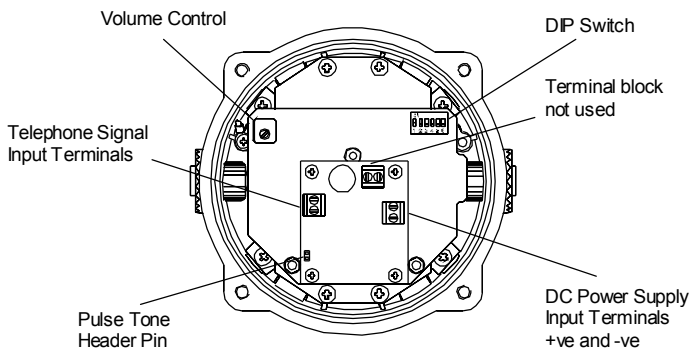

Figure 5

13) Tone Selection

The BExDTS110D Sontels have 32 different tones that can be selected by the DIP switches on the sounder pcb (see figures 4 and 5). The tone table on page four shows the switch positions for the 32 tones.

14) Pulse Tone Operation

The BExDTS110D Sontel has two modes of operation continuous tone operation and pulsed tone operation. To select continuous tone operation the pulse tone header pins should not be shorted (see figures 4 and 5). In this mode the output tone will be as per the tone table. To select pulse tone operation the pulse tone header pins should be shorted (see figures 4 and 5). In this mode of operation the selected tone pattern will pulse on and off following the telephone input signal. Note if pulsed tone operation is selected it is advisable not to select any of the intermittent tones, such as tone 11.

15) Volume Control

The BExDTS110D Sontel has a volume control to adjust the output level. To set the required output level, adjust the potentiometer on the sontel pcb (see figure 4). For maximum output level the potentiometer should be set to the fully clockwise position.

TONE SELECTION TABLE

Note Switch No. 6 is not used

Tone Selection		DIP Switch Settings				
Stage 1	Frequency Description	1	2	3	4	5
1	Continuous 1000Hz <i>Toxic gas alarm</i>	0	0	0	0	0
2	Alternating 800/1000Hz at 0.25s intervals	1	0	0	0	0
3	Slow Whoop 500/1200Hz at 0.3Hz with 0.5s gap repeated	0	1	0	0	0
4	Sweeping 800/1000 at 1Hz	1	1	0	0	0
5	Continuous at 2400Hz	0	0	1	0	0
6	Sweeping 2400/2900Hz at 7Hz	1	0	1	0	0
7	Sweeping 2400/2900Hz at 1Hz	0	1	1	0	0
8	Sine 500/1200/500Hz at 0.3Hz	1	1	1	0	0
9	Sawtooth 1200/500Hz at 1Hz	0	0	0	1	0
10	Alternating 2400/2900Hz at 2Hz	1	0	0	1	0
11	Intermittent 1000Hz at 0.5Hz <i>General alarm</i>	0	1	0	1	0
12	Alternating 800/1000Hz at 0.875Hz	1	1	0	1	0
13	Intermittent 2400Hz at 1Hz	0	0	1	1	0
14	Intermittent 800Hz 0.25s on 1s off	1	0	1	1	0
15	Continuous at 800Hz	0	1	1	1	0
16	Intermittent 660Hz 150mS on, 150mS off	1	1	1	1	0
17	Alternating 544Hz (100mS)/440Hz(400mS)	0	0	0	0	1
18	Intermittent 660Hz 1.8s on, 1.8s off	1	0	0	0	1
19	1400Hz to 1600Hz sweep up over 1s - 1600Hz to 1400Hz sweep down over 0.5s	0	1	0	0	1
20	Continuous 660Hz	1	1	0	0	1
21	Alternating 554/440Hz at 1Hz	0	0	1	0	1
22	Intermittent 554Hz at 0.875Hz	1	0	1	0	1
23	800Hz pulsing at 2Hz	0	1	1	0	1
24	Sweeping 800/1000Hz at 50Hz	1	1	1	0	1
25	Sweeping 2400/2900Hz at 50Hz	0	0	0	1	1
26	Simulated bell sound	1	0	0	1	1
27	Continuous 554Hz	0	1	0	1	1
28	Continuous 440Hz	1	1	0	1	1
29	Sweeping 800/1000Hz at 7Hz	0	0	1	1	1
30	420Hz repeating 0.625s on, 0.625s off <i>Australian alert signal</i>	1	0	1	1	1
31	1200/500Hz at 1 Hz <i>Prepare to abandon platform</i>	0	1	1	1	1
32	Sweeping 500/1200Hz 3.75s on, 0.25s off 15Hz	1	1	1	1	1

EC DECLARATION OF CONFORMITY



Manufacturer: European Safety Systems Ltd.
Impress House, Mansell Road, Acton
London, W3 7QH, UK

Equipment Type: BExS110D, BExS120D, BExS110E, BExS120E,
BExDS120D, BExDS110D, BExDS120E, BExDS110E,
BExL25D, BExL15D, BExL25E, BExL15E,
BExDL25D, BExDL15D, BExDL25E, BExDL15E,
BExA110D, BExA120D, BExA110E, BExA120E,
BExDA110D, BExDA120D, BExDA110E, BExDA120E,
BExTS110D, BExDTS110D, BExH120D, BExDH120D, BExL25GD, BExDL25GD

Directive 94/9/EC: Electrical and Mechanical equipment for use in explosive atmospheres (ATEX)

Notified Body for EC type Examination: KEMA Quality B.V.
Notified Body No.: 0344
Utrechtseweg 310, 6812 AR Arnhem, The Netherlands

EC-type Examination Certificate: KEMA 99ATEX6312

Notified Body for Quality Assurance Notification: Sira Certification Service
Notified Body No.: 0518
Rake Lane, Eccleston, Chester CH4 9JN, UK

Quality Assurance Notification: SIRA 05 ATEX M342

Provisions fulfilled by the equipment: II 2 G Ex d IIB or IIC T4 or
II 2 G Ex de IIB or IIC T4
II 2 D Ex tD A21 IP66 or IP67 T100 °C or T115 °C

Standards applied: EN 60079-0:2006
EN 60079-1:2007
EN 60079-7:2003
EN 61241-0:2006
EN 61241-1:2004

Directive 89/106/EEC: Construction Products Directive (CPD) – BExS110D24DC / BExS120D24DC (tones 2, 3, 9, 15, 16, 17) only

Notified Body for EC type Examination: VdS Schadensverhütung GmbH
Notified Body No.: 0786
Amsterdamer Str 172-174, 50735 Köln, Germany

EC-type Examination Certificate: 0708-CPD-20225

Standards applied: EN 54-3:2001 + A1:2002

Directive 2009/26/EC: Marine Equipment Directive (MED) – BExS110D24DC-M only

Notified Body for EC type Examination: Germanischer Lloyd SE
Notified Body No.: 0098
Brooktorkai 18, 20457 Hamburg, Germany

EC-type Examination Certificate: 19 702 - 11 HH

Standards applied: EN 54-3:2001 + A1:2002 + A2:2006
IEC 60092-504: 2001
IEC 60533: 1999

Directive 2004/108/EC: Electromagnetic Compatibility Directive (EMC)

Standards applied: EN 61000-6-1:2007
EN 61000-6-2:2005
EN 61000-6-3:2007
EN 61000-6-4:2007

The standards EN 60079-0: 2006, EN 60079-7:2003, EN 61241-0:2006 and EN 61241-1:2004 are no longer harmonized. The requirements of these standards have been checked against the harmonized standards EN 60079-0:2009, EN 60079-7:2007 and EN 60079-31:2009 and there were no major technical changes affecting the latest technical knowledge for the products listed above.

On behalf of European Safety Systems Ltd., I declare that, on the date the equipment accompanied by this declaration is placed on the market, the equipment conforms with all technical and regulatory requirements of the above listed directives.

A handwritten signature in black ink, appearing to read 'Martin Streetz'.

Martin Streetz
Quality Assurance Manager

Telephone: +44 (0)20 8743 8880
Facsimile: +44 (0)20 8740 4200
E-mail: sales@e2s.com
www.e2s.com

Date and Place of Issue: London, 04/07/2012
Document No: DC-001-Issue_C

European Safety Systems Ltd
Company Registration No. 2763350
Registered Office: Impress House
Mansell Road, London, UK, W3 7QH, UK