

D1xC2X05R Radial Alarm Horn & Xenon Strobe

The D1xC2X05R is a high output 118dB(A) alarm horn with omni-directional radial horn & 5 Joule Xenon strobe. The robust Type 4/4X, IP66 marine grade, corrosion proof LM6 enclosure ensures suitability for all Class I/II Div 1, Zone 1/20 applications.

The alarm horn & Xenon strobe allow simultaneous or independent operation. Featuring 64 first stage/channel alarm sounds, the alarm tone frequencies for the first 2 stages are independently selectable. Each of the 4 stage/channels can be remotely triggered e.g. via an external relay. The Class I DC version is approved for public mode fire alarm use (alarm horn) and private mode fire alarm use (strobe beacon).

Features

- Automatic synchronisation on multi sounder systems.
- User selectable strobe flash rates
- Ratchet adjustable stainless steel 'U' bracket.
- High output omni-directional alarm horn, up to 118dB(A)
- Xenon strobe – private mode fire alarm use (Class I version)
- Alarm horn – public mode fire alarm use (Class I version)
- 4 remotely selectable alarm stages/channels
- Positive or negative line stage/channel switching
- Choice of 64 alarm tone frequencies
- Compact form factor
- Robust corrosion proof aluminium enclosure
- Stainless steel fixings
- Triple cable entries
- Duplicate cable terminations

Approvals

- UL File ref: E230764
UL 1203 Ed. 5
CAN/CSA C22.2 No. 25-1966
CSA C22.2 No. 30-M1986
CSA C22.2 No. 205-12
UL464 Ed. 9
UL1638 Ed. 4
- CSFM listing: 7136-2279:0506

Coding

- **A1: Gas version**
NEC / CEC:
Class I Div 1 ABCD T5/T6 Ta -40°C to +55/+50°C
Class I Div 2 ABCD T5/T6 Ta -40°C to +55/+50°C
Class I Zone 1, 2 IIC T5/T6 Ta -40°C to +55/+50°C
- **D1: Dust version**
NEC / CEC:
Class II Div 1 FG T4/T4A Ta -40°C to +55/+40°C
Class II Div 2 FG T4/T4A Ta -40°C to +55/+40°C
Class III Div 1 & 2
Zone 20, 21, 22 IIIB T4/T4A Ta -40°C to +55/+40°C
- Protection concept: Ex d / AEx d



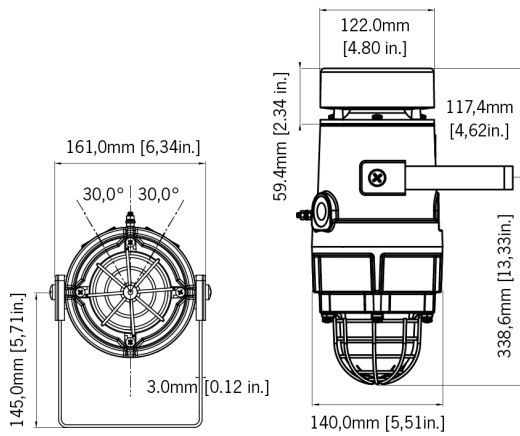

Specification

Alarm Horn:

Maximum output: Class I version: 118dB(A) @ 1 metre [109dB(A) @ 10ft/3m]

Class II version: 99dB(A) @ 1 metre [90dB(A) @ 10ft/3m]

Nominal output: Class I version: 112dB(A) @ 1m +/- 3dB - Tone 4 [103dB(A) @ 10ft/3m]

Class II version: 93dB(A) @ 1 metre [84dB(A) @ 10ft/3m]

No. of tones: 64 (UK00A / PFEER compliant)

No. of stages: 4

Volume control: Adjustable -12dB(A)

Effective range: 125m/410ft @ 1KHz

Supply Voltages: 24Vdc; 115Vac; 230Vac

Stage switching: DC units: negative or positive
AC units: common supply line

Strobe Beacon:

Energy: 5 Joules (5Ws)

Flash rates: Option 1: 1Hz (60 fpm)
Option 2: 1.5Hz (90 fpm)
Option 3: Double Strike

Peak Candela: 500,000 cd - calculated from energy (J)

Effective Intensity: 250 cd - calculated from energy (J)

Peak Candela: 46,976 cd* - measured ref. to I.E.S.

Effective Intensity: 143 cd* - measured ref. to I.E.S.

Lens colours: Amber, Blue, Clear, Green, Magenta, Red & Yellow

Tube life : Emissions are reduced to 70% after 5 million flashes

General:

Ingress protection: EN60529: IP66
UL50E / NEMA250: 4 / 4X / 3R / 13

Enclosure material: Marine grade aluminium LM6-copper free
Chromated & powder coated - corrosion proof

Colour: Red (RAL3000), Grey (RAL7038)

Cable entries: 1 x 1/2"NPT & 2 x M20 x 1.5mm
1 x 1/2"NPT & 2 x 1/2"NPT
1 x 1/2"NPT & 2 x 3/4"NPT

Terminals: 0.5 - 2.5mm² (20-14 AWG)

Grounding stud: M5

Operating temp: 24Vdc & 115Vac: -40° to +70°C [-40° to +158°F]
230Vac: -40° to +55°C [-40° to +131°F]

Part Codes

Version: _____ Part code: _____

Product type: D1xC2X05

Horn type: R Omni-directional radial horn

Voltage: DC024 20-28V dc
AC115 110-120V ac
AC230 220-240V ac

Cable Entry Type: A 1 x 1/2"NPT & 2 x M20 x 1.5mm
[e] B 1 x 1/2"NPT & 2 x 1/2"NPT
C 1 x 1/2"NPT & 2 x 3/4"NPT

Adaptor/Stopping B Brass
plug material: [m] N Nickel Plated
S Stainless Steel

Bracket/Guard 1 A2 304 Stainless Steel
matl & tag: [s] 2 A4 316 Stainless Steel
3 A2 304 St/St with Equip. Tag
4 A4 316 St/St with Equip. Tag

Product version: [v] A1 Gas environments Class I/Zone1
D1 Dust environments Class II/Zone 20

Enclosure colour: G Grey RAL7038
[x] R Red RAL3000

Lens colour: [y] A, B, C, G Amber, Blue, Clear, Green
M, R, Y Magenta, Red, Yellow

Accessories: SP65-0001-A2 Pole Mount Bracket Kit 2" St/St A2 (304)
SP65-0001-A4 Pole Mount Bracket Kit 2" St/St A4 (316)
SP65-0003-A2 Sunshade - St/St A2 (304)
SP65-0003-A4 Sunshade - St/St A4 (316)

Current Consumption

Voltage:	Range:	Alarm Horn	Xenon Strobe	Combined
24V dc	20-28Vdc	923mA	322mA	1245mA
115V ac	110-120Vac 50/60Hz	267mA	129mA	396mA
230V ac	220-240Vac 50/60Hz	159mA	79mA	238mA

Tone table

S 1	Description	S 2	S 3	S 4	S 1	Description	S 2	S 3	S 4
T2	1200/500 @ 1Hz Sweeping DIN/PFEER P.T.A.P.	Any	T3	T44	T34	800 @ 2Hz (0.25s on, 0.25s off) IMO code 3.a ...	Any	T24	T8
T3	1000 @ 0.5Hz (1s on, 1s off) Intermittent PFE...	Any	T2	T44	T35	1000 @ 1Hz (0.50s on, 0.50s off) Intermittent	Any	T24	T8
T4	1.4KH-1.6KHz 1s, 1.6KHz-1.4KHz 0.5s NF C 48-265	Any	T24	T1	T36	2400 @ 1Hz (0.50s on, 0.50s off) Intermittent	Any	T24	T8
T5	544(100mS)/440 (400mS) NF S 32-001	Any	T19	T1	T37	2900 @ 5Hz (0.10s on, 0.10s off) Intermittent	Any	T24	T8
T6	1500/500 - (0.5s on , 0.5s off) x3 + 1s gap A...	Any	T44	T1	T38	363/518 @ 1Hz (0.50s/0.50s) Alternating	Any	T8	T19
T7	500-1500Hz Sweeping 2 sec on 1 sec off AS4428	Any	T44	T1	T39	450/500 @ 2Hz (0.25s/0.25s) Alternating	Any	T8	T19
T8	500/1200Hz @ 0.26Hz(3.3s on, 0.5s off) NEN 2575	Any	T24	T35	T40	554/440 @ 1Hz (0.50s/0.50s) Alternating	Any	T24	T19
T9	1000 (1s on, 1s off)x7 + (7s on, 1s off) IMO ...	Any	T34	T1	T41	554/440 @ 0.65Hz (0.76s/0.76s) Alternating	Any	T8	T19
T10	1000 (1s on, 1s off)x7 + (7s on, 1s off) IMO ...	Any	T34	T1	T42	561/760 @ 0.83Hz (0.60s/0.60s) Alternating	Any	T8	T19
T11	420(0.5s on, 0.5s off)x3 + 1s gap ISO 8201 Te...	Any	T1	T8	T43	780/600 @ 0.96Hz (0.52s/0.52s) Alternating	Any	T8	T19
T12	1000(0.5s on, 0.5s off)x3 + 1s gap ISO 8201 T...	Any	T1	T8	T44	800/1000 @ 2Hz (0.25s/0.25s) Alternating	Any	T24	T19
T13	422/775 (0.85 on, 0.5 off) x3 + 1s gap NFPA T...	Any	T1	T8	T45	970/800 @ 2Hz (0.25s/0.25s) Alternating	Any	T8	T19
T14	1000/2000 @ 1Hz - Singapore	Any	T3	T35	T46	800/1000 @ 0.875Hz (0.57s/0.57s) Alternating	Any	T24	T19
T15	300 Continuous	Any	T24	T35	T47	2400/2900 @ 2Hz (0.25s/0.25s) Alternating	Any	T24	T19
T16	440 Continuous	Any	T24	T35	T48	500/1200 @ 0.3Hz (1.67s/1.67s) Sweeping	Any	T24	T12
T17	470 Continuous	Any	T24	T35	T49	560/1055 @ 0.18Hz (2.73s/2.73s) Sweeping	Any	T24	T12
T18	500 Continuous IMO code 2 (Low)	Any	T24	T35	T50	560/1055 @ 3.3Hz (0.15s/0.15s) Sweeping	Any	T24	T12
T19	554 Continuous	Any	T24	T35	T51	600/1250 @ 0.125Hz (4s/4s) Sweeping	Any	T24	T12
T20	660 Continuous	Any	T24	T35	T52	660/1200 @ 1Hz (0.50s/0.50s) Sweeping	Any	T24	T12
T21	800 Continuous IMO code 2 (High)	Any	T24	T35	T53	800/1000 @ 1Hz (0.50s/0.50s) Sweeping	Any	T24	T12
T22	1200 Continuous	Any	T24	T35	T54	800/1000 @ 7Hz (0.07s/0.07s) Sweeping	Any	T24	T12
T23	2000 Continuous	Any	T3	T35	T55	800/1000 @ 50Hz (0.01s/0.01s) Sweeping	Any	T24	T12
T24	2400 Continuous	Any	T20	T35	T56	2400/2900 @ 7Hz (0.07s/0.07s) Sweeping	Any	T24	T12
T25	440 @ 0.83Hz (0.60s on, 0.60s off) Intermittent	Any	T44	T8	T57	2400/2900 @ 1Hz (0.50s/0.50s) Sweeping	Any	T24	T12
T26	470 @ 0.9Hz (0.55s on, 0.55s off) Intermittent	Any	T44	T8	T58	2400/2900 @ 50Hz (0.01s/0.01s) Sweeping	Any	T24	T12
T27	470 @ 5Hz (0.10s on, 0.10s off) Intermittent	Any	T44	T8	T59	2500/3000 @ 2Hz (0.25s/0.25s) Sweeping	Any	T24	T12
T28	544 @ 1.14Hz (0.43s on, 0.44s off) Intermittent	Any	T24	T8	T60	2500/3000 @ 7.7Hz (0.65s/0.65s) Sweeping	Any	T24	T12
T29	655 @ 0.875Hz (0.57s on, 0.57s off) Intermittent	Any	T44	T8	T61	800Hz Motor Siren	Any	T24	T12
T30	660 @ 0.28Hz (1.80s on, 1.80s off) Intermittent	Any	T24	T8	T62	1200Hz Motor Siren	Any	T24	T12
T31	660 @ 3.3Hz (0.15s on, 0.15s off) Intermittent	Any	T24	T8	T63	2400Hz Motor Siren	Any	T24	T12
T32	745 @ 1Hz (0.50s on, 0.50s off) Intermittent	Any	T24	T8	T64	Simulated Bell	Any	T21	T12
T33	800 (0.25s on, 1.00s off) Intermittent	Any	T24	T8					