

# Quickstart Guide

## GDS-IR / LPI Infrared Sensor with Loop-powered Indicator



### INSTALLATION

**IMPORTANT** - Before installing the GDS-IR / LPI, make sure there are no toxic or combustible gases are present.

Factors such as air movement, prevailing winds, convection, gas density and emission sources should be taken into account when determining sensor location. As with all sensors, the GDS-IR / LPI should be protected from falling or directed water, snow, shock, vibration and dirt.

The GDS-IR / LPI sensor may be mounted horizontally or vertically (preferred). If horizontal, make sure the GDS-IR is protected from dripping water. The Loop Powered Indicator LCD can be rotated 90 degrees by opening the display cover, pulling firmly on the display electronics, rotating the display and re-installing (see Fig 2).

Use conduit and installation practices approved for the appropriate area classification. When installed correctly, the GDS-IR / LPI is suitable for use in areas rated Class 1, Div 1, Groups B, C & D.

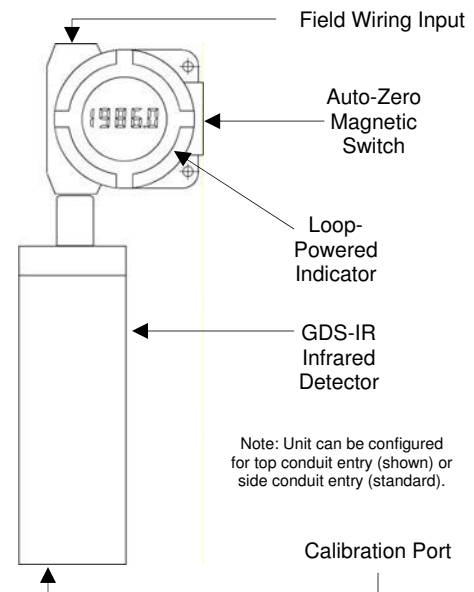

Fig 1. GDS-IR / LPI

### POWER & 4-20mA WIRING

Unscrew the cover from the LPI junction box. Firmly grasp the display module and pull forward. The display module should readily pop free from the mounting posts (see Figure 2).

**NOTE: It is NOT necessary to remove any screws to disassemble the Loop Powered Indicator**

Connect the +DC power wire to TB1-1. Connect the DC power common to TB1-2. The allowable DC voltage is +18 to +30 VDC (See Figure 3).

The GDS-IR 4-20mA output signal is available at TB1-5. Terminals 3 and 4 should remain shorted on the field wiring side .

**NOTE:** The GDS-54 Loop Powered Indicator is wired to TB1 via a 'plug-in' two position terminal strip. The terminal strip may contain an optional built-in bypass zener diode that allows the display module to be removed from the circuit without interrupting the primary 4-20mA current loop.

**NOTE:** The GDS-54 Loop Powered Indicator does *not* provide calibration capability for the GDS-IR 4-20mA output. If calibration, adjustment, alarm relays or MODBUS® serial interface is required, see the GDS Corp GASMAX II / GDS-IR gas monitor.

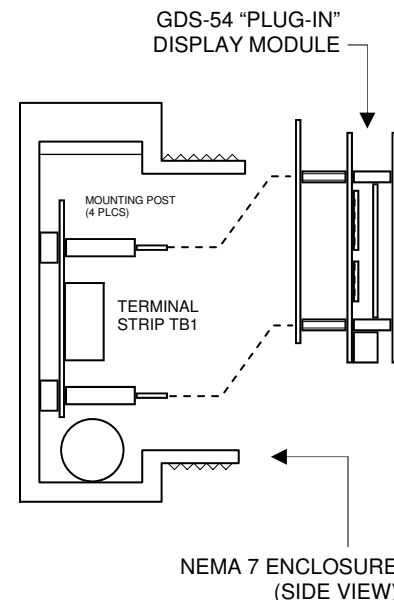

Fig 2. Loop Powered Indicator Module

AUTHORIZED DISTRIBUTOR - GasDetectorsUSA.com - Houston, Texas USA

[sales@GasDetectorsUSA.com](mailto:sales@GasDetectorsUSA.com) - 832-615-3588

## INITIAL STARTUP & AUTO ZERO

Apply power to the GDS-IR / LPI and allow the instrument to stabilize for at least one (1) hour.

**IMPORTANT - Ensure there is no combustible gas present during the auto-zero procedure. Apply a flow of nitrogen or known 'zero air' if necessary. Setting zero with background target gas will cause erroneous readings.**

Using a magnetic wand, activate the auto-zero switch located behind the RED conduit end-cap on the Loop Powered Display enclosure. Hold the wand in place for at least 10 seconds, but not more than 20 seconds. The GDS-IR should momentarily output 2.2mA to indicate a successful auto-zero. The LPI numeric display may dim or disappear momentarily.

Adjust the ZERO setting on the LPI until the display reads "00.0".

Apply a 0.5 to 1.0 LPM flow of 50% LEL methane calibration gas to the GDS-IR via the 1/4" inlet located on the bottom of the instrument. When stabilized, adjust the SPAN setting on the LPI to read "50.0".

Remove the calibration gas and recheck for zero. The instrument is now ready for operation.

## OPERATION

During normal operation\*, the output of the GDS-IR current loop continuously indicates the concentration of combustible hydrocarbon gas present in the ambient atmosphere. In the event of instrument malfunctions or calibration activities, the output current value can be used to determine status as shown:

0.0mA	Instrument Fault	2.2mA	Unit Zeroing
0.2mA	Ref Channel Fault	4.0mA	Zero Gas
0.4mA	Analytic Ch Fault	5.6mA	10% LEL*
0.8mA	Unit Warm-Up	8.0mA	25% LEL*
1.0mA	Optics Fault	12mA	50% LEL*
1.2mA	Zero Drift Fault	16mA	75% LEL*
1.6mA	Calibration Fault	20mA	100% LEL*
2.0mA	Unit Spanning	20 - 23mA	Over-range

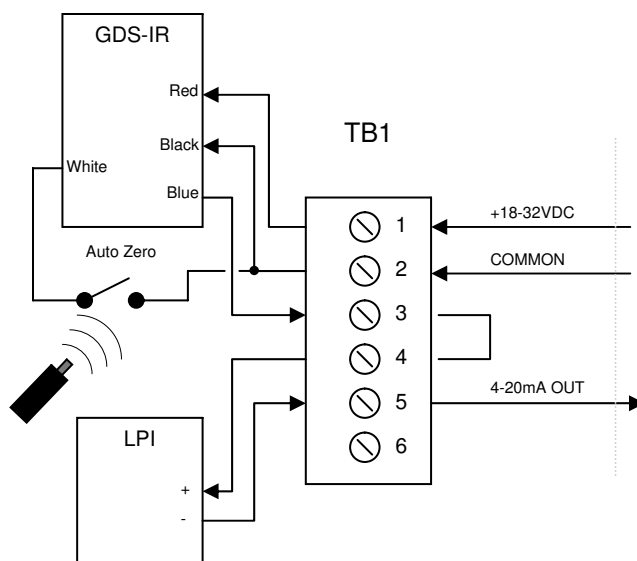

Fig 3. GDS-IR / LPI FIELD WIRING

**Note:** The Loop Powered Indicator will NOT operate unless the 4-20mA current loop output (TB1-5) is connected to COMMON at the receiving instrument input

## CLEANING

To inspect or clean the optics path, unscrew the barrel of the GDS-IR. Remove the slotted setscrew and hydroscopic filter. Loosen the small hex setscrew on the center assembly and remove the assembly by rotating the long barrel CW and the top fitting CCW. Clean the upper and lower optics windows using lint-free cloth. Reassemble in reverse order.

After cleaning, always perform the auto-zero operation as described above.