



**Sensepoint XCD
Gas Detector**

1 Safety

Ensure that this Technical Manual is read and understood **BEFORE** installing / operating / maintaining the equipment. Pay particular attention to **Warnings** and **Cautions**. All document **Warnings** are listed here and repeated where appropriate at the start of the relevant chapter(s) of this Technical Manual. **Cautions** appear in the sections/sub-sections of the document where they apply.

WARNINGS

Sensepoint XCD is designed for installation and use in Zone 1 or 2 hazardous areas in many countries including Europe and for Class 1 Division 1 or 2 area applications in North America.

Installation must be in accordance with the recognized standards of the appropriate authority in the country concerned.

Access to the interior of the detector, when carrying out any work, must only be conducted by trained personnel.

Before carrying out any work ensure local regulations and site procedures are followed. Appropriate standards must be followed to maintain the overall certification of the detector.

For installations where conduit is used, and the sensor is mounted directly to the Sensepoint XCD, there must be a "Seal Fitting" installed for each of the cable gland entries within 18 inches of the Sensepoint XCD. The total distance of the location of these Seal Fittings is 18 inches. (e.g. If all 3 gland entries are to be used, 3 Seal Fittings should be located, each within 6 inches of the wiring entrance).

If using an anti-seize compound, the threads should be thinly coated with an approved silicone free compound e.g. petroleum jelly

To reduce the risk of ignition of hazardous atmosphere, de-classify the area or disconnect the equipment from the supply circuit before opening the detector enclosure. Keep assembly tightly closed during operation.

Never attempt to open a junction box/enclosure or replace/refit the sensor in potentially hazardous atmospheres while power is still applied to the transmitter.

The detector must be earthed/grounded for electrical safety and to limit the effects of radio frequency interference. Earth/ground points are provided inside and outside the unit. The internal grounding shall be used as the primary equipment ground. The external terminal is only a supplemental bonding connection where local authorities permit or require such a connection.

Ensure that all screens/instrument earth/clean earth wiring is earthed/grounded at a single point (either at the controller or detector - BUT NOT BOTH) to prevent false readings or alarms that may occur due to potential earth/ground loops.

Take care when handling sensors as they may contain corrosive solutions. Do not tamper with or in any way disassemble the sensor.

Do not expose to temperatures outside the recommended ranges.

Do not expose sensors under storage conditions to organic solvents or flammable liquids.

At the end of their working life, replacement electrochemical sensors for oxygen and toxic gas must be disposed of in an environmentally safe manner. Disposal should be according to local waste management requirements and environmental legislation. Alternatively, old replaceable sensors may be securely packaged and returned to Honeywell Analytics clearly marked for environmental disposal.

Electrochemical sensors should NOT be incinerated as this action may cause the cell to emit toxic fumes.

Refer to the local or national regulations relative to the installation at the site. For Europe see EN60079-29-2, EN60079-14 and EN61241-14.

Only assessed for ATEX for ignition hazards.

This equipment is designed and constructed as to prevent ignition sources arising, even in the event of frequent disturbances or equipment operating faults.

The sensor head must be fitted with the supplied weather protection, and mounted so that the sinter is pointing downward to provide ingress protection IPX6.

The weather protection is a potential electrostatic charging hazard. The manufacturer's instructions should be observed.

NOTE: The control card must have a suitably rated fuse.

2 Information

This manual is for use with the Sensepoint XCD range transmitters only.

The Start-up/Surge/In rush current is dependant on the type of power supply used. The typical start-up current for Sensepoint XCD is less than 800mA. Measure the start-up current using the specific power supply before installation to ensure suitability for your application.

Honeywell Analytics can take no responsibility for installation and/or use of its equipment if not done so in accordance with the appropriate issue and/or amendment of the Technical Manual.

The reader of this Technical Manual should ensure that it is appropriate in all details for the exact equipment to be installed and/or operated. If in doubt, contact Honeywell Analytics for advice.

The following types of notices are used throughout this Technical Manual:

WARNING

Identifies a hazardous or unsafe practice which could result in severe injury or death to personnel.

Caution: Identifies a hazardous or unsafe practice which could result in minor injury to personnel, or product or property damage.

Note: Identifies useful/additional information.

Every effort has been made to ensure the accuracy of this document, however, Honeywell Analytics can assume no responsibility for any errors or omissions in this document or their consequences.

Honeywell Analytics would greatly appreciate being informed of any errors or omissions that may be found in the content of this document.

For information not covered in this document, or if there is a requirement to send comments/corrections about this document, please contact Honeywell Analytics using the contact details given on the back page.

Honeywell Analytics reserve the right to change or revise the information supplied in this document without notice and without obligation to notify any person or organization of such revision or change. If information is required that does not appear in this document, contact the local distributor/agent or Honeywell Analytics.

3 Table of contents

| | |
|---|-----------|
| 1 Safety | 2 |
| 2 Information | 3 |
| 4 Introduction | 6 |
| 4.1 Transmitter..... | 7 |
| 4.2 Flammable, Toxic Oxygen Gas sensors | 7 |
| 4.3 Accessories..... | 8 |
| 4.4 Options | 10 |
| 4.4.1 Modbus® | 10 |
| 5 Installation | 12 |
| 5.1 Mounting and location..... | 13 |
| 5.2 Mounting the transmitter | 13 |
| 5.3 Installing the sensor | 15 |
| 6 Electrical connections | 16 |
| 6.1 Transmitter Wiring..... | 17 |
| 6.2 Terminal connections | 18 |
| 6.3 Power..... | 19 |
| 6.4 Cabling..... | 20 |
| 6.5 Cable and Earth/Ground regimes | 20 |
| 6.6 Ground Terminal Wiring | 21 |
| 7 Default configuration | 22 |
| 8 Normal Operation | 23 |
| 8.1 Display Screen..... | 23 |
| 8.2 System Status..... | 24 |
| 8.3 Magnetic Wand Activation..... | 25 |
| 8.4 Mode Structure | 25 |
| 9 First time switch on (Commissioning) | 26 |
| 10 Response Check and Calibration | 28 |
| 10.1 Zeroing and span calibration | 28 |
| 11 General Maintenance | 32 |
| 11.1 Operational Life..... | 32 |
| 12 Servicing | 33 |
| 12.1 Sensor replacement..... | 33 |
| 12.2 Replacing Modules within the Transmitter | 35 |
| 12.3 Faults and Warnings | 36 |
| 13 Menu's and Advanced Configuration | 37 |
| 13.1 Abort Function..... | 37 |
| 13.2 Configuration Mode | 37 |
| 13.3 Sensor / Gas Selection | 43 |
| 13.4 Review Mode | 45 |
| 14 General specification | 48 |
| 15 Ordering information | 49 |
| 16 Warranty statement | 52 |
| 17 Installation Drawing | 53 |

| | |
|--|-----------|
| 17.1 Mechanical Installation Drawing | 53 |
| 17.2 Electronic Connection Drawing..... | 54 |
| 17.3 Duct Mounting Drawing | 55 |
| 17.4 Collecting Cone Drawing | 56 |
| 17.5 Mounting Bolt Assy Drawing | 57 |
| 17.6 Mounting Bracket Drawing..... | 58 |
| 18 Certification..... | 59 |
| 18.1 China GB Ex and PA..... | 59 |
| 18.2 Korea KTL..... | 62 |
| 18.3 European ATEX | 63 |
| 18.4 International IEC | 65 |
| 18.5 Sensepoint XCD ATEX Name Plate | 67 |
| 18.6 Sensepoint XCD UL Name Plate | 68 |
| 18.7 Sensepoint XCD Warning Tag | 69 |
| 18.8 Sensor Cartridges Label..... | 71 |
| 19 Cross Interference and Cross Calibration | 72 |
| 19.1 Cross Interference Table for Toxic and Oxygen | 72 |
| 19.2 Cross Calibration Flammable Gas Detector | 73 |
| 19.3 Meter Multiplication Factors for Sensepoint XCD-IR Propane..... | 76 |

4 Introduction

The Sensepoint XCD (“Exceed”) comprises a gas detector transmitter and a choice of sensors for detecting flammable gas, toxic gas and oxygen. The construction of Sensepoint XCD allows it to be used in hazardous area locations; it may also be used in other areas not classified as hazardous.

As well as a comprehensive range of Sensepoint XCD sensors, a wide range of existing Honeywell Analytics sensors may be used with the Sensepoint XCD transmitter to detect a broader range of target gases (please contact Honeywell Analytics for further details).

The transmitter features a display and three programmable relays for controlling external equipment e.g. alarms, sirens, valves or switches. The transmitter provides an industry standard 3-wire, 4-20mA source or sink output for connection to a dedicated gas detection control system or PLC.

Calibration and maintenance is carried out using a Magnetic Wand, this allows a single user to undertake routine maintenance without needing to access internal components. Sensepoint XCD is suitable for use in Zone 1 or 2 hazardous areas (International) or Class I Division 1 or 2 area applications (North America).

Sensepoint XCD comprises of the main parts as shown below.

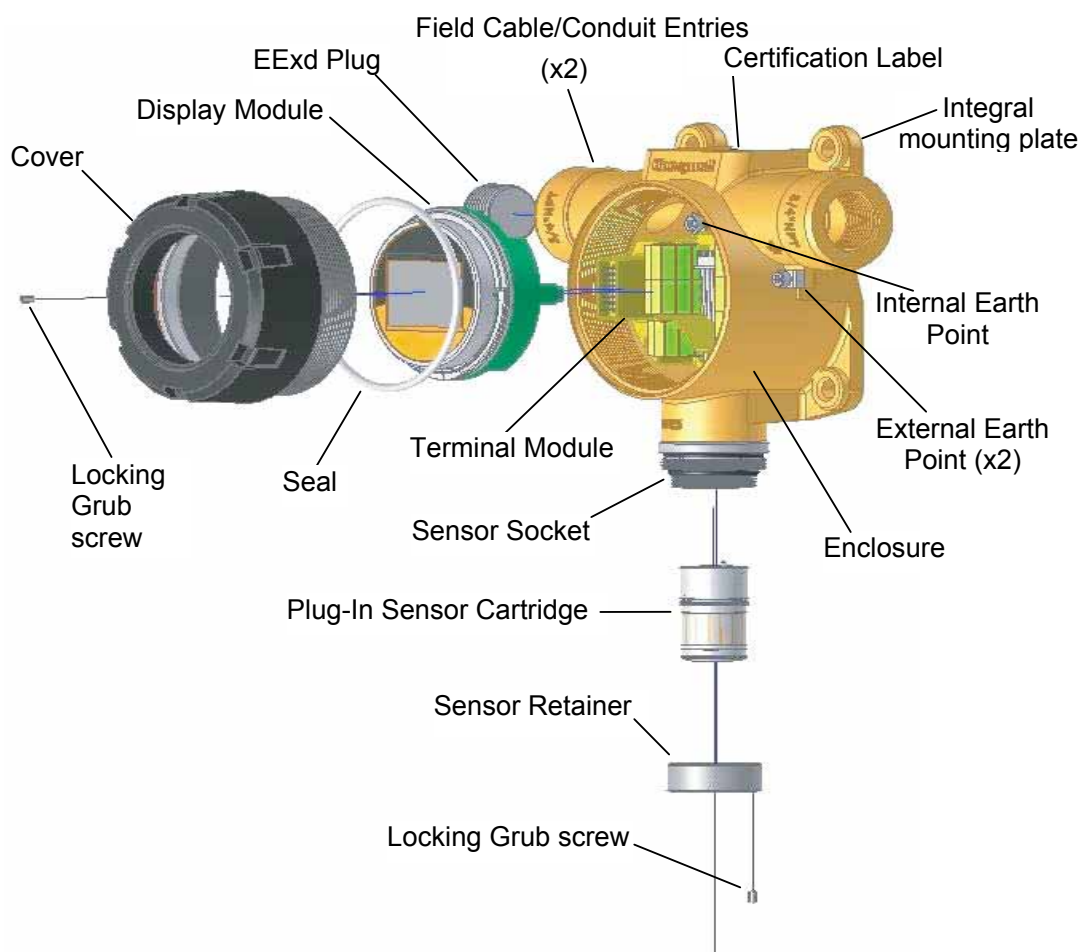

Diagram 1. – Exploded View

4.1 Transmitter

The transmitter enclosure has three threaded entries. The two cable/conduit entries either side of the upper part of the transmitter housing are for connecting the power source, signal output and relay contacts to associated signalling equipment. The bottom entry allows direct connection of the sensor socket. There is a mounting plate incorporated into the transmitter housing allowing for various mounting configuration options.

A local LCD provides gas type, concentration, alarm and operating status. The display provides numerical, bar graph and icon information.

Diagnostic information may also be displayed when the transmitter is interrogated using a magnet. The transmitter cover has a glass window which allows use of the Magnetic Wand to activate the three user interface magnetic switches that are located on the front of the display module. The magnet also enables a non intrusive, one-man calibration and configuration facility for the Sensepoint XCD.

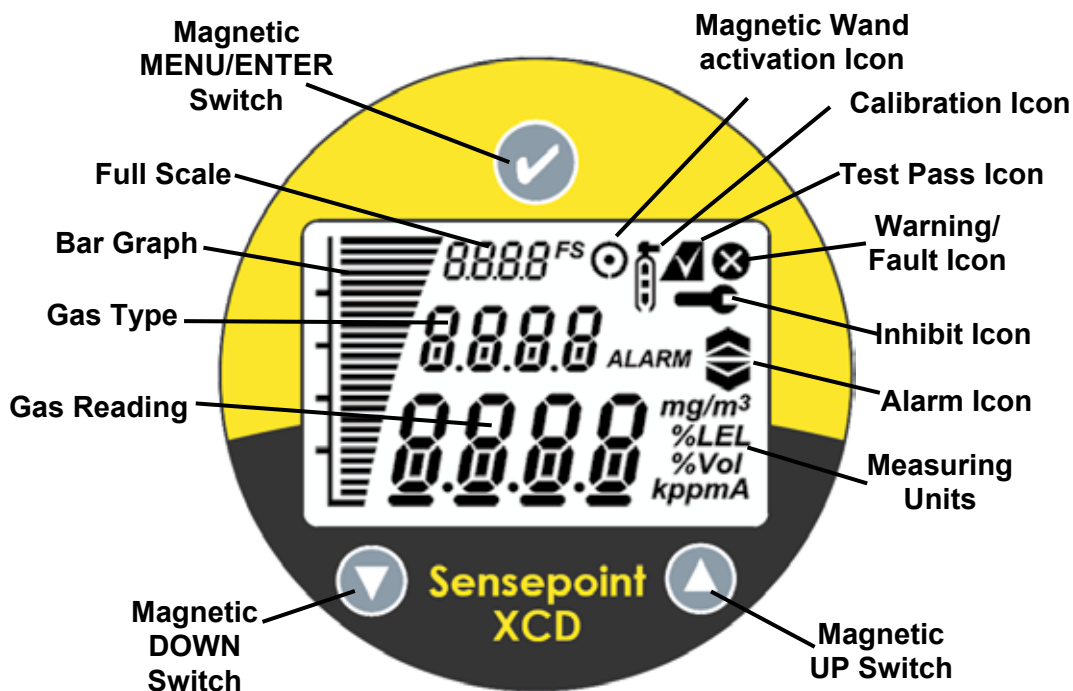

Diagram 2: Sensepoint XCD Display and Magnetic Switches

4.2 Flammable, Toxic Oxygen Gas sensors

The Sensepoint XCD transmitter is designed to work with a variety of gas sensors for detecting flammable gases. Sensepoint XCD sensors use NDIR infrared and electro-catalytic technologies.

In addition, the Sensepoint XCD transmitter is designed to work with a wide range of toxic gas sensors. Sensepoint XCD sensors for monitoring toxic gas oxygen use electro-chemical cell (ECC) technology.

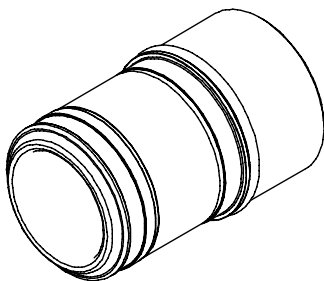
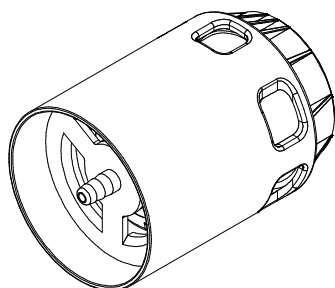

Diagram 3: Sensepoint XCD Flammable, Toxic and Oxygen Sensor Cartridge

4.3 Accessories

A range of accessories are available to allow use of Sensepoint XCD in a wide variety of applications. These including mounting brackets, maintenance tools, weather housings, flow housing, collecting cone, duct mounting kit and sensor junction boxes.



Standard Weather Protection

The Standard Weather Protection (P/N: SPXCDWP) is designed to protect the sensor from changes in environmental conditions. This is recommended to be fitted to a Sensepoint XCD sensor for outdoor exposed applications, (supplied with XCD kit).

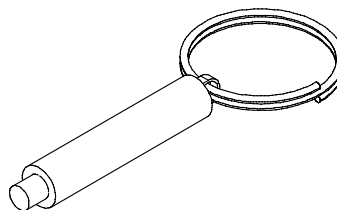

Magnetic wand

The magnetic wand (P/N: SPXCDMAG) is used as a tool to allow the user to communicate with the Sensepoint XCD transmitter for the purpose of configuration, calibration and interrogating system status, (supplied with XCD kit).

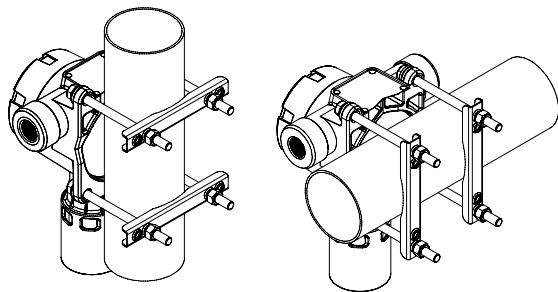

Pipe mounting bracket

The Pipe Mounting Bracket (P/N: SPXCMTBR) is an optional accessory and may be used to allow the Sensepoint XCD to be installed onto a dedicated mounting post or existing structure at the desired location.

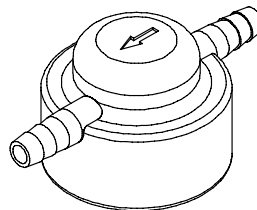

Gassing Cap

The Gassing Cap (P/N: S3KCAL) is an optional accessory that may be temporarily fitted to the sensor in place of the Weather Protection for Gas Response checking during commissioning and routine maintenance.

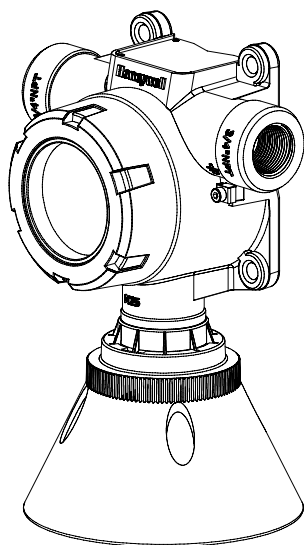

Collecting cone

The Collecting Cone (P/N: SPXCDC) is an optional accessory that may be fitted to the Weather Protection. The collecting cone is designed for use with lighter than air.

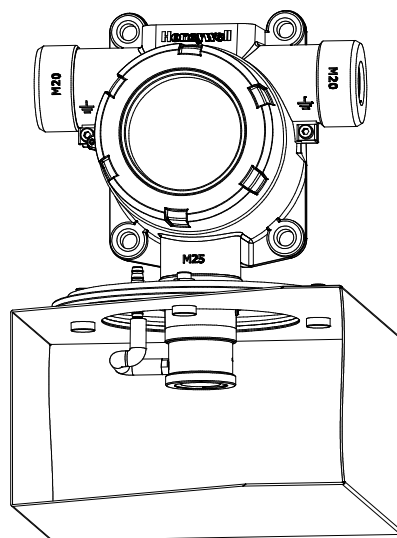

Duct mounting kit

The Duct Mounting Kit (P/N: SPXCDDMK) is an optional accessory that is designed for applications to allow the monitoring for the presence of gas inside a Heating, Ventilation or Air Conditioning (HVAC) duct is required.

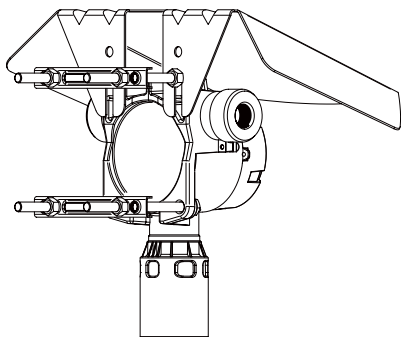

Sunshade Deluge Cover

The XCD Sunshade Deluge Cover (P/N: SPXCSDP) is an optional accessory that may be fitted to the integral mounting plate. This accessory is designed to protect XCD from overheating in exposed hot and arid climates, particularly offering additional protection from thermal shock in Tropical Environments

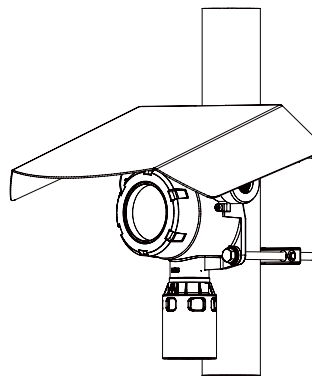

Typical Mounting Arrangement

4.4 Options

4.4.1 Modbus®

One of the most common field buses in the industry, the optional Modbus® interface allows the XCD to connect to a bus of devices and transmit data to PLCs or controllers (see Appendix A). Connections to the XCD are made through a pluggable terminal block on the Modbus® interface circuit board. Modbus® RTU protocol uses ASCII/Hex protocols for communication, and allows all transmitter/sensor front panel functions to be transmitted using this industrial fieldbus.

Modbus® protocol is a Master-Slaves protocol. Only one master (at the same time) is connected to the bus and one or up to 32 slave nodes are also connected to the same serial bus. Modbus® communication is always initiated by the master. The slave nodes will never transmit data without receiving a request from the master node. The slave nodes will never communicate with each other. The master node initiates only one Modbus® transaction at the same time.

Modbus option is available only for selected gases. Please refer to chapter 15 Ordering information.

To find out if a unit has the ModBus option fitted, look at the part number on the product label. Units fitted with ModBus have the letter “M” at the end of the part number.

Note: MODBUS® is a registered trademark of Schneider Automation Inc.

(MODBUS ID SETTING)

Set id>>Set ModBus slave ID>>Set Baud rate>>Set Parity

- 1) Slave ID shall be set 1~247
- 2) Baud rate setting 9600 or 19200
- 3) Parity setting (No, Even, Odd)

From the Configuration Mode screen, select '✓'. To set the ModBus Slave ID, use the up-down '▲▼' switches to move to the desired position and use '✓' to select it. Again, using the '▲▼' switches, increment or decrement the value until the desired value appears, selects the value and moves to the next setting.

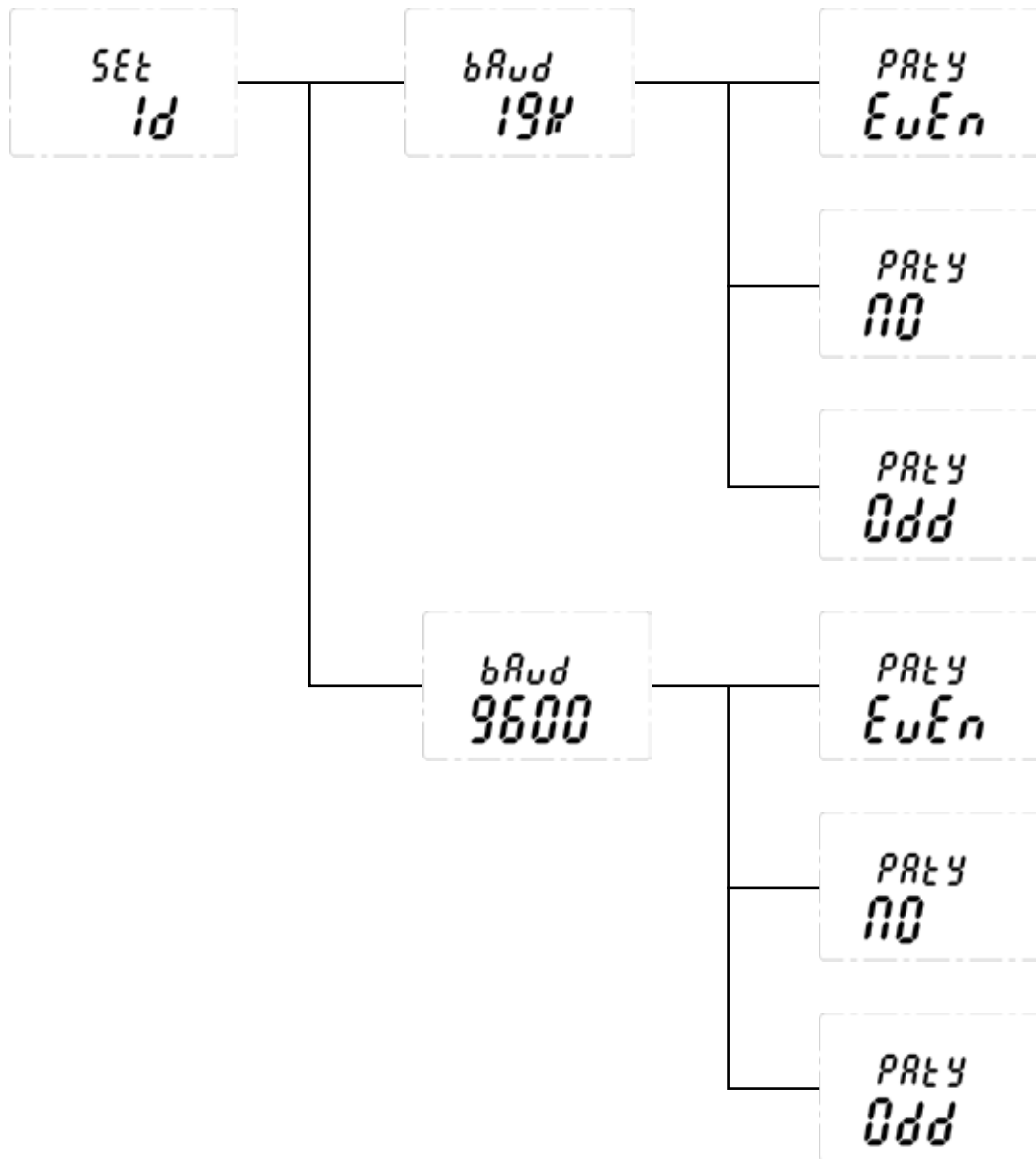

The communications baud rate and Parity Setting can also be set from this screen by using the '▲▼' switches to navigate to the baud rate display then selecting '✓'. Using the '▲▼' switches, highlight the proper baud rate or parity setting and select '✓'. Default is Slave ID 1, 19200bps and even parity.

Note: Set ID menu is available only for XCD equipped with Modbus option.

5 Installation

WARNINGS

Sensepoint XCD is designed for installation and use in Zone 1 or 2 hazardous areas in many countries including Europe and for Class 1 Division 1 or 2 area applications in North America.

Installation must be in accordance with the recognized standards of the appropriate authority in the country concerned.

Access to the interior of the detector, when carrying out any work, must only be conducted by trained personnel.

Before carrying out any work ensure local regulations and site procedures are followed. Appropriate standards must be followed to maintain the overall certification of the detector.

Care should be taken when removing and refitting the Sensepoint XCD plug-in Sensor to the Sensor Socket so that damage to the connection pins can be avoided.

For installations where conduit is used, and the sensor is mounted directly to the Sensepoint XCD, there must be a "Seal Fitting" installed for each of the cable gland entries within 18 inches of the Sensepoint XCD. For installations where the sensor will be mounted remotely from Sensepoint XCD, an additional "Seal Fittings" will be required: One at each of the conduit entries for the power/signal/relay contact outputs and one at the sensor wiring entrance. The total distance of the location of these Seal Fittings is 18 inches. (e.g. If all 3 gland entries are to be used, 3 Seal Fittings should be located, each within 6 inches of the wiring entrance).

If using an anti-seize compound, the threads should be thinly coated with an approved silicone free compound e.g. petroleum jelly

To reduce the risk of ignition of hazardous atmosphere, de-classify the area or disconnect the equipment from the supply circuit before opening the detector enclosure. Keep assembly tightly closed during operation.

Never attempt to open a junction box/enclosure or replace/refit the sensor in potentially hazardous atmospheres while power is still applied to the transmitter.

The detector must be earthed/grounded for electrical safety and to limit the effects of radio frequency interference. Earth/ground points are provided inside and outside the unit. Ensure that all screens/instrument earth/clean earth wiring is earthed/grounded at a single point (either at the controller or detector - BUT NOT BOTH) to prevent false alarms due to earth/ground loops.

Take care when handling sensors as they may contain corrosive solutions.

Do not tamper with or in any way disassemble the sensor.

Do not expose to temperatures outside the recommended ranges.

Do not expose sensors under storage conditions to organic solvents or flammable liquids.

At the end of their working life, replacement electrochemical sensors for oxygen and toxic gas must be disposed of in an environmentally safe manner. Disposal should be according to local waste management requirements and environmental legislation.

Alternatively, old replaceable sensors may be securely packaged and returned to Honeywell Analytics clearly marked for environmental disposal.

Electrochemical sensors should NOT be incinerated as this action may cause the cell to emit toxic fumes.

Refer to the local or national regulations relative to the installation at the site. For Europe see EN60079-29-2, EN60079-14 and EN61241-14.

Only assessed for ATEX for ignition hazards.

This equipment is designed and constructed as to prevent ignition sources arising, even in the event of frequent disturbances or equipment operating faults.

The sensor head must be fitted with the supplied weather protection, and mounted so that the sinter is pointing downward to provide ingress protection IPX6.

The weather protection is a potential electrostatic charging hazard. The manufacturer's instructions should be observed.

NOTE: The control card must have a suitably rated fuse.

5.1 Mounting and location

Caution: The location of gas detectors should be made in accordance with any relevant local and national legislation, standards or codes of practice. Always replace sensors with a sensor of the same type.

Gas detectors should be mounted where a potential hazard of gas is most likely to be present. The following points should be noted when locating gas sensors.

- When locating detectors consider the possible damage caused by natural events e.g. rain or flooding.
- Consider ease of access to the gas detector for functional testing and servicing.
- Consider how escaping gas may behave due to natural or forced air currents.

Note: The placement of gas detectors should be determined following the advice of experts having specialist knowledge of gas dispersion, experts having knowledge of the process plant system and equipment involved, safety and engineering personnel. The agreement reached on the location of detectors should be recorded.

5.2 Mounting the transmitter

The Sensepoint XCD transmitter has an integral mounting plate consisting of four mounting holes on the transmitter body. The transmitter may be fixed directly to a surface mounting, or to a horizontal or vertical pipe/structure, 40.0-80.0mm (1.6 to 3.1 inches) in diameter/cross section. The Pipe Mounting Bracket accessory (optional accessory) may be used for this purpose.

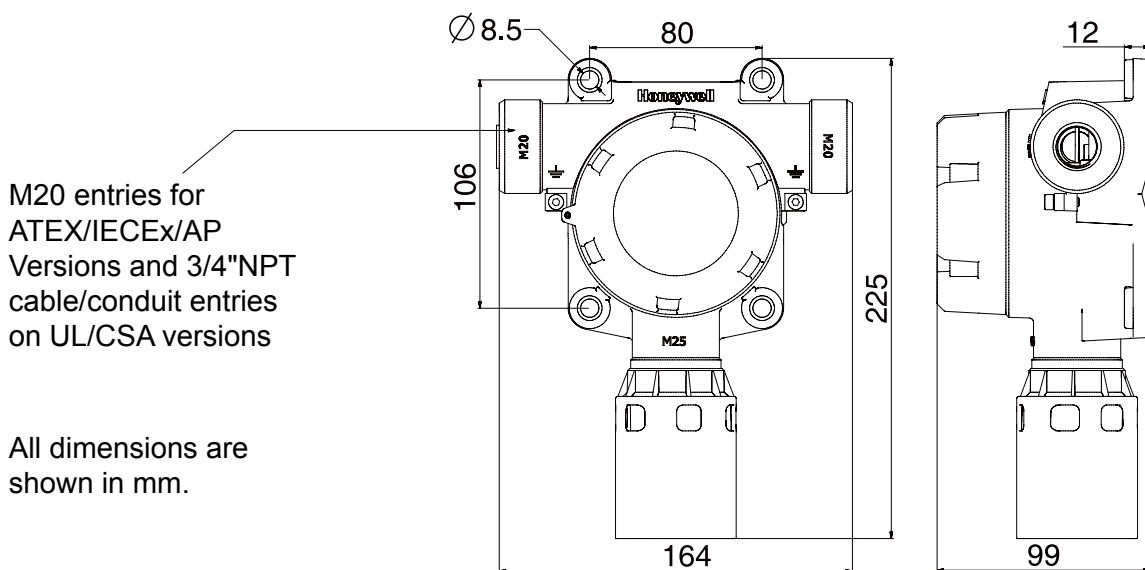

Diagram 4: Outline and mounting dimensions

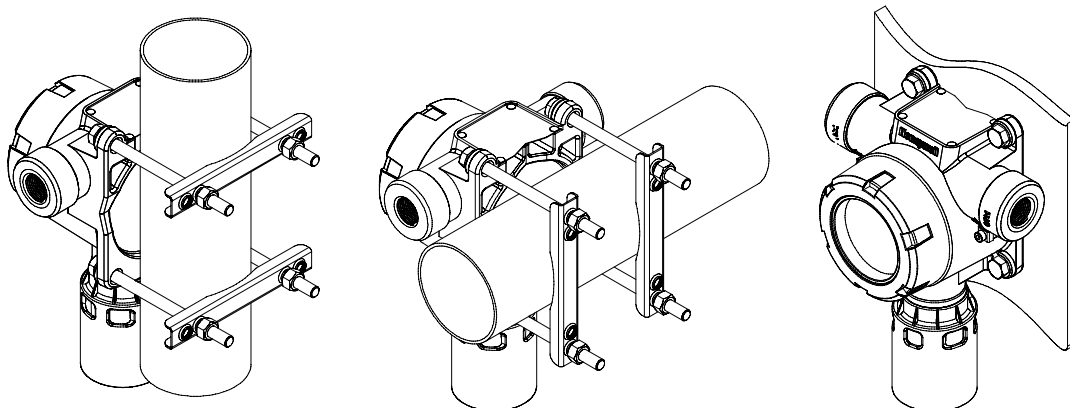

Diagram 5: Mounting arrangements

To mount the Sensepoint XCD transmitter to a Vertical or Horizontal pipe/structure, use the optional XCD Mounting Kit and following procedure:

1. Fit the four spring washers, then the plain washers to the M8 x 80mm SS316 bolts.
2. Pass the four bolts through the four mounting holes of the transmitter housing.
3. **Note:** If the XCD sunshade is to be used then fit the sunshade and the two locking bolts and washers to the M8 x 80 bolts.
4. Place the transmitter housing against the mounting position and fit the two “U” channel mounting bars the other side of the Pipe/Structure.
5. Secure bolts to the threaded holes of the “U” channel mounting bars.
6. Tighten the four bolts securely, (but do not over-tighten) until the transmitter housing cannot be moved by hand on its mounting position.

Note: For further details of installation please see section 17.

5.3 Installing the sensor

The XCD gas sensor cartridge plugs into the XCD Sensor Socket.

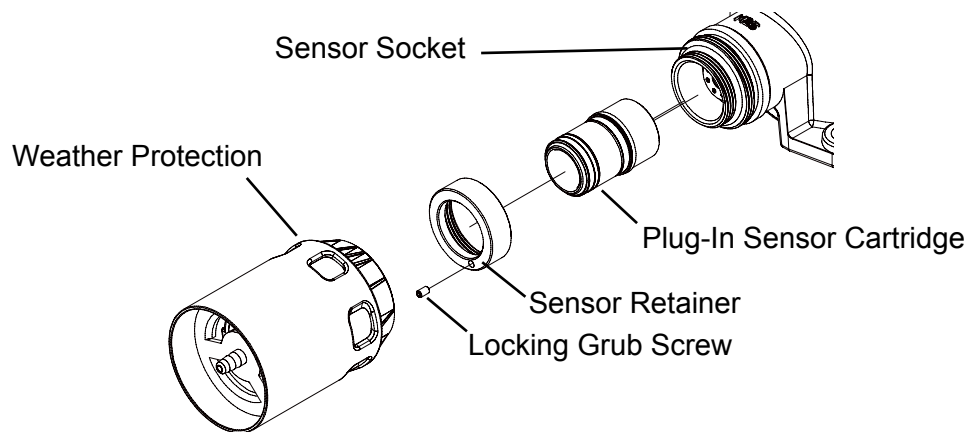

Diagram 6: Installing the Sensor

WARNINGS

Care should be taken when removing and refitting the Sensepoint XCD plug-in Sensor to the Sensor Socket so that damage to the connection pins can be avoided.

If using an anti-seize compound, the threads should be thinly coated with an approved silicone free compound e.g. petroleum jelly

Take care when handling old sensors as they may contain corrosive solutions.

Take care when removing or replacing the Sensor Retainer as there may be sharp edges present on the adjoining threads.

The equipment is designed and constructed as to prevent ignition sources arising, even in the event of frequent disturbances or equipment operating faults.

Only assessed for ATEX for ignition hazards.

The sensor head must be fitted with the supplied weather protection, and mounted so that the sinter is pointing downward to provide ingress protection IPX6.

The weather protection is a potential electrostatic charging hazard. The manufacturer's instructions should be observed.

To install the XCD Sensor Cartridge to the XCD Sensor Socket:

1. Remove the weather protection (if fitted) from the sensor.
2. Use a 1.5mm Allen key (hexagonal wrench-included) to loosen the Locking Grub Screw on the Sensor Retainer.
3. Unscrew and remove the Sensor Retainer.
4. Remove the XCD Sensor Cartridge from its packaging and plug it into the XCD Sensor Socket, taking care to align the sensor pins with the connector.
5. Refit the Sensor Retainer and tighten the Locking Grub Screw.
6. Refit the weather protection (as required) to the XCD sensor.

6 Electrical connections

WARNINGS

Sensepoint XCD is designed for installation and use in Zone 1 or 2 hazardous areas in many countries including Europe and Class 1 Division 1 or 2 area applications in North America.

Installation must be in accordance with the recognized standards of the appropriate authority in the country concerned.

Access to the interior of the detector, when carrying out any work, must only be conducted by trained personnel.

Before carrying out any work ensure local regulations and site procedures are followed. Appropriate standards must be followed to maintain the overall certification of the detector.

Care should be taken when removing and refitting the Sensepoint XCD Sensor Cartridge to the Sensor Socket so that damage to the connection pins can be avoided.

For installations where conduit is used, and the sensor is mounted directly to the Sensepoint XCD, there must be a "Seal Fitting" installed for each of the cable gland entries within 18 inches of the Sensepoint XCD. The total distance of the location of these Seal Fittings is 18 inches. (e.g. If all 3 gland entries are to be used, 3 Seal Fittings should be located, each within 6 inches of the wiring entrance).

If using an anti-seize compound, the threads should be thinly coated with an approved silicone free compound e.g. petroleum jelly

To reduce the risk of ignition of hazardous atmosphere, de-classify the area or disconnect the equipment from the supply circuit before opening the detector enclosure. Keep assembly tightly closed during operation.

Never attempt to open a junction box/enclosure or replace/refit the sensor in potentially hazardous atmospheres while power is still applied to the transmitter.

The detector must be earthed/grounded for electrical safety and to limit the effects of radio frequency interference. Earth/ground points are provided inside and outside the unit. Ensure that all screens/instrument earth/clean earth wiring is earthed/grounded at a single point (either at the controller or detector - BUT NOT BOTH) to prevent false alarms due to earth/ground loops.

Take care when handling sensors as they may contain corrosive solutions.

Do not tamper with or in any way disassemble the sensor.

Do not expose to temperatures outside the recommended ranges.

Do not expose sensors under storage conditions to organic solvents or flammable liquids.

At the end of their working life, replacement electrochemical sensors for oxygen and toxic gas must be disposed of in an environmentally safe manner. Disposal should be according to local waste management requirements and environmental legislation.

Alternatively, old replaceable sensors may be securely packaged and returned to Honeywell Analytics clearly marked for environmental disposal.

Electrochemical sensors should NOT be incinerated as this action may cause the cell to emit toxic fumes.

Refer to the local or national regulations relative to the installation at the site. For Europe see EN60079-29-2, EN60079-14 and EN61241-14.

6.1 Transmitter Wiring

Caution: All electrical connections should be made in accordance with any relevant local or national legislation, standards or codes of practice.

The Sensepoint XCD transmitter may be wired in either Current SOURCE or Current SINK configuration. These two options are offered to allow greater flexibility in the type of control system that it can be used with. SOURCE/SINK is selectable via the switch located on the back side of the display module; accessible by removing the display module during installation / commissioning (see section 9).

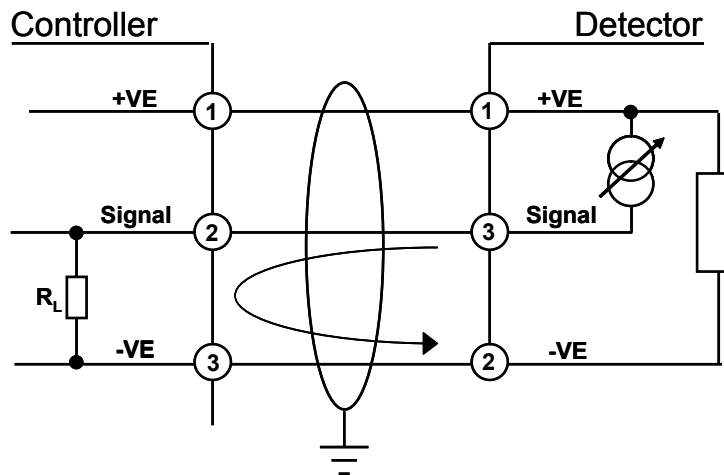

XCD Source 3 Wire 4-20mA (Source)

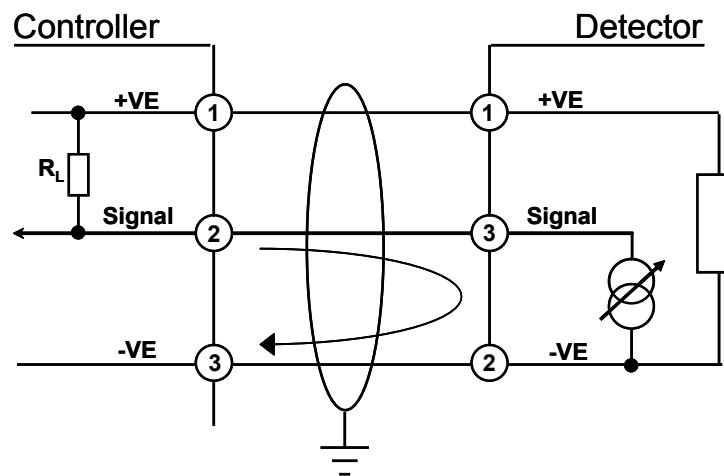

XCD Sink 3 Wire 4-20mA (Sink)

*Note: Terminate cable screen at detector or controller, not both.
250ohm load resistor (R_L) is installed in the factory, In case of connection with controller, this resistor should be removed because controller has load resistor internally.*

6.2 Terminal connections

Note: Ensure that none of the wires in the terminal area cause an obstruction when refitting the Display Module. Ensure that the socket on the Display Module is fully engaged in the Display Module Connector on the Terminal Module.

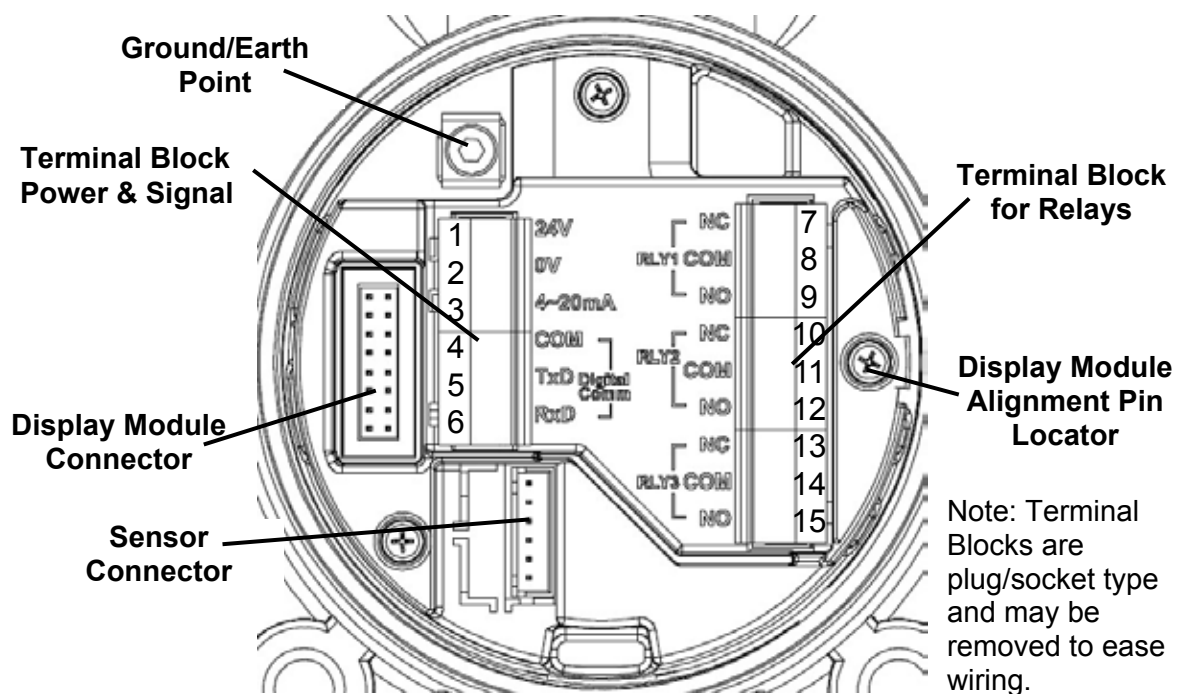

Diagram 7: Terminal module

| Terminal Module Connections | | | |
|-----------------------------|----------|-----------------------|--------------------------------------|
| Terminal Number | Marking | Connection | Description |
| 1 | 24V | +VE Supply(16-32VDC) | Controller Connections |
| 2 | 0V | -VE Supply(0VDC) | |
| 3 | 4~20mA | Current Output Signal | |
| 4 | COM | Common | MODBUS RTU. RS485 (Optional) |
| 5 | TxD | MODBUS A(+) | |
| 6 | RxD | MODBUS A(-) | |
| 7 | RLY1/NC | Normally Closed | Programmable Relay 1 (Default A1) |
| 8 | RLY1/COM | Common | |
| 9 | RLY1/NO | Normally Open | |
| 10 | RLY2/NC | Normally Closed | Programmable Relay 2 (Default A2) |
| 11 | RLY2/COM | Common | |
| 12 | RLY2/NO | Normally Open | |
| 13 | RLY3/NC | Normally Closed | Programmable Relay 3 (Default Fault) |
| 14 | RLY3/COM | Common | |
| 15 | RLY3/NO | Normally Open | |

Table 1: Transmitter terminal connections

6.3 Power

The Sensepoint XCD transmitter requires a power supply from the controller of between 16Vdc and 32Vdc. Ensure that a minimum supply of 16Vdc is measured at the sensor, taking into account the voltage drop due to cable resistance.

The maximum loop resistance in the field cable is calculated as follows:

$$R_{loop} = (V_{controller} - V_{detector\ min}) / I_{detector}$$

Example;

The controller is supplying a nominal 24Vdc ($V_{controller}$), the detector minimum allowable voltage is 16Vdc ($V_{detector\ min}$), therefore the maximum allowable voltage drop between the controller and detector is 8Vdc; this means a voltage drop of 4V in each core (+ve core and -ve core).

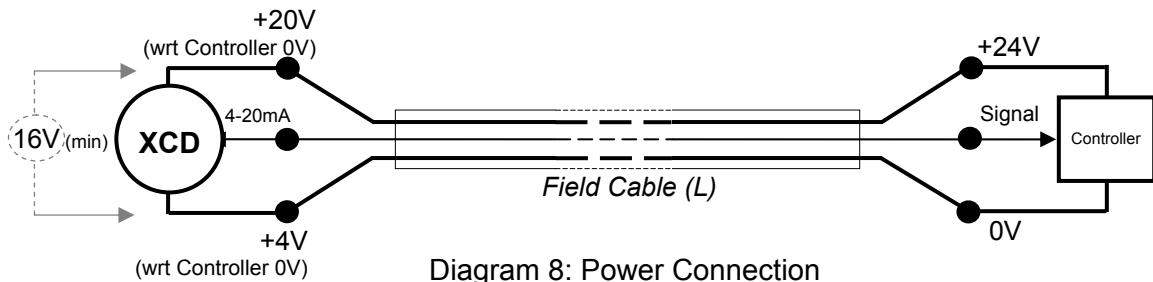

Diagram 8: Power Connection

Power consumption of the detector is 5.0W. The current required to drive the detector at the minimum voltage is ($I = P / V$), $5.0 / 16 = 312.5\text{mA}$ ($I_{detector}$).

So, the maximum field cable loop resistance (R_{loop}) = $8 / 0.31 = 26\ \text{Ohms}$, or $13\ \text{Ohms}$ per core, (allowing for component variations, losses, etc.).

The following tables show the maximum cable distances between the controller and transmitter assuming a voltage drop of 4V in each core and for different cable parameters. The tables are examples only and actual cable parameters and source power supply voltage for the application should be used to calculate the maximum cable distance allowed at the installation site.

| Typical cable data | | Maximum Cable length (L) | |
|--------------------------------------|---|--------------------------|------|
| Cable size (cross sectional area) | Cable resistance Ω/km (Ω/mi) | Meters | Feet |
| 0.5mm ² (20AWG*) | 36.8 (59.2) | 353 | 1158 |
| 1.0mm ² (17AWG*) | 19.5 (31.4) | 666 | 2185 |
| 1.5mm ² (16AWG*) | 12.7 (20.4) | 1023 | 3356 |
| 2.0mm ² (14AWG*) | 10.1 (16.3) | 1287 | 4222 |
| 2.5mm ² (13AWG*) | 8.0 (12.9) | 1621 | 5318 |
| *nearest equivalent | | | |

Table 2: Maximum cable distances

6.4 Cabling

Caution: All unused and used cable/conduit entries must be sealed with a suitable certified sealing plug and cable gland.

The use of industrial grade, suitably armoured field cable is recommended.

For example, screened 3 cores (plus screen 90% coverage), suitably mechanically protected copper cable with a suitable M20 explosion-proof gland, or 3/4" NPT steel conduit, with 0.5 to 2.5 mm² (20 to 13 AWG) conductors. Ensure the cable gland is installed correctly and fully tightened. All unused cable/conduit entries must be sealed with a suitable certified sealing plug (one plug is supplied).

| Type | Cable Spec | Max Length |
|---------|----------------------------|------------|
| Mod Bus | AWM2464 AWG26~AWG12 Shield | 1000meters |

6.5 Cable and Earth/Ground regimes

Effective Earth/Ground bonding is important to ensure good EMC and RFI immunity.

The following diagrams show examples of how to earth/ground bond the cable at enclosures. The same principles apply to conduit installations. These bonding techniques provide good RFI/EMC performance. Earth/ground loops must be avoided to prevent the risk of false signal variation.

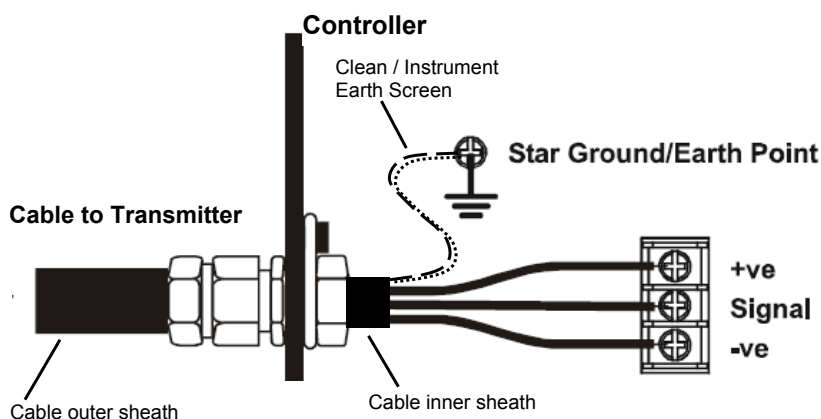

Diagram 9: Controller Grounding

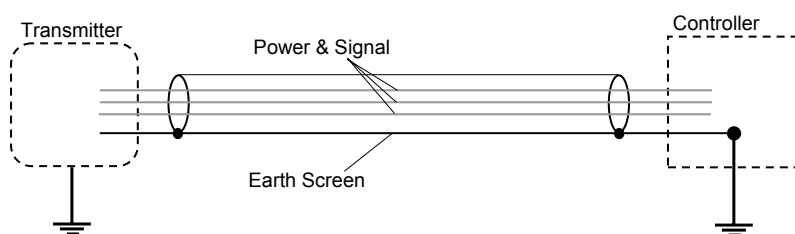
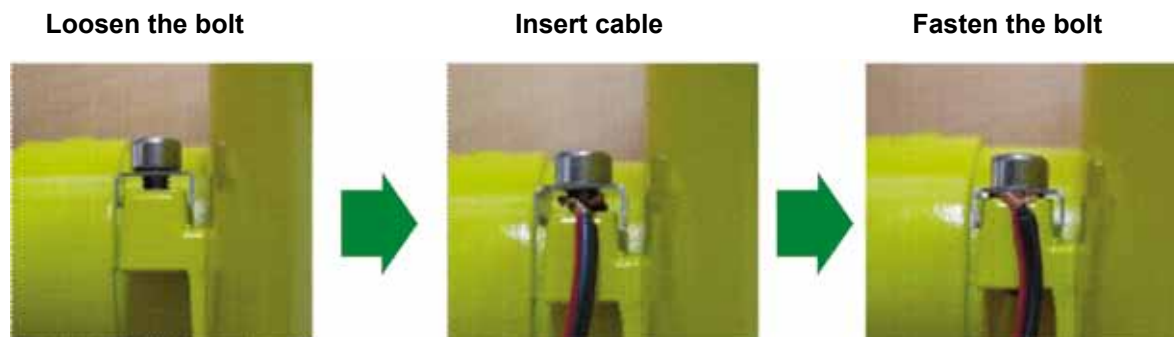

Diagram 10: System grounding

The Earth Screen of the field cable should be “tied to Earth” or connected to Ground at one point only. It is common practise to adopt a STAR EARTH connection regime where all instrumentation Screens are connected at one common point.

The Screen at the other end of the cable should be “parked” or terminated into a blank terminal.

The following diagrams show how to install the wire into the ground screw of the enclosure.



6.6 Ground Terminal Wiring

Internal Ground connection: Utilize the shield of the wiring cable recommended in the wiring instructions. For connection to this terminal. Twist the shield wire to avoid stray shield wires, Loosen the screw sufficiently and wrap the wire around the screw in a “U” shape. Raise the clamp and place the wire between the clamp and ground base, lower the clamp and tighten the screw to 6.9lb-in torque.

External Ground Connection: If required by local authority, Utilize a No 14 AWG copper, (Stranded or Solid), wire. Loosen the screw sufficiently to enable ‘wrapping the wire around the screw in a “U” shape. Raise the clamp and place the wire between the clamp and ground base, lower the clamp and tighten the screw to 10.4lb-in torque.

7 Default configuration

The Sensepoint XCD transmitter is supplied with the following default configuration.

| Function | Value/Setting | Meaning |
|-----------------------|--|--|
| Sensor Type | Automatic according to Sensor type connected | XCD recognizes the XCD sensor cartridge according to the gas type within its own sensor family i.e. mV, EC or O ₂ . |
| Signal output | ≥0.0<1.0 mA | Fault (refer to table 5 section 12.3 for details) |
| | 2.0 mA or 4.0 mA (17.4mA) | Inhibit (during configuration/user settings) For Oxygen, 2.0 mA or 17.4 mA |
| | 4.0 mA to 20.0 mA | Normal gas measurement |
| | 22.0 mA | Maximum over range |
| Alarm Relay 1* | Value is sensor dependant | Lower alarm level |
| | De-energized | Energizes on alarm |
| | Contact Normally Open (NO) | Closes on alarm |
| Alarm Relay 2* | Value is sensor dependant | Higher alarm level |
| | De-energized | Energizes on alarm |
| | Contact Normally Open (NO) | Closes on alarm |
| Fault Relay | <1mA | Detector Fault |
| | Energized | De-energizes on alarm |
| | Contact Normally Open (NO) | Closes on alarm |
| Inhibit | 2.0 mA (default) or 4.0 mA for Toxic and Flammable 2.0 mA (default) or 17.4 mA For Oxygen | Signal output inhibited during menu use. If any relay is set to inhibit relay, then inhibit relay will be activated. |
| Timeout | Disabled | No inhibit timeout. The detector waits for a button press before returning to the previous state/setting. Timeout period can be set in 'Configure Inhibit' menu in Configuration Mode . |
| Password | 0000 (Disabled) | 0000 (Password disabled). If changed then password is activated. |
| Location (Tag Number) | 0000 | Optional feature to identify the location or User's "Tag" number of the XCD |
| Temperature | °C | Option to have °C or °F |
| ModBus | ID, baud rates and Parity bit | ID : 1 Baud rates : 19,200 Parity bit : EVEN |

* Alarm relays automatically reset when reading falls within alarm thresholds. If relay configured to LATCH, then relays must be reset using the Magnetic Wand.

Table 3: Default configuration

| Gas Name | Default Range | Lower Alarm | Lower Alarm Type | Higher Alarm | Higher Alarm Type |
|-------------------|---------------|-------------|------------------|--------------|-------------------|
| Oxygen | 25.0%VOL | 19.5%Vol | Falling | 23.5%Vol | Rising |
| Hydrogen Sulfide | 50.0ppm | 10.0ppm | Rising | 20.0ppm | Rising |
| Carbon Monoxide | 300ppm | 100ppm | Rising | 200ppm | Rising |
| Hydrogen | 1,000ppm | 200ppm | Rising | 400ppm | Rising |
| Nitrogen Dioxide | 10.0ppm | 5.0ppm | Rising | 10.0ppm | Rising |
| Flammable IR | 100%LEL | 20%LEL | Rising | 40%LEL | Rising |
| Flammable CAT | 100%LEL | 20%LEL | Rising | 40%LEL | Rising |
| Carbon Dioxide IR | 2.00%Vol | 0.40%Vol | Rising | 0.80%Vol | Rising |

For details of how to change the configuration of the Sensepoint XCD please refer to section 13.

8 Normal Operation

Sensepoint XCD is supplied configured and ready for use according to the “Default Settings” table shown above. However these setting may be tailored to a specific application requirement using the Sensepoint XCD configuration menu system.

Access to the Sensepoint XCD transmitter’s configuration menus system is via the Magnetic Activation Tool.

8.1 Display Screen

The Sensepoint XCD display features an LCD with Numeric and bar-graph gas concentration data, alpha-numeric warning and status indication, a target for magnetic switch activation and the UP/DOWN/ESC/ENTER zones for remote configuration. The LCD is also backlit with hi-intensity multi-colour LED indicator to show NORMAL, ALARM and FAULT status.

During normal operation the instrument display shows a steady GREEN backlight.

During Low and High Gas Alarm it displays a flashing RED backlight

During Fault condition the instrument display shows a flashing YELLOW backlight.

The screen is visible through the window of the transmitter’s cover. The display shows the gas concentration (both graphically and numerically), range, units, alarm/ fault status, etc.

Note: The detector display may become sluggish in sub-zero temperatures and possibly unclear at temperatures below -40 °C, but the detector continues its gas monitoring function. The display is not damaged and recovers when the temperature increases.

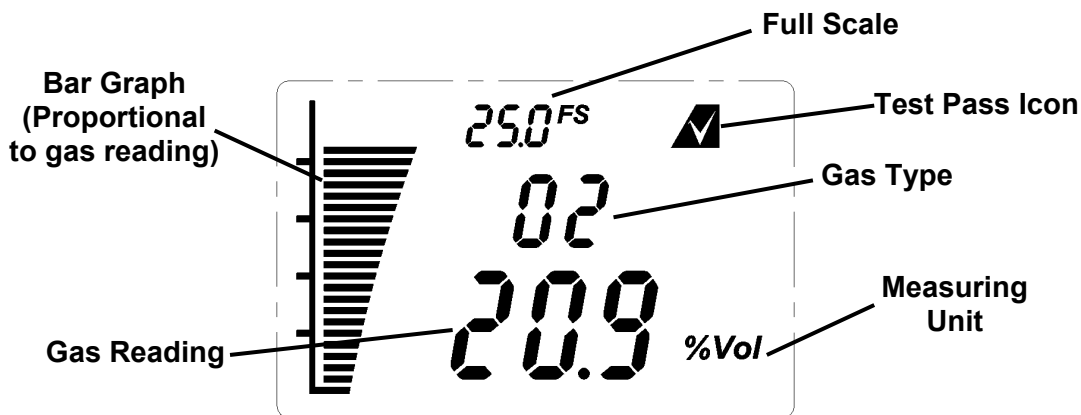

Diagram 11: Example of a O₂ Transmitter Display screen – Normal Operation

8.2 System Status

Display indications, current output and relay states for various operational conditions are shown in the following table. For further details of error messages and trouble shooting see section 12.3.

| System Status | | | | | | |
|--|--|--|----------------|----------------|-------|---------------------|
| Status | Display | Current Output | Relay | | | Back Light |
| | | | A1 | A2 | Fault | |
| Fault: Circuit or sensor error | F-XX fault number with fault icon blinking | 0-1.0 mA | | | ✓ | Yellow, flashing |
| System Fault | N/A | 0-0.15mA | | | | |
| Note: In the event of processor failure the watchdog will automatically reset the system for recovery. | | | | | | |
| Warning | W-XX warning number with fault icon blinking | Dependent on system status | | | | Green Steady |
| Normal | 0.0 Gas concentration | 4-20 mA | | | | Green Steady |
| Alarm 1 | Gas concentration. 1 st alarm icon blinking | 4-20 mA | ✓ | | | Red, flashing |
| Alarm 2 | Gas concentration. 2 nd alarm icon blinking | 4-20 mA | ✓ ¹ | ✓ | | Red, flashing |
| Over-range | Full scale icon and reading blinking | 22mA | ✓ | ✓ ² | | Red, flashing |
| Inhibit | Inhibit icon dependent on Menu command. If any relay is set to inhibit relay, then inhibit relay will be activated. | 2 or 4mA depending on configuration. Note: 2 or 17.4mA for Oxygen version | | | | Green Steady |

Table 4: System status

Note:

1. For Oxygen, A1 relay will not be activated because AL1 is configured to activate above 23.5 %Vol (in Rising Alarm configuration).

2. For Oxygen, A2 relay will not be activated because AL2 is configured to activate below 19.5 %Vol (in Falling Alarm configuration).

8.3 Magnetic Wand Activation

The magnetic wand is used as a tool to allow the user to communicate with the Sensepoint XCD transmitter. Communication with the XCD is achieved by positioning the Magnetic Wand at one of three different positions on the front glass window of the Sensepoint XCD transmitter. Activation of the switches is verified by observing the Magnetic Wand Activation Icon on the LCD display

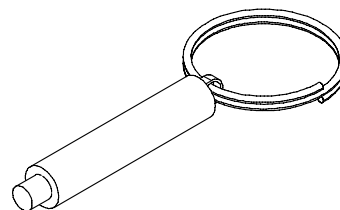

Hold the Magnetic Wand in position for up to 2 seconds = ●

Hold the Magnetic Wand in position for 3 seconds or more = ⊙

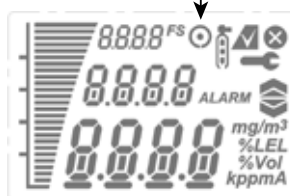

8.4 Mode Structure

Sensepoint XCD has 3 operating modes.

1. **Monitoring mode**, is the normal operating status while XCD measures and displays gas concentration. The fault/warning status is periodically checked, relay contacts are activated according to the configuration.
2. **Configuration mode**, this mode allows parameters relating to the configuration of the Transmitter functions to be changed according to specific needs. This mode can be protected by a password mechanism to prevent unauthorised changes being made.
3. **Review mode**, allows the user to view the current configuration settings.

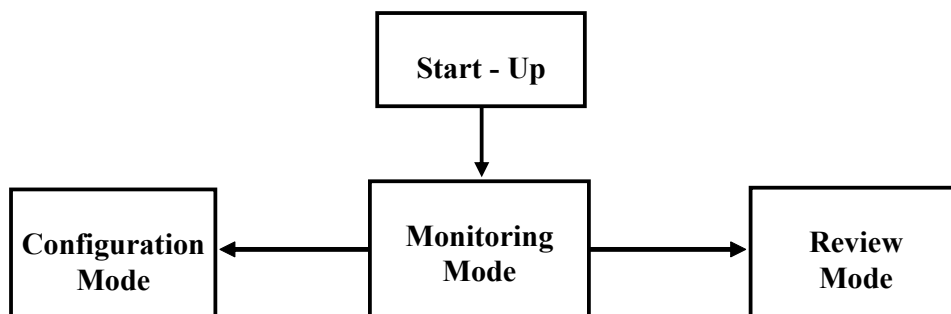

Diagram 12: Mode Structure

Further details of the information available and configuration options for the Sensepoint XCD can be found in Section 13. of this manual.

9 First time switch on (Commissioning)

WARNING

The following procedure requires the Transmitter Cover to be removed while carrying out supply voltage checks. Therefore the appropriate permits to work should be sought in preparation.

Prior to carrying out any HOT WORK ensure local and site procedures are followed. Ensure that the associated control panel output actuation is inhibited so as to prevent false alarms.

Caution: The following procedure should be followed carefully and only performed by suitably trained personnel

Note: Calibration is mandatory before the detector can be used for gas monitoring. Refer to Section 10.1 Calibration for the proper procedure.

1. Remove the transmitter housing cover and detach the display unit by lifting the semi-circular handle and pulling the assembly directly away from the termination module (without twisting it)
2. Configure the detector's analogue output signal configuration for Current SINK or Current SOURCE operation using the selector switch located on the back of the display module. The default setting is Current SOURCE.
3. Check that all electrical connections are terminated correctly as per section 6.
4. Switch On the external power supply to the transmitter at the safe area gas detection controller (or PLC).
5. Using a Digital Multi Meter (DMM), check the Supply Voltage at the terminals 1 (24V) and 2 (0V), this should be a minimum supply voltage of 16Vdc (Maximum supply voltage is 32V DC)
6. Switch Off the external power to the detector.
7. Refit the Display Module and Cover.

Note: Ensure that none of the wires in the terminal area cause an obstruction when refitting the Display Module. Ensure that the socket on the Display Module is fully engaged in the Display Module Connector on the Terminal Module.

8. Switch On external power to the detector.
9. All the display icons/text/numbers are displayed for 3 seconds.

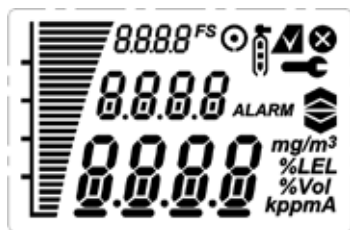

10. A start up sequence will then be displayed, similar to the one shown in Diagram 15.

Note:

For a full description of each screen shown in Diagram 13., please refer to Section 13.3 “Review Mode” of this Manual.

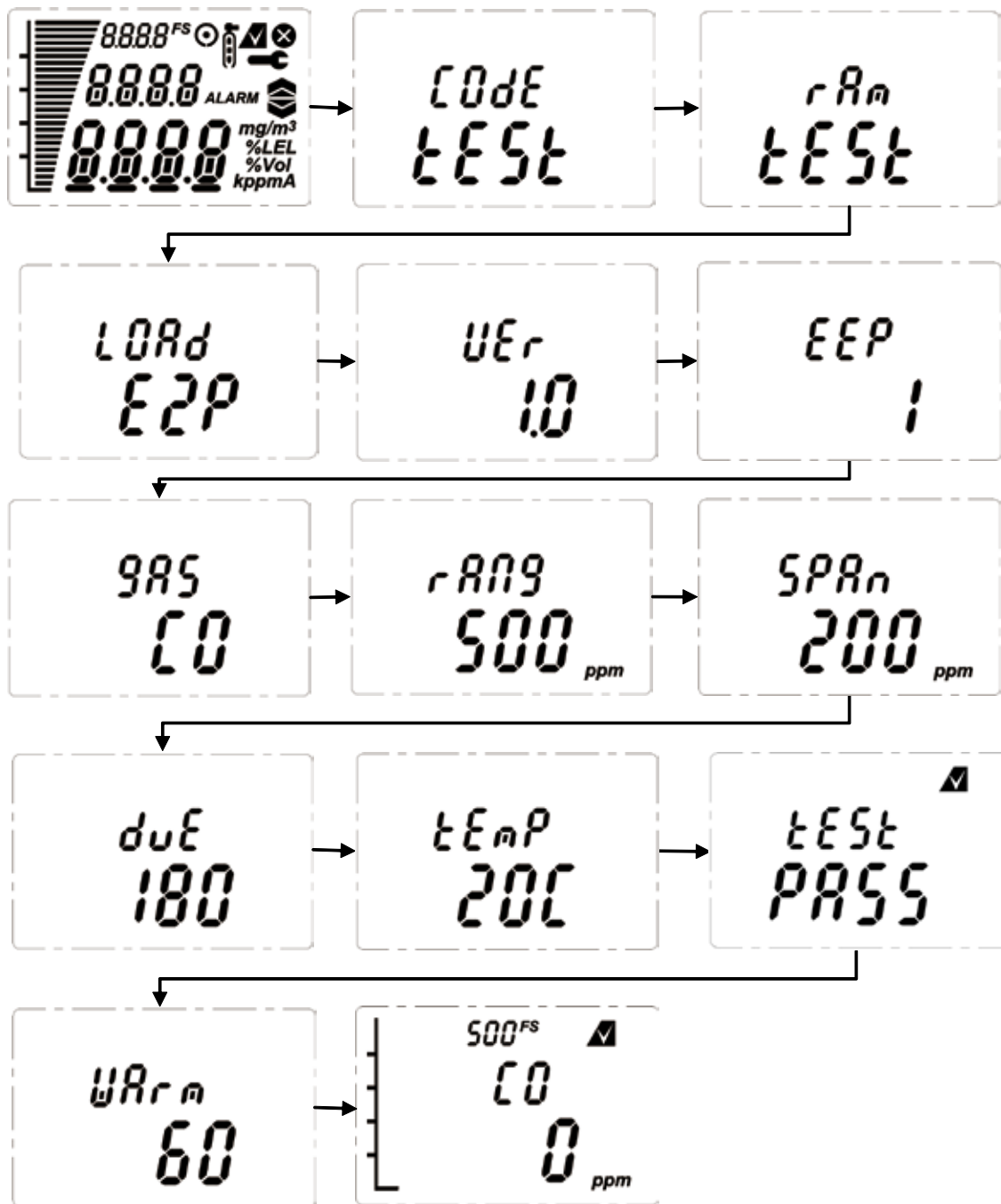

Diagram 13: Normal Start up procedure (For the CO sensor version)

11. The warm up countdown of 60 seconds (depending on the gas type) is then displayed.
12. Normal **Monitoring Mode** is then resumed.

10 Response Check and Calibration

It is recommended to periodically carry out a gas response check on the Sensepoint XCD to ensure correct operation. This may be done in two ways;

1. A simple Response Check often referred to as a “BUMP TEST” is a test using calibration gas applied to the sensor via the nozzle of the Weather Protection or using the Sensepoint XCD Gassing Cap.

If a BUMP TEST is done via the Weather Protection nozzle it may be necessary in windy conditions to increase the flow rate of the test gas by a further 1 LPM, OR, to shelter the weather protection from the wind.

2. A full gas calibration of the sensor as described in the following section, using ONLY the Sensepoint XCD Gassing Cap (Part No.: S3KCAL).

10.1 Zeroing and span calibration

Caution: Before initial calibration allow the detector to stabilize for 30 minutes after applying power.

When in zeroing and span calibration mode the current output from the detector is inhibited (default 2mA) to avoid false alarms.

For Flammable gas calibration use a calibration gas concentration of between 25%LEL and 75%LEL to ensure that the required accuracy can be attained.

For Hydrogen Sulfide type sensors refer to section 10.1.2 before conducting zero and span calibration.

To calibrate the detector, use an appropriate span gas cylinder, constant flow regulator AND the Sensepoint XCD Gassing Cap (see section 4.7). The flow rates used for calibration gas are as follows:

| Gas Type | Flow rate (L / Min) |
|--------------------------------|---------------------|
| Air or N ₂ for Zero | 0.5 to 1.0 |
| Flammable CAT | 1 to 1.5 |
| O ₂ | 0.5 to 1.0 |
| H ₂ S | 0.5 to 1.0 |
| CO | 0.5 to 1.0 |
| H ₂ | 0.5 to 1.0 |
| NO ₂ | 0.5 to 1.0 |
| Flammable IR | 0.4 to 0.6 |
| CO ₂ IR | 0.4 to 0.6 |

A compressed air cylinder (20.9%Vol oxygen) should be used to perform the zero calibration if the area where the detector is located contains any residual amount of the target gas. If no residual gas is present then the background air can be used to perform the zero calibration. Contact your Honeywell Analytics representative for details of suitable calibration kits.

To calibrate the detector follow the procedure below.

Note: the Oxygen sensor does not require a zeroing procedure. Background air (20.9%Vol oxygen) can be used to span the oxygen sensor in place of a compressed air cylinder (20.9%Vol oxygen). For oxygen sensors only do parts 1-4, 12, 13 (if compressed air cylinder is used), 14-17 and 22 of the procedure below.

(ZERO CALIBRATION)

1. If the ambient air is NOT considered reliable to use to set the ZERO, then remove the weather protection and fit the Gassing Cap accessory (see Section 4.3) onto the sensor and apply a clean source of zero gas or compressed air.
2. To access the calibration menu, hold the end of the magnet over the switch located at the top center of the detector display (✓) for at least 3 seconds and then remove.
3. The display will indicate the first configuration mode menu 'SEt CAL'.



4. Put the magnet over the '✓' switch again and move to enter the Calibration menu.
5. The display will show the current gas reading, and the '↑' icon flashes.



6. When the zero gas reading is stable use '✓' to confirm zero calibration.
7. If successful the display shows 'ZEro PASS' (if not successful, the display shows 'ZEro FAIL' and returns to configuration mode).

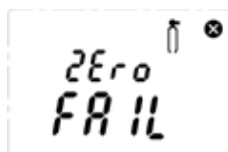
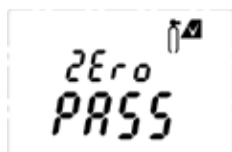

8. If using zero-air, turn it off. Zeroing is complete and saved.
9. The display shows 'SPAN' with 'YES' flashing.



10. If span calibration is required use '✓' proceed to the next step. If span calibration is not required, use '▲▼' to select 'No' and '✓' to return to configuration mode.

(SPAN CALIBRATION)

11. The display shows the current calibration span gas concentration while flashing the 'GAS' icon. Use '▲▼' to change the calibration span gas concentration, and '✓' when required span calibration level is set.



12. The display will show the current gas reading, and the 'GAS' icon flashes.
13. Connect the regulator to the span gas cylinder.
14. Apply the span gas to the sensor using the Sensepoint XCD Gassing Cap (see section 4.7 for description). The live gas reading is displayed. When the reading is stable, use '✓' to confirm span calibration.



15. If the sensor has been replaced the following display may be shown.



16. Use '▲▼' to select 'YES' if the sensor has been replaced or 'No' if it has not been replaced.
17. If the span calibration is successful the instrument will briefly display 'SPAN PASS' (if fails 'SPAN FAIL' displayed and returns to configuration mode).

Note: the calibration due warning counter is reset after a successful calibration. See section 12.3 for further details of setting a calibration due warning.



18. The display alternates between "Purg gAS" and the gas reading to indicate that the unit is expecting the span gas to be removed from the sensor.



19. Promptly switch off the calibration span gas and remove the Sensepoint XCD Gassing Cap from the sensor to allow the gas to disperse.
20. When the reading falls below 50% of the calibration gas level the display indicates a countdown (up to 180 seconds dependant on gas type).

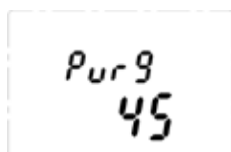

21. When the countdown is finished, the calibration procedure is complete.
22. The instrument returns to the 'Set CAL' menu. Activate the '▲' or '▼' switch to select another menu or select 'Quit' to return to normal monitoring mode.



Note: Remember to always replace the Weather Protection and other accessories.

10.2 Zeroing and span calibration of Hydrogen Sulphide sensors

Hydrogen Sulphide sensors can be affected by extreme humidity changes. A sudden increase in ambient humidity can result in a short-term positive drift in the instrument's reading. A sudden decrease in ambient humidity can result in a short-term negative drift in the instrument's reading. These are most likely to be noticed during calibration with dry or cylinder gas.

When calibrating Hydrogen Sulphide cartridges the following should be taken into account while following the procedure in 10.1:

1. To zero the sensor, use a compressed air cylinder of 20.9%Vol oxygen (not Nitrogen). Do not use background air.
2. Apply the gas to the sensor for three minutes before using '✓' to confirm the zero calibration.
3. If a span calibration is to be performed, the span calibration gas should be applied to the sensor immediately after the zeroing procedure. Do not allow the sensor to return to ambient air conditions between steps 2 and 3.
4. Apply the span gas for two minutes before using '✓' to confirm the span calibration.

11 General Maintenance

WARNINGS

Access to the interior of the transmitter, when carrying out any work, must only be conducted by trained personnel.

Care should be taken when removing and refitting the Sensepoint XCD plug-in Sensor Cartridge to the Sensor Socket so that damage to the connection pins can be avoided.

Before carrying out any work ensure local regulations and site procedures are followed. Appropriate standards must be followed to maintain the overall certification of the sensor and transmitter.

To reduce the risk of ignition of hazardous atmosphere, de-classify the area or disconnect the equipment from the supply circuit before opening the transmitter enclosure. Keep assembly tightly closed during operation.

Never attempt to open a junction box/enclosure or replace/refit the sensor in potentially hazardous atmospheres.

Take care when handling sensors as they may contain corrosive solutions.

Do not tamper with or in any way disassemble the sensor.

Do not expose to temperatures outside the recommended ranges.

Do not expose sensors under storage conditions to organic solvents or flammable liquids.

At the end of their working life, replacement electrochemical sensors for oxygen and toxic gas must be disposed of in an environmentally safe manner. Disposal should be according to local waste management requirements and environmental legislation.

Alternatively, old replaceable sensors may be securely packaged and returned to Honeywell Analytics clearly marked for environmental disposal.

Electrochemical sensors should NOT be incinerated as this action may cause the cell to emit toxic fumes.

Honeywell Analytics recommends that gas detectors are tested and re-calibrated on a six-monthly basis, or according to site practice. For remote Flammable or Toxic sensors are used with the XCD Transmitter, please refer to the individual sensor manuals for specific recommended calibration periods.

11.1 Operational Life

The pellistors used in the Catalytic flammable gas sensor can suffer from a loss of sensitivity when in the presence of poisons or inhibitors, e.g. silicones, sulphides, chlorine, lead or halogenated hydrocarbons. The pellistors are poison resistant to maximize the operational life of the Catalytic flammable sensor. A typical operating life, subject to the presence of poisons/inhibitors is 36 months.

The NDIR (infrared) flammable gas sensor is not affected by the above-mentioned poisons and therefore has a longer life span. A typical operating life is 5 years.

Typical life of a toxic gas sensor is dependant on the application, frequency and amount of gas exposure. Under normal conditions (3 monthly visual inspection and 6 monthly test/re-calibration), the XCD Oxygen and other toxic sensors have an expected life equal to or greater than 24 months.

Refer to section 12 for sensor replacement procedures.

Caution: Oxygen deficient atmospheres (less than 6%V/V) may result in inaccuracy of reading and performance.

12 Servicing

WARNINGS

Take care when handling sensors as they may contain corrosive solutions. Do not tamper or in any way dis-assemble the sensor. Do not expose to temperatures outside the recommended range. Do not expose sensor to organic solvents or flammable liquids.

Care should be taken when removing and refitting the Sensepoint XCD plug-in Sensor Cartridge to the Sensor Socket so that damage to the connection pins can be avoided.

At the end of their working life, replacement electrochemical sensors for oxygen and toxic gas must be disposed of in an environmentally safe manner. Disposal should be according to local waste management requirements and environmental legislation. Alternatively, old replaceable sensors may be securely packaged and returned to Honeywell Analytics clearly marked for environmental disposal.

Electrochemical sensors should NOT be incinerated as this action may cause the cell to emit toxic fumes.

**Caution: The following procedure should be followed carefully and only performed by suitably trained personnel.
A fault condition will be signalled by the detector if the sensor is removed with the unit under power.**

12.1 Sensor replacement

The Flammable Catalytic and Toxic ECC sensor cartridge that are used with the Sensepoint XCD Sensor Socket have no serviceable parts. When they have reached the end of their operational life, simply replace the cells.

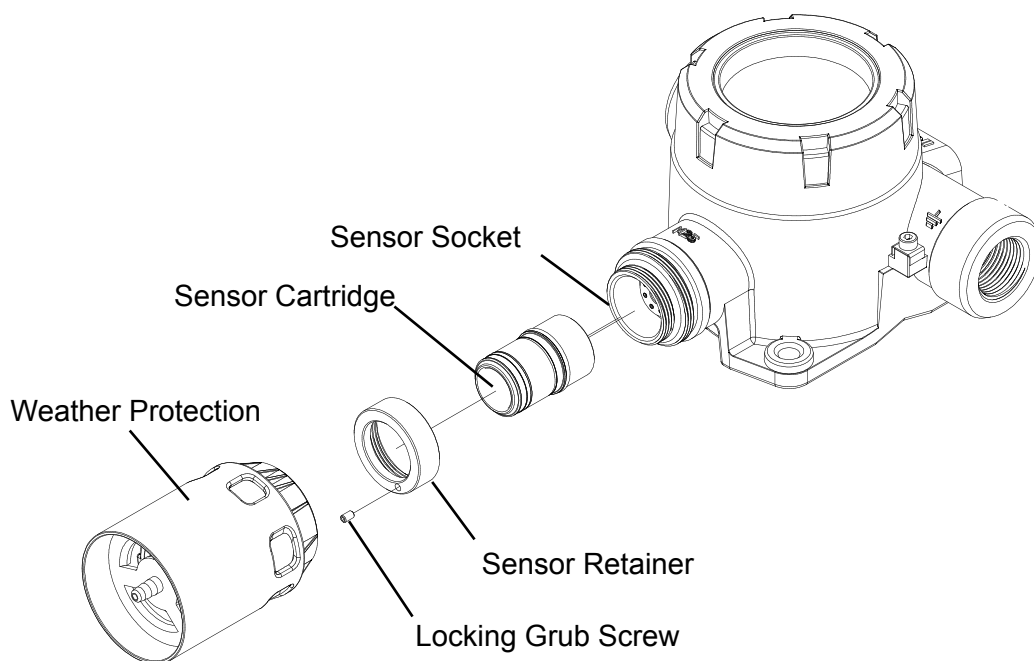

Diagram 14: Sensor Replacement

To replace the plug-in sensor of a Sensepoint XCD Sensor Socket use the following procedure:

1. **Important:** Remove the Power from the Sensepoint XCD Transmitter
2. Remove the Weather Protection or other accessories from the sensor socket thread.
3. Loosen the Locking Grub Screw and unscrew the Sensor Retainer
4. Carefully pull the old Sensor from the sensor socket without twisting.
5. Fit the new Sensor in its place
6. Calibrate sensor

WARNING

Ensure that the same Gas Type and Range of Sensor is fitted in place of the old Sensor.

Care should be taken when removing and refitting the Sensepoint XCD plug-in Sensor Cartridge to the Sensor Socket so that damage to the connection pins can be avoided.

The sensor head must be fitted with the supplied weather protection, and mounted so that the sinter is pointing downward to provide ingress protection IPX6.

The weather protection is a potential electrostatic charging hazard. The manufacturer's instructions should be observed.

12.2 Replacing Modules within the Transmitter

Two replaceable module assemblies are located within the transmitter housing. The Display Module and the Terminal Module.

The Display Module is simply removed by unplugging it from the Terminal Module (this procedure is done during normal installation).

To replace the Terminal Module, use the following procedure:

1. Unscrew and remove the Transmitter Cover
2. Lift the handle and un-plug and remove the Display Module.
3. Unplug the connection terminals and lift them clear of the Terminal Module.
4. Unplug the connector for the XCD sensor.
5. Loosen and remove the three “cross-headed” screws that secure the Terminal Module to the Transmitter housing.
6. Carefully lift the Terminal Module from the transmitter housing.
7. Fit the new Terminal Module using the above procedure in reverse order.

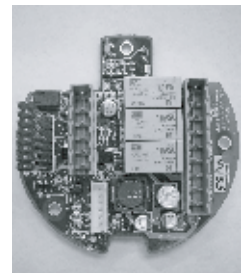
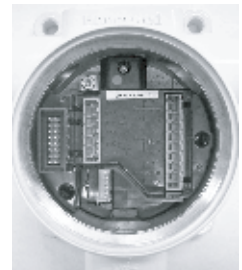

12.3 Faults and Warnings

The table below provides details of possible error.

| Message | Description | Action |
|---------|--|---|
| W-01 | Calibration needed | The unit has not been calibrated for the configured calibration interval Calibration is necessary due to change of sensor/gas type |
| W-02 | Transmitter Temperature limits exceeded | Use '✓' to clear when within limits |
| W-03 | Alarm setting needs to be configured | Re-configure alarm settings such that upper alarm should not exceed user configured scale |
| W-04* | Over-range warning | Use '✓' to clear when within limits |
| W-05* | The sensor is switched off to prevent it from being deteriorated | Make sure that there is no flammable gas in the air and use '✓' to clear when within limits |
| F-01 | Internal I2C failure | Cycle power to detector. Replace detector |
| F-02 | Cell failure | For Toxic, replace sensor For Flammable/IR, cycle power to detector. Replace sensor |
| F-03 | Significant zero drift | Re zero/calibrate |
| F-04 | Unexpected sensor fitted | Replace sensor |
| F-05 | EEPROM is corrupted | Reset transmitter. If fault still appear, replace transmitter |
| F-06 | Low supply voltage | Reset transmitter. If fault still appear, replace transmitter |
| F-07 | SRS processor failure | Reset transmitter. If fault still appear, replace transmitter |
| F-08 | RAM read/write fault | Reset transmitter. If fault still appear, replace transmitter |
| F-09 | Info. memory corrupted | Reset transmitter. If fault still appear, replace transmitter |
| F-10 | Code Memory corrupted | Reset transmitter. If fault still appear, replace transmitter |
| F-11 | DAC output failure | Check load resistor or sink/source mode switch was configured properly |
| F-12 | Heater failure | Reset transmitter. If fault still appear, replace transmitter |
| F-13 | Supplied voltage failure | Check supply voltage. Replace detector |

*Note : W-04 and W-05 are only for flammable catalytic bead sensors. For other gases, gas reading will blink on the LCD instead of the over-range warning.

Table 5: Fault and Warning List

13 Menu's and Advanced Configuration

13.1 Abort Function

In Review Mode or Configuration Mode the user can escape one step back from the current position using the Abort Function. To do this the user must activate the Enter switch for more than 3 seconds with the Magnetic Wand. Switching between each pair of modes or between menus and sub menus are shown in the following table.

| From | To | Example |
|-----------------------------|------------------------------|--|
| Review Mode | Monitoring Mode | Activate Enter switch for more than 3 seconds while in Review Mode |
| Configuration Mode | Monitoring Mode | Activate Enter switch for more than 3 seconds while navigating menus in the Configuration Mode |
| Configuration Mode sub menu | Configuration Mode main menu | Activate Enter switch for more than 3 seconds while in a sub menu |

Table 6: Transmitter menu switching

13.2 Configuration Mode

The table below shows the functions available via the configuration menu that can be displayed on the transmitter and accessed using the Magnetic Wand.











The instrument will show the main Menu when the “Enter” switch is activated with the Magnetic Wand and held for at least 3 seconds.

The Menu is password protected to prevent any unauthorized changes. The password is initially disabled and the default password is ‘0000’. If the default password is changed to other than ‘0000’, then the password is enabled automatically and requested when entering Configuration Mode.

With the Menu showing, the following functions can be performed: calibration, bump test, sensor selection and configuration of parameters such as measuring range, calibration gas level, calibration interval, inhibit current, inhibit timeout, alarm setting, relay setting, password change, location setting, temperature unit reading, force analogue output and alarm function checks.

While in Configuration mode, the output current of the transmitter is inhibited to prevent false alarms.

Names, displays and descriptions for each menu item in Configuration Mode are shown in the following table.

| Menu | Display | Description |
|--------------------------|---|--|
| Set Calibration |  | Execute zero/span calibration Set calibration gas level After zero, the option exists to proceed with span calibration, or return to the Menu. |
| Select Sensor |  | Select the type of sensor from the sensor list. This menu is only available for flammable / IR sensor. |
| Select Gas |  | Select the type of gas from the list. This menu is only available for flammable / IR sensor. |
| Set Range |  | Set measuring range |
| Configure Inhibit |  | Select inhibit current Set timeout option (5 minute increments) |
| Set Password |  | Enable/disable password Set password Default – no password (Select '0000') |
| Set Calibration Interval |  | Set calibration interval, 30 to 365 days User configurable option to display warning |
| Bump Test |  | Execute a 'bump' test to check gas response of the sensor. |
| Force Current |  | Force analogue output to test functionality of GD control system during system commissioning. |
| Set Alarms |  | Set alarm 1, alarm 2 levels, functionality and operation (none/falling/rising) |
| Set Relays |  | Set relay 1,2,3 type (alarm 1, alarm 2, fault and inhibit) and action (energized/de-energized) |







| | | |
|-----------------------|--|--|
| Relay Operation |  | Configure relay on delay time, relay off delay time and latch/non-latch |
| Set Location |  | Set location (or TAG number) |
| Set Temperature Unit |  | Change temperature display unit. °C (Celcius) or °F (Fahrenheit) |
| Check Alarm functions |  | Simulate alarm situation to check the alarm system without gas present at the sensor |
| Set ID |  | Change ModBus slave ID, baud and parity bit setting (ModBus version only) |
| Quit |  | Return to Monitoring mode |

Table 7: Transmitter menu descriptions



** Note : "Select Sensor" and "Select Gas" menus are only available for flammable/IR sensors.*

Diagram 15: Configuration Mode

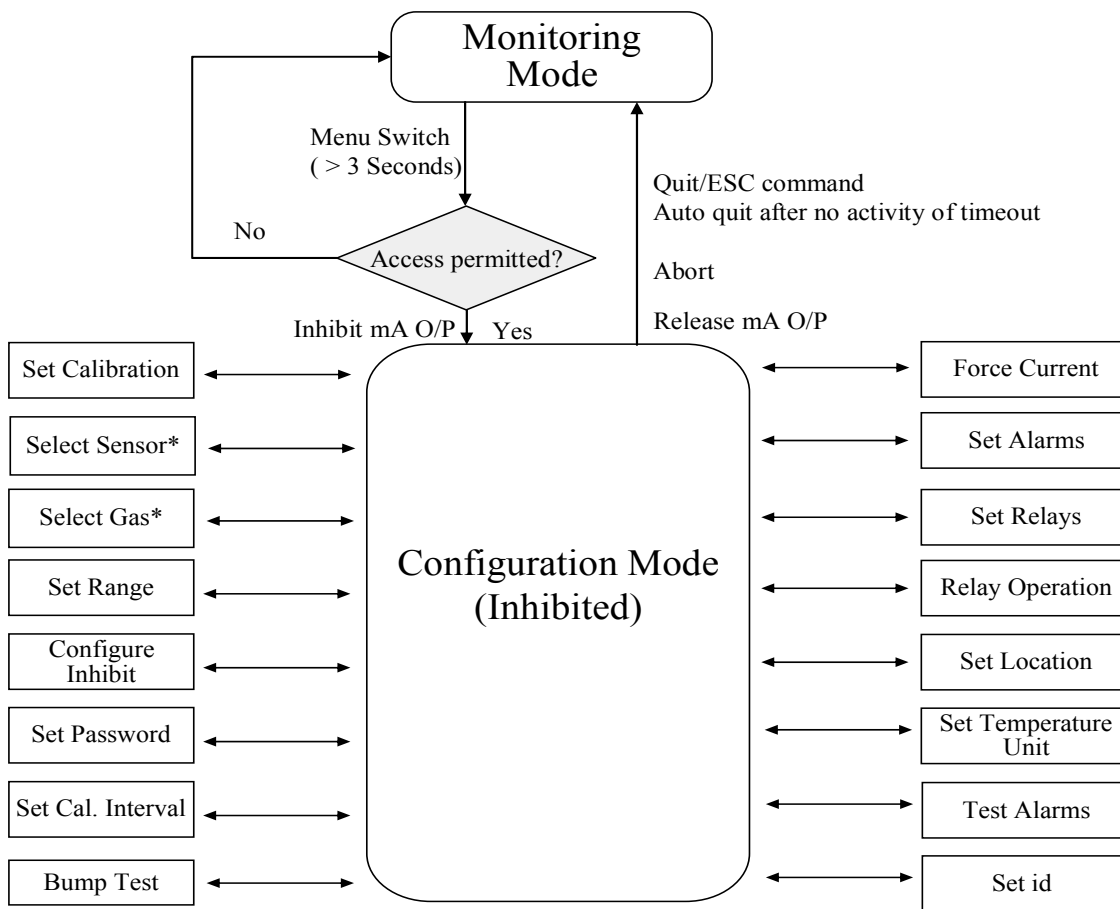
13.2.1 Configuration mode operation table

Configuration mode allows the user to perform calibration and configure parameters such as full scale range, calibration gas level, calibration interval, inhibit current & timeout, alarm settings, relay settings, set a password, etc. To activate Configuration mode hold the magnet over the ENTER switch for at least 3 seconds and then remove. Configuration mode can be password protected to prevent unauthorized personnel from changing parameters. Initially the password is set to '0000' meaning it is disabled. While in Configuration mode, the output current of the detector is inhibited to prevent false alarms.

Use the table below to help navigate the menus and make configuration changes. The menus are shown in the left hand column. Use **▲▼** to select the required menu and **✓** to enter. Follow the information and instructions in the table from left to right from the required menu.

| ▲▼ OK | ▲▼ | OK | ▲▼ | OK | ▲▼ | OK | ▲▼ |
|-----------------------|---|----|--|----|--|----|---|
| Set CAL ¹ | GAS NAME, ZERO CONCENTRATION AND FLASHING '0' ICON DISPLAYED. APPLY ZERO GAS AND USE '✓' WHEN READING IS STABLE. 'ZERO PASS' DISPLAYED IF OK, 'Zero FAIL' IF NOT. | ⇨ | 'SPAN' DISPLAYED AND 'YES' FLASHING TO ASK IF YOU NOW WANT TO PERFORM SPAN CALIBRATION. USE '✓' TO PROCEED OR USE '▲▼' TO SELECT 'No' AND RETURN TO MENU MODE. | ✓ | 'GAS' TARGET CONCENTRATION FLASHING AND '0' ICON DISPLAYED. USE '▲▼' TO CHANGE GAS CONCENTRATION AND '✓' TO START SPAN CALIBRATION. | ✓ | GAS NAME, CURRENT CONCENTRATION AND FLASHING '0' ICON DISPLAYED. APPLY SPAN GAS AND USE '✓' WHEN READING STABLE. IF OK 'PASS' & 'Purg' DISPLAYED (IF FAIL 'SPAN FAIL' DISPLAYED AND RETURNS TO MENU). REMOVE SPAN GAS. WHEN READING <50% OF SPAN POINT, COUNTDOWN BEGINS & UNIT RETURNS TO MENU MODE. |
| SEL ² SENS | 'SENS' DISPLAYED WITH SENSOR TYPE DISPLAYED. USE '▲▼' TO SELECT DIFFERENT SENSOR. | ✓ | IF SENSOR TYPE IS CHANGED, 'CAL YES' DISPLAYED TO ASK IF YOU NOW WANT TO PERFORM CALIBRATION. USE '✓' TO PROCEED OR USE '▲▼' TO SELECT 'No' AND RETURN TO MENU MODE. | ✓ | | | |
| SEL 9AS ² | '9AS' DISPLAYED WITH GAS TYPE DISPLAYED. USE '▲▼' TO SELECT DIFFERENT GAS. | ✓ | IF GAS TYPE IS CHANGED, 'CAL YES' DISPLAYED TO ASK IF YOU NOW WANT TO PERFORM CALIBRATION. USE '✓' TO PROCEED OR USE '▲▼' TO SELECT 'No' AND RETURN TO MENU MODE. | ✓ | | | |
| Set rAn9 | BAR GRAPH INDICATING CURRENT RANGE, 'rAn9' DISPLAYED & CURRENT RANGE FLASHES. USE '▲▼' TO SELECT DIFFERENT RANGE. | ✓ | IF RANGE IS CHANGED, 'CAL' DISPLAYED AND 'YES' FLASHING TO ASK IF YOU NOW WANT TO PERFORM CALIBRATION. USE '✓' TO PROCEED OR USE '▲▼' TO SELECT 'No'. | ✓ | IF RANGE IS CHANGED, 'ALrm' DISPLAYED AND 'YES' FLASHING TO ASK IF YOU NOW WANT TO MODIFY ALARM SETTINGS. USE '✓' TO PROCEED OR USE '▲▼' TO SELECT 'No' AND RETURN TO MENU MODE. | ✓ | UNIT RETURNS TO MENU MODE |
| Conf Inhb | 'Inhb' DISPLAYED WITH 'Inhb' ICON FLASHING. CURRENT INHIBIT mA VALUE FLASHES. USE '▲▼' TO SELECT NEW VALUE (2 OR 4mA TOXICS, OR 2 OR 17.4mA OXYGEN VERSION). | ✓ | 'time' DISPLAYED WITH 'time' ICON. FLASHING CURRENT INHIBIT TIMEOUT PERIOD (MINUTES) FLASHES. USE '▲▼' TO SET NEW TIMEOUT. (IF SET TO 0 OUTPUT IS PERMANENTLY INHIBITED) | ✓ | UNIT RETURNS TO MENU MODE | | |
| Set PASS | 'PASS' DISPLAYED WITH FIRST DIGIT PLACE ICON OF THE PASSCODE FLASHING. USE '▲' TO SELECT 1 st DIGIT OF CURRENT PASSWORD. USE '▼' TO MOVE TO NEXT DIGIT AND SET REST OF PASSCODE. | ✓ | UNIT RETURNS TO MENU MODE | | | | |

| | | | | | | |
|------------------|----|---|----|---|---|---|
| Forc Curr | ✓ | 'Forc' DISPLAYED WITH 'Icon' ICON. DEFAULT FORCE CURRENT '4.00' FLASHES. USE ▲▲ TO CHANGE TO REQUIRED mA LEVEL. | ✓ | UNIT TRANSMITS THE CURRENT IF YOU WANT TO EXIT FROM THIS MENU, USE ABORT FUNCTION | | |
| CAL Int3 | ✓ | 'Int' DISPLAYED WITH CURRENT CALIBRATION INTERVAL FLASHING. USE ▲▲ TO CHANGE INTERVAL. | ✓ | 'dUE' DISPLAYED AND 'No.' 'Lcd' OR 'ALL' FLASHING. USE ▲▲ TO SELECT REQUIRED CAL DUE WARNING OUTPUT. | UNIT RETURNS TO MENU MODE | |
| bump tEst | ✓ | PEAK READING DISPLAYED WITH OUTPUT INHIBITED 'Icon' ICON AND PEAK STRING FLASHING. APPLY BUMP TEST GAS AND CHECK PEAK READING ON DISPLAY. | ✓ | CURRENT GAS CONCENTRATION DISPLAYED WITH OUTPUT INHIBITED 'Icon' ICON FLASHING. | UNIT RETURNS TO MENU MODE WARNING; DO NOT RETURN TO NORMAL MODE UNTIL CURRENT GAS CONCENTRATION HAS FALLEN BELOW 10% OF THE DETECTOR WILL GIVE AN ALARM | |
| SEt ALrm | ✓ | 'AL1' ICON DISPLAYED AND CURRENT ALARM LEVEL 1 CONCENTRATION FLASHES. USE ▲▲ TO CHANGE TO REQUIRED CONCENTRATION LEVEL. | ✓ | 'AL1' DISPLAYED WITH 'None', 'rise' OR 'FALL' FLASHING. USE ▲▲ TO SELECT REQUIRED ALARM ACTION. | ✓ | 'AL2' DISPLAYED AND 'AL1' CONCENTRATION FLASHES. USE ▲▲ TO CHANGE TO REQUIRED CONCENTRATION LEVEL. |
| SEt rLY | ✓ | 'rL1' DISPLAYED AND 'AL1', 'AL2', 'Inht' OR 'FL1' FLASHES. USE ▲▲ TO CHANGE TO REQUIRED RELAY TARGET. | ✓ | 'rL1' DISPLAYED AND 'deen' OR 'Emr9' FLASHES. USE ▲▲ TO CHANGE TO REQUIRED RELAY ACTION. | ✓ | 'rL2' DISPLAYED AND 'AL1', 'AL2', 'Inht' OR 'FL1' FLASHES. USE ▲▲ TO CHANGE TO REQUIRED RELAY TARGET. |
| rLY OPr | ✓ | 'rL3' DISPLAYED AND 'AL1', 'AL2', 'Inht' OR 'FL1' FLASHES. USE ▲▲ TO CHANGE TO REQUIRED RELAY TARGET. | ✓ | 'rL3' DISPLAYED AND 'deen' OR 'Emr9' FLASHES. USE ▲▲ TO CHANGE TO REQUIRED RELAY ACTION. | UNIT RETURNS TO MENU MODE | |
| SEt Loc | ✓ | 'rLY', 'ON' DISPLAYED AND CURRENT RELAY-ON TIME FLASHES. USE ▲▲ TO CHANGE TO REQUIRED RELAY-ON DELAY. | ✓ | 'rLY', 'OFF' DISPLAYED AND CURRENT RELAY-OFF TIME FLASHES. USE ▲▲ TO CHANGE TO REQUIRED RELAY-OFF DELAY. | ✓ | 'Light' DISPLAYED AND 'YES' OR 'No' FLASHES. USE ▲▲ TO CHANGE TO REQUIRED LATCH OPTION. |
| tEmp Unit | ✓ | 'Loc' DISPLAYED WITH FIRST 4 CHARACTERS OF THE LOCATION STRING. USE ▼ TO CHANGE THE 1 ST CHARACTER OF CURRENT LOCATION STRING. USE ▲ TO MOVE TO NEXT CHARACTER AND SET REST OF STRING. MAXIMUM 12 CHARACTERS CAN BE SET. | ✓ | 'Loc' DISPLAYED NEW LOCATION STRING. THE STRING MOVES RIGHT-TO-LEFT TO SHOW WHOLE CHARACTERS TWICE. THEN UNIT AUTOMATICALLY RETURNS TO MENU MODE. | | |
| tEst ALrm | ✓ | 'Emp' DISPLAYED WITH 'C' OR 'F' FLASHING. USE ▲▲ TO CHANGE TO REQUIRED TEMPERATURE UNIT. | ✓ | UNIT RETURNS TO MENU MODE | | |
| SEt ID | ✓ | 'Forc' DISPLAYED AND 'AL1' FLASHING TO SELECT TEST-REQUIRED ALARM. USE ▼ TO FORCE ALARM. | ✓ | GAS NAME CURRENT GAS CONCENTRATION DISPLAYED AND 'Icon' ICON AND AL ICON FLASHING. | UNIT RETURNS TO MENU MODE | |
| 9ult | ✓ | SLAVE ID SHALL BE SET 1~247. USE ▲▲ TO CHANGE TO REQUIRED SLAVE No. OF UNIT. | | BAUD RATE SETTING 9600 OR 19200 USE ▲▲ TO CHANGE TO REQUIRED BAUD VALUE | PARTY SETTING (No, Even, Odd) USE ▲▲ TO CHANGE TO REQUIRED PARTY | Default are 19200m, Even PARITY |
| ▲▲ | OK | | ▲▲ | | | |
| ▲▲ | OK | | ▲▲ | | | |

¹ Refer to section 10.1 for detailed zero and span calibration procedures. A detector fitted with an oxygen sensor will skip the zeroing procedure. Re-calibrate the detector if left un-powered for periods in excess of 24 hours.
² This menu is only available and visible when the unit is fitted with flammable/IR sensor.
³ The calibration due warning counter is automatically reset after a successful calibration.

13.3 Sensor / Gas Selection

NOTE:

This Configuration option is not available for XCD units with EC sensors

13.3.1 Sensor Selection

“Select Sensor” sets the identity of the type of mV sensor attached to the XCD when XCD does not detect the sensor type automatically. when sensor type is detected by XCD automatically, the current sensor type can be confirmed in this menu.

The available mV sensors:

| | |
|------|---------------------------------------|
| Ir-1 | NDIR Infrared CO ₂ 0-2%Vol |
| Ir-3 | NDIR Infrared Methane 0-100%LEL |
| Ir-4 | NDIR Infrared Propane 0-100%LEL |
| Cb-1 | Catalytic 0-100%LEL |

13.3.2 Gas Selection

Use “SEL gAS” to set the target gas for sensors capable of detecting multiple gases. The available gases:

| Sensor type | Gas type | Gas Name displayed |
|-------------|-----------------|--------------------|
| Ir-1 | CO ₂ | CO ₂ |
| Ir-3 | mEt | mEt |
| Ir-4 | Propane | PrO |
| Cb-1 | Str1 to Str8 | FLM |

Gas selection is dependent on the type of sensor attached to the XCD. If Ir-1/Ir-3/Ir-4 sensor is attached, then gas type is detected by XCD automatically like CO₂/mEt/ProP gas. But when Cb-1 sensor is attached to the XCD, a user can select the gas from Str1 (1*) to Str8 (8*). For more information on star rating, please refer to section 19.2.

The current configuration of the XCD is displayed and by using the '✓' switch to enter "SEL gAS" menu. To select a flammable gas, use '▲▼' to move through the list, then use '✓' to make the selection or abort function to discard the selection and return to menu mode. If type of gas is changed, calibration prompt will appear to ask if you want to perform calibration.

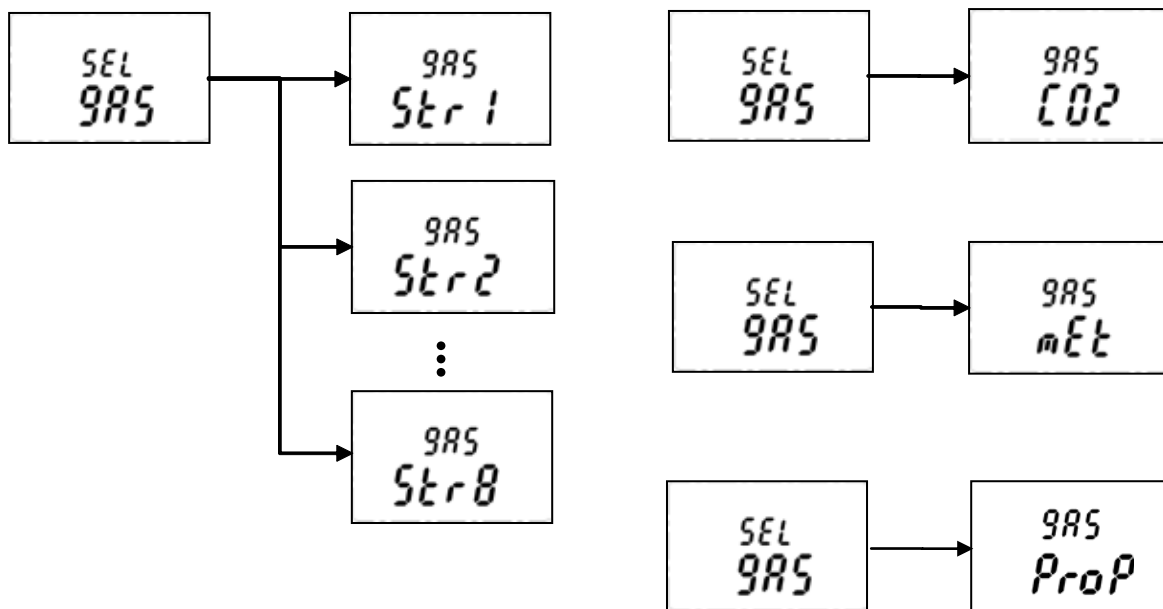

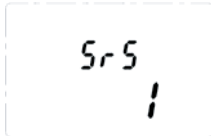





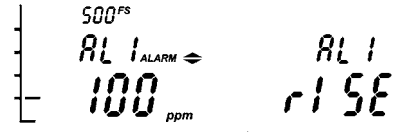
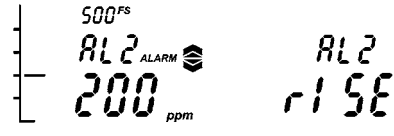

Diagram 16: Gas Selection

13.4 Review Mode

The instrument will enter Review mode when the “Enter” switch is activated with the Magnetic Wand and held for around one second.

Names, displays and descriptions for each review item in Review Mode are shown in the following table.

| Item name | Display | Description |
|-------------------|---|------------------------------------|
| Software version |  | S/W version of transmitter |
| SRS version |  | S/W version of SRS (watch dog) |
| EEP version |  | EEPROM parameter version |
| Gas |  | Gas type |
| Measuring range |  | A user selected measuring range |
| Calibration level |  | Calibration gas level |
| Calibration due |  | Estimated time to next calibration |
| Alarm 1 |  | Alarm settings for Alarm 1 |
| Alarm 2 |  | Alarm settings for Alarm 2 |





| | | |
|-------------|---|--|
| Location |  | Location in which the transmitter is installed |
| Power |  | Power voltage* |
| Temperature |  | Internal Transmitter temperature* |
| Peak conc. |  | Maximum concentration detected up to now |
| Test Result |  | There is no fault detected. |

Table 8: Transmitter menu descriptions

Note:

**Power voltage and internal transmitter temperature may be different from actual value due to measuring accuracy and internal heating components.*

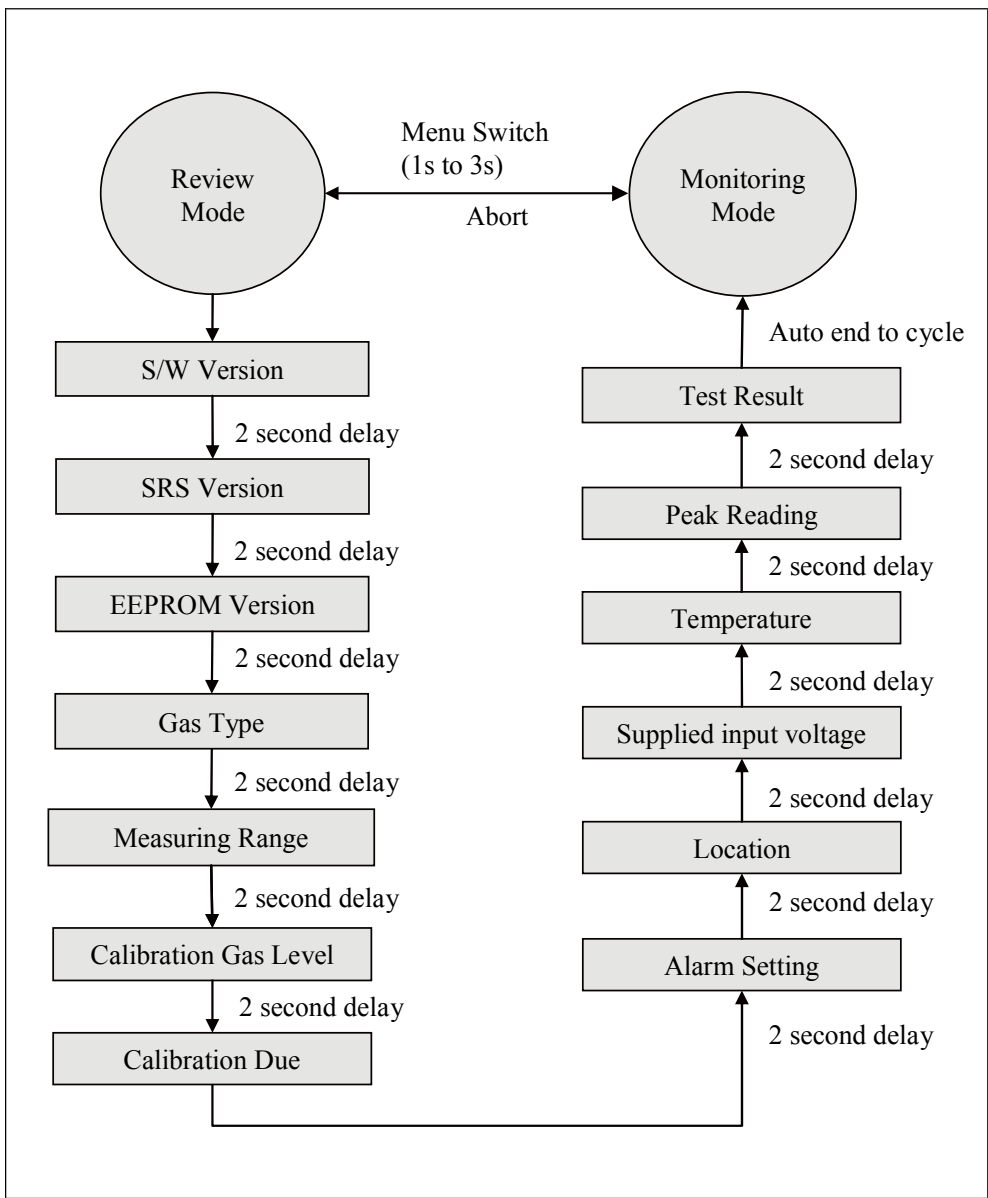

Diagram 17: Review Mode

14 General specification

| Sensepoint XCD Transmitter | | | | | | | | | | | |
|--|---|--|---------|--|-------------------|--------------------------|-------------------|------------------------|--------------|----------------------|------------|
| Use | | 3-wire, 4-20mA, gas detector transmitter for use with directly installed flammable and toxic gas sensors. For the protection of personnel and plant from flammable and toxic gas hazards. | | | | | | | | | |
| Electrical | | | | | | | | | | | |
| Input Voltage Range: | | 16 to 32Vdc (24Vdc nominal) | | | | | | | | | |
| Max Power Consumption: | | Max 5 Watts. at 24Vdc (see section 2 regarding maximum inrush current) | | | | | | | | | |
| Current output | | 4-20mA (Source or Sink) | | | | | | | | | |
| ≥0.0<1.0 mA | | Fault (refer to table 5 section 12.3 for further details). | | | | | | | | | |
| 4.0 mA to 20.0 mA | | Normal gas measurement | | | | | | | | | |
| 2.0 mA or 4.0 mA (17.4 mA) | | Inhibit (during configuration/user settings) | | | | | | | | | |
| 22.0 mA | | Maximum over range | | | | | | | | | |
| Terminals | | 15 x screw terminals suitable for wire diameter 0.5mm ² to 2.5mm ² (20AWG to 13AWG). | | | | | | | | | |
| Relays | | 3 x 5A@250VAC. Selectable normally open or normally closed (switch) and energized/de-energized (programmable). | | | | | | | | | |
| Communication | | RS485, Modbus RTU | | | | | | | | | |
| Construction | | | | | | | | | | | |
| Material | | Epoxy painted aluminium alloy or 316 Stainless Steel | | | | | | | | | |
| Weight | | Aluminium alloy: 1.7kg, 316 Stainless Steel: 3.7kg | | | | | | | | | |
| Mounting | | Pole or wall mounting | | | | | | | | | |
| Entries | | 2 x M20 (for ATEX/IECEX/AP Approval) or 2x3/4NPT (for UL Approval) | | | | | | | | | |
| Detectable Gases & Performance (See notes below) | | | | | | | | | | | |
| Gas | User Selectable Full Scale Range | Default Range | Steps | User Selectable Cal Gas Range | Default Cal Point | Response Time (T90) secs | Accuracy | Operating Temperature* | | Default alarm points | |
| | | | | | | | | Min | Max | A1 | A2 |
| Electrochemical Sensors | | | | | | | | | | | |
| Oxygen | 25.0% V/V only | 25.0% V/V | n/a | 20.9% V/V (Fixed) | 20.9% V/V | <30 | <+/-0.5% Vol. | -20°C / -4°F | 55°C / 131°F | 19.5V/V▼ | 23.5V/V▲ |
| Hydrogen Sulfide | 10.0 to 100.0ppm | 50.0ppm | 1.0ppm | | 25.0ppm | <50 | <+/-1ppm | -20°C / -4°F | 55°C / 131°F | 10.0ppm▲ | 20.0ppm▲ |
| Carbon Monoxide | 100 to 1,000ppm | 300ppm | 100ppm | 30 to 70% of selected full scale range | 100ppm | <30 | <+/-6ppm | -20°C / -4°F | 55°C / 131°F | 100ppm▲ | 200ppm▲ |
| Hydrogen | 1,000ppm only | 1,000ppm | n/a | | 500ppm | <65 | <+/-25ppm | -20°C / -4°F | 55°C / 131°F | 200ppm▲ | 400ppm▲ |
| Nitrogen Dioxide | 10.0 to 50.0 ppm | 10.0 ppm | 5.0 ppm | | 5.0 ppm | <40 | +/-3ppm or +/-20% | -20°C / -4°F | 55°C / 131°F | 5.0 ppm ▲ | 10.0 ppm▲ |
| Catalytic Bead Sensors | | | | | | | | | | | |
| Flammable 1 to 8* | 20 to 100% LEL | 100% LEL | 10% LEL | 25 to 95% of selected full scale range | 50% LEL | <25 | <+/-1.5% LEL | -20°C / -4°F | 55°C / 131°F | 20% LEL▲ | 40% LEL▲ |
| Infrared Sensors | | | | | | | | | | | |
| Methane | 20 to 100% LEL | 100% LEL | 10% LEL | 30 to 70% of selected full scale range | 50% LEL | <40 | <+/-1.5% LEL | -20°C / -4°F | 50°C / 122°F | 20% LEL▲ | 40% LEL▲ |
| Propane | 20 to 100% LEL | 100% LEL | 10% LEL | | 50% LEL | <40 | <+/-1.5% LEL | -20°C / -4°F | 50°C / 122°F | 20% LEL▲ | 40% LEL▲ |
| Carbon Dioxide | 2.00% Vol only | 2.00% V/V | n/a | | 1.00% V/V | <40 | <+/-2% Vol. | -20°C / -4°F | 50°C / 122°F | 0.40% V/V▲ | 0.80% V/V▲ |
| NOTES | | | | | | | | | | | |
| Performance figures are taken at 20~25°C; | | | | | | | | | | | |
| ▲ - Rising Alarm ▼ - Falling Alarm | | | | | | | | | | | |
| 1. measured using a sample humidity of 50%RH, applicable between 10 and 90% of full scale, | | | | | | | | | | | |
| 2. measured using test units calibrated at 50% of full scale, | | | | | | | | | | | |
| 3. measured at 1000cc/min for Methane CAT, 500cc/min for O ₂ , Toxic and Methane/Carbon Dioxide IR with calibration cup (S3KCAL). | | | | | | | | | | | |
| Response time (T90) may increase when operating in lower or higher temperature conditions or when gas is introduced with the Weather Protection accessory (SPXCDWP) fitted. Methane IR sensor is calibrated and linearised only for Methane. Should it be exposed to other HC then non linear response is expected. For linearised operation other than Methane contact HA for alternate parts. Flammable CAT and Methane IR is calibrated at the factory 50%LEL Methane (2.5%Vol). This calibration enables 100% functional test prior to dispatch. This calibration does not remove need for calibration & test as part of commissioning at site. For gases other than Methane the unit has to be calibrated at site using target gas. Data represents typical values, and system conditioning may be required to achieve stated result. Contact HA for details. | | | | | | | | | | | |
| * Extended operating temperature range of -40°C to +65°C (-40°F to +149°F) for all sensor except for IR and H2 EC sensors, with an accuracy of +/- 30% of applied gas from -20°C to -40°C (-4°F to -40°F) and +55°C to +65°C (+131°F to +149°F). Long term operation at this range may cause decline in sensor performance. | | | | | | | | | | | |
| Contact Honeywell Analytics for any additional data or details. | | | | | | | | | | | |
| Certification | | | | | | | | | | | |
| China | GB Ex d IIC T4 GB3836.1&2 -2000, PA, (CCCF – Pending) | | | | | | | | | | |
| Korea | KTL Ex d IIC T6 (-40°C to +65°C) | | | | | | | | | | |
| US | UL - Class I, Division 1, Groups B, C and D, Class I, Division 2, Groups B, C & D, Class II, Division, Groups E, F & G, Class II, Division 2, Groups F & G. -40°C to+65°C | | | | | | | | | | |
| European | ATEX Ex II 2 GD Ex d IIC Gb T6(Ta -40°C to +65°C) Ex tb IIIC T85°C Db IP66 | | | | | | | | | | |
| International | IEC Ex II 2 GD Ex d IIC Gb T6(Ta -40°C to +65°C) Ex tb IIIC T85°C Db IP66 | | | | | | | | | | |
| CE | EN50270:2006 EN6100-6-4:2007 | | | | | | | | | | |
| Environmental | | | | | | | | | | | |
| IP Rating | | IP66 in accordance with EN60529:1992 | | | | | | | | | |
| Operating Temperature | | -40°C to +65°C/ -40°F to +149°F, (IR: -20°C to +50°C/ -4°F to +122°F). Note: The detector display may become illegible at temperatures below -40°C, but the detector continues its gas monitoring function. The display is not damaged and recovers when the temperature rises back above -20 °C. | | | | | | | | | |
| Operating Humidity | | Continuous 20-90%RH (non condensing), Intermittent 10-99%RH (non condensing) | | | | | | | | | |
| Operating Pressure | | 90-110kPa | | | | | | | | | |
| Storage Conditions | | -25°C to +65°C (-13°F to +149°F) | | | | | | | | | |

15 Ordering information

| Part number | Description |
|---|---|
| Sensepoint XCD transmitter and sensor KIT (ATEX/IECEX/AP*, LM25 and M20 Entry) | |
| SPXCDALMFX | ATEX/IECEX/AP* Methane CAT 0-100%LEL (20,0 to 100.0%LEL, 10%LEL) with LM25, M20 Entry |
| SPXCDALMRX | ATEX/IECEX/AP* Methane IR 0-100%LEL (20,0 to 100.0%LEL, 10%LEL) with LM25, M20 Entry |
| SPXCDALMPX | ATEX/IECEX/AP* Propane IR 0-100%LEL (20,0 to 100.0%LEL, 10%LEL) with LM25, M20 Entry |
| SPXCDALMO1 | ATEX/IECEX/AP* Oxygen 25.0%/Vol with LM25, M20 Entry |
| SPXCDALMHX | ATEX/IECEX/AP* Hydrogen Sulfide 0-50ppm (10.0 to 100.0ppm, 1ppm) with LM25, M20 Entry |
| SPXCDALMCX | ATEX/IECEX/AP* Carbon Monoxide 0-500ppm (100 to 1000ppm, 100ppm) with LM25, M20 Entry |
| SPXCDALMG1 | ATEX/IECEX/AP* Hydrogen 0-1000ppm with LM25, M20 Entry |
| SPXCDALNNX | ATEX/IECEX/AP* Nitrogen Dioxide 0-50ppm with Aluminium alloy, M20 Entry |
| SPXCDALMB1 | ATEX/IECEX/AP* approved Carbon Dioxide IR 0-2.00%VOL with LM25, M20 Entry |
| Sensepoint XCD transmitter and sensor KIT (ATEX/IECEX/AP*, 316SS and M20 Entry) | |
| SPXCDASMFx | ATEX/IECEX/AP* approved Methane CAT 0-100%LEL (20 to 100%LEL, 10%LEL) with 316SS, M20 Entry |
| SPXCDASMRx | ATEX/IECEX/AP* approved Methane IR 0-100%LEL (20 to 100%LEL, 10%LEL) with 316SS, M20 Entry |
| SPXCDASMPx | ATEX/IECEX/AP* approved Propane IR 0-100%LEL (20 to 100%LEL, 10%LEL) with 316SS, M20 Entry |
| SPXCDASMO1 | ATEX/IECEX/AP* approved Oxygen 25.0%/Vol with 316SS, M20 Entry |
| SPXCDASMHx | ATEX/IECEX/AP* approved Hydrogen Sulfide 0-50ppm (10.0 to 100.0ppm, 1ppm) with 316SS, M20 Entry |
| SPXCDASMCx | ATEX/IECEX/AP* approved Carbon Monoxide 0-300ppm (100 to 1000ppm, 100ppm) with 316SS, M20 Entry |
| SPXCDASMG1 | ATEX/IECEX/AP* approved Hydrogen 0-1000ppm with 316SS, M20 Entry |
| SPXCDASNNx | ATEX/IECEX/AP* approved Nitrogen Dioxide 0-50ppm with SS316, M20 Entry |
| SPXCDASMB1 | ATEX/IECEX/AP* approved Carbon Dioxide IR 0-2.00%VOL with 316SS, M20 Entry |
| Sensepoint XCD transmitter and sensor KIT (UL, LM25 and 3/4"NPT Entry) | |
| SPXCDULNFX | UL/cUL approved Methane CAT 0-100%LEL (20 to 100%LEL, 10%LEL) with LM25, 3/4"NPT Entry |
| SPXCDULNRx | UL/cUL approved Methane IR 0-100%LEL (20 to 100%LEL, 10%LEL) with LM25, 3/4"NPT Entry |
| SPXCDULNPx | UL/cUL approved Propane IR 0-100%LEL (20 to 100%LEL, 10%LEL) with LM25, 3/4"NPT Entry |
| SPXCDULNO1 | UL/cUL approved Oxygen 25.0%/Vol with LM25, 3/4"NPT Entry |
| SPXCDULNHx | UL/cUL approved Hydrogen Sulfide 0-50ppm (10.0 to 100.0ppm, 1ppm) with LM25, 3/4"NPT Entry |
| SPXCDULNCx | UL/cUL approved Carbon Monoxide 0-300ppm (100 to 1000ppm, 100ppm) with LM25, 3/4"NPT Entry |
| SPXCDULNG1 | UL/cUL approved Hydrogen 0-1000ppm with LM25, 3/4"NPT Entry |
| SPXCDULNNx | UL approved SP XCD Nitrogen Dioxide 0-50ppm with LM25, 3/4"NPT Entry |
| SPXCDULNB1 | UL/cUL approved Carbon Dioxide IR 0-2.00%VOL with LM25, 3/4"NPT Entry |
| Sensepoint XCD transmitter and sensor KIT (UL, 316SS and 3/4"NPT Entry) | |
| SPXCDUSNFX | UL/cUL approved Methane CAT 0-100%LEL (20 to 100%LEL, 10%LEL) with 316SS, 3/4"NPT Entry |
| SPXCDUSNRx | UL/cUL approved Methane IR 0-100%LEL (20 to 100%LEL, 10%LEL) with 316SS, 3/4"NPT Entry |
| SPXCDUSNPx | UL/cUL approved Propane IR 0-100%LEL (20 to 100%LEL, 10%LEL) with 316SS, 3/4"NPT Entry |
| SPXCDUSNO1 | UL/cUL approved Oxygen 25.0%/Vol with 316SS, 3/4"NPT Entry |
| SPXCDUSNHx | UL/cUL approved Hydrogen Sulfide 0-50ppm (10.0 to 100.0ppm, 1ppm) with 316SS, 3/4"NPT Entry |
| SPXCDUSNCx | UL/cUL approved Carbon Monoxide 0-300ppm (100 to 1000ppm, 100ppm) with 316SS, 3/4"NPT Entry |
| SPXCDUSNG1 | UL/cUL approved Hydrogen 0-1000ppm with 316SS, 3/4"NPT Entry |
| SPXCDUSNNx | UL approved SP XCD Nitrogen Dioxide 0-50ppm with SS316, 3/4"NPT Entry |
| SPXCDUSNB1 | UL/cUL approved Carbon Dioxide IR 0-2.00%VOL with 316SS, 3/4"NPT Entry |
| Sensepoint XCD transmitter and sensor KIT (ATEX/IECEX/AP*, LM25 and M20 Entry with ModBus) | |

| | |
|--|--|
| SPXCDALMFXM | ATEX/IECEX/AP* Methane CAT 0-100%LEL (20,0 to 100.0%LEL, 10%LEL) with LM25, M20 Entry, with ModBus |
| SPXCDALMRXM | ATEX/IECEX/AP* Methane IR 0-100%LEL (20,0 to 100.0%LEL, 10%LEL) with LM25, M20 Entry, with ModBus |
| SPXCDALMPXM | ATEX/IECEX/AP* Propane IR 0-100%LEL (20,0 to 100.0%LEL, 10%LEL) with LM25, M20 Entry, with ModBus |
| SPXCDALMO1M | ATEX/IECEX/AP* Oxygen 25.0%/Vol with LM25, M20 Entry, with ModBus |
| SPXCDALMHXM | ATEX/IECEX/AP* Hydrogen Sulfide 0-50ppm (10.0 to 100.0ppm, 1ppm) with LM25, M20 Entry, with ModBus |
| SPXCDALMCXM | ATEX/IECEX/AP* Carbon Monoxide 0-500ppm (100 to 1000ppm, 100ppm) with LM25, M20 Entry, with ModBus |
| SPXCDALMG1M | ATEX/IECEX/AP* Hydrogen 0-1000ppm with LM25, M20 Entry, with ModBus |
| SPXCDALNXXM | ATEX/IECEX /AP approved Nitrogen Dioxide 0-50ppm with LM25, M20 Entry, With Modbus |
| SPXCDALMB1M | ATEX/IECEX/AP* approved Carbon Dioxide IR 0-2.00%VOL with LM25, M20 Entry, with ModBus |
| Sensepoint XCD transmitter and sensor KIT (ATEX/IECEX/AP*, 316SS and M20 Entry with ModBus) | |
| SPXCDASMF XM | ATEX/IECEX/AP* approved Methane CAT 0-100%LEL (20 to 100%LEL, 10%LEL) with 316SS, M20 Entry, with ModBus |
| SPXCDASMR XM | ATEX/IECEX/AP* approved Methane IR 0-100%LEL (20 to 100%LEL, 10%LEL) with 316SS, M20 Entry, with ModBus |
| SPXCDASMP XM | ATEX/IECEX/AP* approved Propane IR 0-100%LEL (20 to 100%LEL, 10%LEL) with 316SS, M20 Entry, with ModBus |
| SPXCDASMO1M | ATEX/IECEX/AP* approved Oxygen 25.0%/Vol with 316SS, M20 Entry, with ModBus |
| SPXCDASMHX M | ATEX/IECEX/AP* approved Hydrogen Sulfide 0-50ppm (10.0 to 100.0ppm, 1ppm) with 316SS, M20 Entry, with ModBus |
| SPXCDASMCX M | ATEX/IECEX/AP* approved Carbon Monoxide 0-300ppm (100 to 1000ppm, 100ppm) with 316SS, M20 Entry, with ModBus |
| SPXCDASMG1M | ATEX/IECEX/AP* approved Hydrogen 0-1000ppm with 316SS, M20 Entry, with ModBus |
| SPXCDASNXX M | ATEX/IECEX /AP approved Nitrogen Dioxide 0-50ppm with SS316, M20 Entry, With Modbus |
| SPXCDASMB1M | ATEX/IECEX/AP* approved Carbon Dioxide IR 0-2.00%VOL with 316SS, M20 Entry, with ModBus |
| UL APPROVAL (Epoxy Coated Aluminium Alloy, LM25, With Modbus) | |
| SPXCDULNFXM | UL/cUL approved Flammable CAT 0-100%LEL (20,0 to 100.0%LEL, 10%LEL) with LM25, 3/4"NPT Entry, with Modbus |
| SPXCDULNRXM | UL/cUL approved Methane IR 0-100%LEL (20,0 to 100.0%LEL, 10%LEL) with LM25, 3/4"NPT Entry, with Modbus |
| SPXCDULNPXM | UL/cUL approved Propane IR 0-100%LEL (20,0 to 100.0%LEL, 10%LEL) with LM25, 3/4"NPT Entry, with Modbus |
| SPXCDULNO1M | UL/cUL approved Oxygen 25.0%/Vol with LM25, 3/4"NPT Entry, with Modbus |
| SPXCDULNHXM | UL/cUL approved Hydrogen Sulfide 0-50ppm (10.0 to 100.0ppm, 1ppm) with LM25, 3/4"NPT Entry, with Modbus |
| SPXCDULNCXM | UL/cUL approved Carbon Monoxide 0-500ppm (100 to 1000ppm, 100ppm) with LM25, 3/4"NPT Entry, with Modbus |
| SPXCDULNG1M | UL/cUL approved Hydrogen 0-1000ppm with LM25, 3/4"NPT Entry, with Modbus |
| SPXCDULNXXM | UL/cUL approved Nitrogen Dioxide 0-50ppm with LM25, 3/4"NPT Entry, with Modbus |
| SPXCDULNB1M | UL/cUL approved Carbon Dioxide IR 0-2%VOL with LM25, 3/4"NPT Entry, with Modbus |
| UL APPROVAL (Epoxy Coated Stainless Steel, SS316, With Modbus) | |
| SPXCDUSNFXM | UL/cUL approved Flammable CAT 0-100%LEL (20,0 to 100.0%LEL, 10%LEL) with SS316, 3/4"NPT Entry, with Modbus |
| SPXCDUSNRXM | UL/cUL approved Methane IR 0-100%LEL (20,0 to 100.0%LEL, 10%LEL) with SS316, 3/4"NPT Entry, with Modbus |
| SPXCDUSNPXM | UL/cUL approved Propane IR 0-100%LEL (20,0 to 100.0%LEL, 10%LEL) with SS316, 3/4"NPT Entry, with Modbus |
| SPXCDUSNO1M | UL/cUL approved Oxygen 25.0%/Vol with SS316, 3/4"NPT Entry, with Modbus |
| SPXCDUSNHXM | UL/cUL approved Hydrogen Sulfide 0-50ppm (10.0 to 100.0ppm, 1ppm) with SS316, 3/4"NPT Entry, with Modbus |
| SPXCDUSNCXM | UL/cUL approved Carbon Monoxide 0-500ppm (100 to 1000ppm, 100ppm) with SS316, 3/4"NPT Entry, with Modbus |
| SPXCDUSNG1M | UL/cUL approved Hydrogen 0-1000ppm with SS316, 3/4"NPT Entry, with Modbus |
| SPXCDUSNXXM | UL/cUL approved Nitrogen Dioxide 0-50ppm with SS316, 3/4"NPT Entry, with Modbus |
| SPXCDUSNB1M | UL/cUL approved Carbon Dioxide IR 0-2%VOL with SS316, 3/4"NPT Entry, with Modbus |
| Replacement sensor cartridge | |
| SPXCDXSFXSS | Methane CAT 0-100%LEL (20,0 to 100.0%LEL, 10%LEL) |
| SPXCDXSRXSS | Methane IR 0-100%LEL (20,0 to 100.0%LEL, 10%LEL) |
| SPXCDXSPXSS | Propane IR 0-100%LEL (20,0 to 100.0%LEL, 10%LEL) |

| | |
|---|---|
| SPXCDXSO1SS | Oxygen 25.0%/Vol only |
| SPXCDXSHXSS | Hydrogen Sulfide 0-50ppm (10.0 to 100.0ppm, 1ppm) |
| SPXCDXSCXSS | Carbon Monoxide 0-500ppm (100 to 1000ppm, 100ppm) |
| SPXCDXSG1SS | Hydrogen 0-1000ppm only |
| SPXCDXSNXSS | Nitrogen Dioxide 0-10ppm (10.0 to 50.0ppm) |
| SPXCDXSB1SS | Carbon Dioxide IR 0-2.00%VOL only |
| Accessories | |
| S3KCAL | Calibration cap |
| SPXCDCC | Collecting cone for use with lighter than air gases |
| SPXCDDMK | Duct mounting kit |
| SPXCDHMANEN | Hard Copy Manual in English |
| SPXCDMTBR | Pipe Mounting bracket (inc. fixings and hex wrench set) |
| SPXCSDSP | Sunshade / Deluge Protection |
| SPXCDHMANEN | Hard Copy Manual in English |
| SPXCDHMANCN | Hard Copy Manual in Chinese |
| SPXCDHMANKR | Hard Copy Manual in Korean |
| Spares | |
| SPXCDDMT | Replacement display module (O2 & Toxic) |
| SPXCDDMF | Replacement display module (FL & IR) |
| SPXCDTMO | Replacement terminal module (O2) |
| SPXCDTMT | Replacement terminal module (Toxic) |
| SPXCDTMF | Replacement terminal module (FL & IR) |
| SPXCDMBUS | Replacement Modbus Module |
| SPXCDNPTP | 3/4"NPT Plug |
| SPXCDM20P | M20 Plug |
| SPXCDMANCD | Instruction manual CD |
| SPXCDNADP | 3/4"NPT to M20 Adaptor |
| SPXCDWP | Weather Protection |
| SPXCDMAG | Magnet |
| SPXCDSRLS | Sensor Retainer with locking screw |
| SPXCDAKS | Allen key for stopper |
| SPXCDHWES | Hex wrench for earth screw |
| SPXCDEBS | Earth Bracket and Screws |
| Special Flammable Gas Calibration | |
| SPXCDSFGC1 | Special Flammable Gas Calibration, 0-100%LEL, 1* |
| SPXCDSFGC2 | Special Flammable Gas Calibration, 0-100%LEL, 2* |
| SPXCDSFGC3 | Special Flammable Gas Calibration, 0-100%LEL, 3* |
| SPXCDSFGC4 | Special Flammable Gas Calibration, 0-100%LEL, 4* |
| SPXCDSFGC5 | Special Flammable Gas Calibration, 0-100%LEL, 5* |
| SPXCDSFGC7 | Special Flammable Gas Calibration, 0-100%LEL, 7* |
| SPXCDSFGC8 | Special Flammable Gas Calibration, 0-100%LEL, 8* |
| Note: If no Special Flammable Gas Calibration part no. is included on PO, a Methane (6* calibration will be supplied) | |

* AP approvals include GB & PA for China and KTL for Korea.

16 Warranty statement

All products are designed and manufactured to the latest internationally recognized standards by Honeywell Analytics under a Quality Management system that is certified to ISO 9001. As such Honeywell Analytics warrants its products against defective parts and workmanship and will repair or (at its option) replace any instruments which are or may become defective under proper use within 12 months from date of commissioning by an approved Honeywell Analytics representative or 18 months from date of shipment from Honeywell Analytics, whichever is the sooner. This warranty does not cover disposable batteries or damage caused by accident, abuse, abnormal operating conditions or poisoning of sensor.

Defective goods must be returned to Honeywell Analytics premises accompanied by a detailed description of any issue. Where return of goods is not practicable Honeywell Analytics reserves the right to charge for any site attendance where any fault is not found with the equipment. Honeywell Analytics shall not be liable for any loss or damage whatsoever or howsoever occasioned which may be a direct or indirect result of the use or operation of the Contract Goods by the Buyer or any Party.

This warranty covers instrument and parts sold to the Buyer only by authorized distributors, dealers and representatives as appointed by Honeywell Analytics. The warranties set out in this clause are not pro rata, i.e. the initial warranty period is not extended by virtue of any works carried out there under.

In no event will Honeywell Analytics be liable for any incidental damages, consequential damages, special damages, punitive damages, statutory damages, indirect damages, loss of profits, loss of revenues, or loss of use, even if informed of the possibility of such damages. Honeywell Analytics's liability for any claims arising out of or related to this product will in no case exceed the order value. To the extent permitted by applicable law, these limitations and exclusions will apply regardless of whether liability arises from breach of contract, warranty, tort (including but not limited to negligence), by operation of law, or otherwise.

17.2 Electronic Connection Drawing

3001G0471 SHT. 2

THIS DOCUMENT HAS BEEN GENERATED USING A4I.cCD
AND MUST ONLY BE UPDATED BY C.A.D

3 Wire 4~20mA (Source) with Relays

3 Wire 4~20mA (Sink) with Relays

| Terminal No. | Function |
|--------------|--------------------|
| 1 | +24V DC (16~32VDC) |
| 2 | 0V |
| 3 | 4~20 mA (signal) |
| 4 | Common |
| 5 | D1 ("B" / "+") |
| 6 | D0 ("A" / "-") |
| 7 | Relay |
| 8 | RLY1 NC |
| 9 | RLY1 COM |
| 10 | RLY1 NO |
| 11 | Relay |
| 12 | RLY2 NC |
| 13 | RLY2 COM |
| 14 | RLY2 NO |
| 15 | Relay |
| 16 | RLY3 NC |
| 17 | RLY3 COM |
| 18 | RLY3 NO |

NOTES:

- REFER TO INSTRUCTION MANUAL FOR TECHNICAL DETAILS.
- XCD OPERATING VOLTAGE 16~32Volts DC, 5W(Max)
- 4~20 mA LOOP RESISTANCE TO BE <300 ohms
- POWER SUPPLY LOOP RESISTANCE TO BE <12 ohm
- NO TWO 'EARTH POINTS' SHOULD BE CONNECTED VIA SCREEN AND/OR CONDUIT SO AS TO AVOID 'GROUND LOOPS'.
- MULTIPLE 'EARTH POINTS' ARE NOT ALLOWED.
- 'E' POINTS (CONTINUITY OF SCREEN) MAY BE ACHIEVED USING APPROPRIATE GLANDS/CABLE OR CONDUIT; INTERNAL AND EXTERNAL 'EARTH POINTS' IN THE TRANSMITTER ARE PROVIDED.
- XCD TRANSMITTER CERTIFICATION KTL : Ex d IIC T6 (Tamb. -40 °C to 65 °C)

THIS ITEM FORMS PART OF A CERTIFIED PRODUCT
NO MODIFICATION PERMITTED WITHOUT
REFERENCE TO CERTIFICATION DEPARTMENT

| SCALE | DRN | TITLE |
|-------|-----|--|
| NTS | BEN | Sensepoint XCD Installation Drawing |

| SCALE | DRN | TITLE |
|-------|-----|--|
| NTS | BEN | Sensepoint XCD Installation Drawing |

| MATERIAL | | FINISH | |
|----------|-----------|--------|-----------|
| G | 07/DEC/09 | F | 09/FEB/09 |
| H | 02/OCT/08 | G | 13/AUG/08 |
| I | 07/JUL/08 | H | 09/JUL/08 |
| J | 26/JUN/08 | I | 07/JUL/08 |
| K | 07/JUL/08 | J | 07/JUL/08 |
| L | 07/JUL/08 | K | 07/JUL/08 |
| M | 07/JUL/08 | L | 07/JUL/08 |
| N | 07/JUL/08 | M | 07/JUL/08 |
| O | 07/JUL/08 | N | 07/JUL/08 |
| P | 07/JUL/08 | O | 07/JUL/08 |
| Q | 07/JUL/08 | P | 07/JUL/08 |
| R | 07/JUL/08 | Q | 07/JUL/08 |
| S | 07/JUL/08 | R | 07/JUL/08 |
| T | 07/JUL/08 | S | 07/JUL/08 |
| U | 07/JUL/08 | T | 07/JUL/08 |
| V | 07/JUL/08 | U | 07/JUL/08 |
| W | 07/JUL/08 | V | 07/JUL/08 |
| X | 07/JUL/08 | W | 07/JUL/08 |
| Y | 07/JUL/08 | X | 07/JUL/08 |
| Z | 07/JUL/08 | Y | 07/JUL/08 |
| AA | 07/JUL/08 | Z | 07/JUL/08 |
| AB | 07/JUL/08 | AA | 07/JUL/08 |
| AC | 07/JUL/08 | AB | 07/JUL/08 |
| AD | 07/JUL/08 | AC | 07/JUL/08 |
| AE | 07/JUL/08 | AD | 07/JUL/08 |
| AF | 07/JUL/08 | AE | 07/JUL/08 |
| AG | 07/JUL/08 | AF | 07/JUL/08 |
| AH | 07/JUL/08 | AG | 07/JUL/08 |
| AI | 07/JUL/08 | AH | 07/JUL/08 |
| AJ | 07/JUL/08 | AI | 07/JUL/08 |
| AK | 07/JUL/08 | AJ | 07/JUL/08 |
| AL | 07/JUL/08 | AK | 07/JUL/08 |
| AM | 07/JUL/08 | AL | 07/JUL/08 |
| AN | 07/JUL/08 | AM | 07/JUL/08 |
| AO | 07/JUL/08 | AN | 07/JUL/08 |
| AP | 07/JUL/08 | AO | 07/JUL/08 |
| AQ | 07/JUL/08 | AP | 07/JUL/08 |
| AR | 07/JUL/08 | AQ | 07/JUL/08 |
| AS | 07/JUL/08 | AR | 07/JUL/08 |
| AT | 07/JUL/08 | AS | 07/JUL/08 |
| AU | 07/JUL/08 | AT | 07/JUL/08 |
| AV | 07/JUL/08 | AU | 07/JUL/08 |
| AW | 07/JUL/08 | AV | 07/JUL/08 |
| AX | 07/JUL/08 | AW | 07/JUL/08 |
| AY | 07/JUL/08 | AX | 07/JUL/08 |
| AZ | 07/JUL/08 | AY | 07/JUL/08 |
| BA | 07/JUL/08 | AZ | 07/JUL/08 |
| BB | 07/JUL/08 | BA | 07/JUL/08 |
| BC | 07/JUL/08 | BB | 07/JUL/08 |
| BD | 07/JUL/08 | BC | 07/JUL/08 |
| BE | 07/JUL/08 | BD | 07/JUL/08 |
| BF | 07/JUL/08 | BE | 07/JUL/08 |
| BG | 07/JUL/08 | BF | 07/JUL/08 |
| BH | 07/JUL/08 | BG | 07/JUL/08 |
| BI | 07/JUL/08 | BH | 07/JUL/08 |
| BJ | 07/JUL/08 | BI | 07/JUL/08 |
| BK | 07/JUL/08 | BJ | 07/JUL/08 |
| BL | 07/JUL/08 | BK | 07/JUL/08 |
| BM | 07/JUL/08 | BL | 07/JUL/08 |
| BN | 07/JUL/08 | BM | 07/JUL/08 |
| BO | 07/JUL/08 | BN | 07/JUL/08 |
| BP | 07/JUL/08 | BO | 07/JUL/08 |
| BQ | 07/JUL/08 | BP | 07/JUL/08 |
| BR | 07/JUL/08 | BQ | 07/JUL/08 |
| BS | 07/JUL/08 | BR | 07/JUL/08 |
| BT | 07/JUL/08 | BS | 07/JUL/08 |
| BU | 07/JUL/08 | BT | 07/JUL/08 |
| BV | 07/JUL/08 | BU | 07/JUL/08 |
| BW | 07/JUL/08 | BV | 07/JUL/08 |
| BX | 07/JUL/08 | BW | 07/JUL/08 |
| BY | 07/JUL/08 | BY | 07/JUL/08 |
| BZ | 07/JUL/08 | BZ | 07/JUL/08 |
| CA | 07/JUL/08 | CA | 07/JUL/08 |
| CB | 07/JUL/08 | CB | 07/JUL/08 |
| CC | 07/JUL/08 | CC | 07/JUL/08 |
| CD | 07/JUL/08 | CD | 07/JUL/08 |
| CE | 07/JUL/08 | CE | 07/JUL/08 |
| CF | 07/JUL/08 | CF | 07/JUL/08 |
| CG | 07/JUL/08 | CG | 07/JUL/08 |
| CH | 07/JUL/08 | CH | 07/JUL/08 |
| CI | 07/JUL/08 | CI | 07/JUL/08 |
| CJ | 07/JUL/08 | CJ | 07/JUL/08 |
| CK | 07/JUL/08 | CK | 07/JUL/08 |
| CL | 07/JUL/08 | CL | 07/JUL/08 |
| CM | 07/JUL/08 | CM | 07/JUL/08 |
| CN | 07/JUL/08 | CN | 07/JUL/08 |
| CO | 07/JUL/08 | CO | 07/JUL/08 |
| CP | 07/JUL/08 | CP | 07/JUL/08 |
| CQ | 07/JUL/08 | CQ | 07/JUL/08 |
| CR | 07/JUL/08 | CR | 07/JUL/08 |
| CS | 07/JUL/08 | CS | 07/JUL/08 |
| CT | 07/JUL/08 | CT | 07/JUL/08 |
| CU | 07/JUL/08 | CU | 07/JUL/08 |
| CV | 07/JUL/08 | CV | 07/JUL/08 |
| CU | 07/JUL/08 | CU | 07/JUL/08 |
| CV | 07/JUL/08 | CV | 07/JUL/08 |
| CW | 07/JUL/08 | CW | 07/JUL/08 |
| CX | 07/JUL/08 | CX | 07/JUL/08 |
| CY | 07/JUL/08 | CY | 07/JUL/08 |
| CZ | 07/JUL/08 | CZ | 07/JUL/08 |
| CA | 07/JUL/08 | CA | 07/JUL/08 |
| CB | 07/JUL/08 | CB | 07/JUL/08 |
| CC | 07/JUL/08 | CC | 07/JUL/08 |
| CD | 07/JUL/08 | CD | 07/JUL/08 |
| CE | 07/JUL/08 | CE | 07/JUL/08 |
| CF | 07/JUL/08 | CF | 07/JUL/08 |
| CG | 07/JUL/08 | CG | 07/JUL/08 |
| CH | 07/JUL/08 | CH | 07/JUL/08 |
| CI | 07/JUL/08 | CI | 07/JUL/08 |
| CJ | 07/JUL/08 | CJ | 07/JUL/08 |
| CK | 07/JUL/08 | CK | 07/JUL/08 |
| CL | 07/JUL/08 | CL | 07/JUL/08 |
| CM | 07/JUL/08 | CM | 07/JUL/08 |
| CN | 07/JUL/08 | CN | 07/JUL/08 |
| CO | 07/JUL/08 | CO | 07/JUL/08 |
| CP | 07/JUL/08 | CP | 07/JUL/08 |
| CQ | 07/JUL/08 | CQ | 07/JUL/08 |
| CR | 07/JUL/08 | CR | 07/JUL/08 |
| CS | 07/JUL/08 | CS | 07/JUL/08 |
| CT | 07/JUL/08 | CT | 07/JUL/08 |
| CU | 07/JUL/08 | CU | 07/JUL/08 |
| CV | 07/JUL/08 | CV | 07/JUL/08 |
| CW | 07/JUL/08 | CW | 07/JUL/08 |
| CX | 07/JUL/08 | CX | 07/JUL/08 |
| CY | 07/JUL/08 | CY | 07/JUL/08 |
| CZ | 07/JUL/08 | CZ | 07/JUL/08 |
| CA | 07/JUL/08 | CA | 07/JUL/08 |
| CB | 07/JUL/08 | CB | 07/JUL/08 |
| CC | 07/JUL/08 | CC | 07/JUL/08 |
| CD | 07/JUL/08 | CD | 07/JUL/08 |
| CE | 07/JUL/08 | CE | 07/JUL/08 |
| CF | 07/JUL/08 | CF | 07/JUL/08 |
| CG | 07/JUL/08 | CG | 07/JUL/08 |
| CH | 07/JUL/08 | CH | 07/JUL/08 |
| CI | 07/JUL/08 | CI | 07/JUL/08 |
| CJ | 07/JUL/08 | CJ | 07/JUL/08 |
| CK | 07/JUL/08 | CK | 07/JUL/08 |
| CL | 07/JUL/08 | CL | 07/JUL/08 |
| CM | 07/JUL/08 | CM | 07/JUL/08 |
| CN | 07/JUL/08 | CN | 07/JUL/08 |
| CO | 07/JUL/08 | CO | 07/JUL/08 |
| CP | 07/JUL/08 | CP | 07/JUL/08 |
| CQ | 07/JUL/08 | CQ | 07/JUL/08 |
| CR | 07/JUL/08 | CR | 07/JUL/08 |
| CS | 07/JUL/08 | CS | 07/JUL/08 |
| CT | 07/JUL/08 | CT | 07/JUL/08 |
| CU | 07/JUL/08 | CU | 07/JUL/08 |
| CV | 07/JUL/08 | CV | 07/JUL/08 |
| CW | 07/JUL/08 | CW | 07/JUL/08 |
| CX | 07/JUL/08 | CX | 07/JUL/08 |
| CY | 07/JUL/08 | CY | 07/JUL/08 |
| CZ | 07/JUL/08 | CZ | 07/JUL/08 |
| CA | 07/JUL/08 | CA | 07/JUL/08 |
| CB | 07/JUL/08 | CB | 07/JUL/08 |
| CC | 07/JUL/08 | CC | 07/JUL/08 |
| CD | 07/JUL/08 | CD | 07/JUL/08 |
| CE | 07/JUL/08 | CE | 07/JUL/08 |
| CF | 07/JUL/08 | CF | 07/JUL/08 |
| CG | 07/JUL/08 | CG | 07/JUL/08 |
| CH | 07/JUL/08 | CH | 07/JUL/08 |
| CI | 07/JUL/08 | CI | 07/JUL/08 |
| CJ | 07/JUL/08 | CJ | 07/JUL/08 |
| CK | 07/JUL/08 | CK | 07/JUL/08 |
| CL | 07/JUL/08 | CL | 07/JUL/08 |
| CM | 07/JUL/08 | CM | 07/JUL/08 |
| CN | 07/JUL/08 | CN | 07/JUL/08 |
| CO | 07/JUL/08 | CO | 07/JUL/08 |
| CP | 07/JUL/08 | CP | 07/JUL/08 |
| CQ | 07/JUL/08 | CQ | 07/JUL/08 |
| CR | 07/JUL/08 | CR | 07/JUL/08 |
| CS | 07/JUL/08 | CS | 07/JUL/08 |
| CT | 07/JUL/08 | CT | 07/JUL/08 |
| CU | 07/JUL/08 | CU | 07/JUL/08 |
| CV | 07/JUL/08 | CV | 07/JUL/08 |
| CW | 07/JUL/08 | CW | 07/JUL/08 |
| CX | 07/JUL/08 | CX | 07/JUL/08 |
| CY | 07/JUL/08 | CY | 07/JUL/08 |
| CZ | 07/JUL/08 | CZ | 07/JUL/08 |
| CA | 07/JUL/08 | CA | 07/JUL/08 |
| CB | 07/JUL/08 | CB | 07/JUL/08 |
| CC | 07/JUL/08 | CC | 07/JUL/08 |
| CD | 07/JUL/08 | CD | 07/JUL/08 |
| CE | 07/JUL/08 | CE | 07/JUL/08 |
| CF | 07/JUL/08 | CF | 07/JUL/08 |
| CG | 07/JUL/08 | CG | 07/JUL/08 |
| CH | 07/JUL/08 | CH | 07/JUL/08 |
| CI | 07/JUL/08 | CI | 07/JUL/08 |
| CJ | 07/JUL/08 | CJ | 07/JUL/08 |
| CK | 07/JUL/08 | CK | 07/JUL/08 |
| CL | 07/JUL/08 | CL | 07/JUL/08 |
| CM | 07/JUL/08 | CM | 07/JUL/08 |
| CN | 07/JUL/08 | CN | 07/JUL/08 |
| CO | 07/JUL/08 | CO | 07/JUL/08 |
| CP | 07/JUL/08 | CP | 07/JUL/08 |
| CQ | 07/JUL/08 | CQ | 07/JUL/08 |
| CR | 07/JUL/08 | CR | 07/JUL/08 |
| CS | 07/JUL/08 | CS | 07/JUL/08 |
| CT | 07/JUL/08 | CT | 07/JUL/08 |
| CU | 07/JUL/08 | CU | 07/JUL/08 |
| CV | 07/JUL/08 | CV | 07/JUL/08 |
| CW | 07/JUL/08 | CW | 07/JUL/08 |
| CX | 07/JUL/08 | CX | 07/JUL/08 |
| CY | 07/JUL/08 | CY | 07/JUL/08 |
| CZ | 07/JUL/08 | CZ | 07/JUL/08 |
| CA | 07/JUL/08 | CA | 07/JUL/08 |
| CB | 07/JUL/08 | CB | 07/JUL/08 |
| CC | 07/JUL/08 | CC | 07/JUL/08 |
| CD | 07/JUL/08 | CD | 07/JUL/08 |
| CE | 07/JUL/08 | CE | 07/JUL/08 |
| CF | 07/JUL/08 | CF | 07/JUL/08 |
| CG | 07/JUL/08 | CG | 07/JUL/08 |
| CH | 07/JUL/08 | CH | 07/JUL/08 |
| CI | 07/JUL/08 | CI | 07/JUL/08 |
| CJ | 07/JUL/08 | CJ | 07/JUL/08 |
| CK | 07/JUL/08 | CK | 07/JUL/08 |
| CL | 07/JUL/08 | CL | 07/JUL/08 |
| CM | 07/JUL/08 | CM | 07/JUL/08 |
| CN | 07/JUL/08 | CN | 07/JUL/08 |
| CO | 07/JUL/08 | CO | 07/JUL/08 |
| CP | 07/JUL/08 | CP | 07/JUL/08 |
| CQ | 07/JUL/08 | CQ | 07/JUL/08 |
| CR | 07/JUL/08 | CR | 07/JUL/08 |
| CS | 07/JUL/08 | | |

17.3 Duct Mounting Drawing

3001G0471 SHT. 3

I. ITEM LIST
1. DUCT MOUNTING PLATE

THIS DOCUMENT HAS BEEN GENERATED USING AutoCAD
AND MUST ONLY BE UPDATED BY C.A.D.

Honeywell

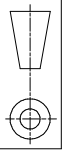

Duct Mounting Hole

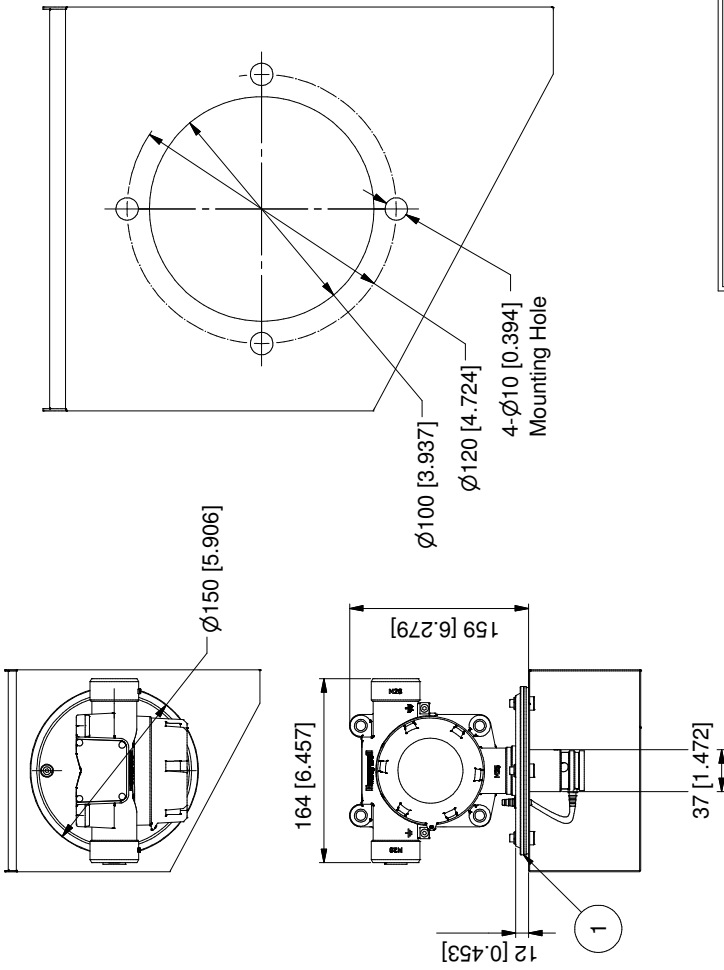

THIS ITEM FORMS PART OF A CERTIFIED PRODUCT
NO MODIFICATION PERMITTED WITHOUT
REFERENCE TO CERTIFICATION DEPARTMENT

| | | | | | | | |
|---|---------------|---|---------------|-----------------------------------|---------|--|-------|
| MATERIAL | | DR/N | | BEN | | 6/25/2008 | |
| FINISH | | NTS | | Sensepoint XCD | | Installation Drawing | |
| F | E | D | C | B | A | ISSUE | DATE |
| 09/FEB/09 | 02/OCT/08 | 13/AUG/08 | 09/JUL/08 | 07/JUL/08 | - | New Drawing | |
| J.Y.JIN | J.Y.JIN | J.Y.JIN | J.Y.JIN | J.Y.JIN | J.Y.JIN | Add Sheet | |
| J.Y.JIN | J.Y.JIN | J.Y.JIN | J.Y.JIN | J.Y.JIN | J.Y.JIN | Change WP | |
| J.Y.JIN | J.Y.JIN | J.Y.JIN | J.Y.JIN | J.Y.JIN | J.Y.JIN | App'D | |
| TOLERANCES TO BE AS SPECIFIED BELOW UNLESS OTHERWISE STATED. | | ALL DIMENSIONS IN MILLIMETRES UNLESS OTHERWISE STATED, AND APPLY AFTER PLATING. | | REMOVE ALL BURRS AND SHARP EDGES. | | SURFACE TEXTURE VALUES ARE IN µm Ra AND TO BS 1134 | |
| DIMS. | 2 DP ± 0.1 mm | 1 DP ± 0.25 mm | NONE ± 0.4 mm | ANGULAR ± 1/2° | ± 0.08 | ± 0.0 | ± 0.1 |
| HOLES. | Ø 0 to 8 | ± 0.0 | ± 0.0 | ± 0.0 | ± 0.12 | ± 0.12 | ± 0.0 |
| | Ø 8 to 14 | ± 0.0 | ± 0.0 | ± 0.0 | ± 0.12 | ± 0.12 | ± 0.0 |
| | Ø 14 to 25 | ± 0.0 | ± 0.0 | ± 0.0 | ± 0.0 | ± 0.0 | ± 0.0 |
| THIS DRAWING IS CONFIDENTIAL. IT IS THE PROPERTY OF HONEYWELL ANALYTICS LTD AND MUST NOT BE REPRODUCED EITHER WHOLLY OR PARTLY. ALL RIGHTS IN RESPECT OF PATENTS, DESIGNS AND COPYRIGHT ARE RESERVED. | | | | | | | |

17.4 Collecting Cone Drawing

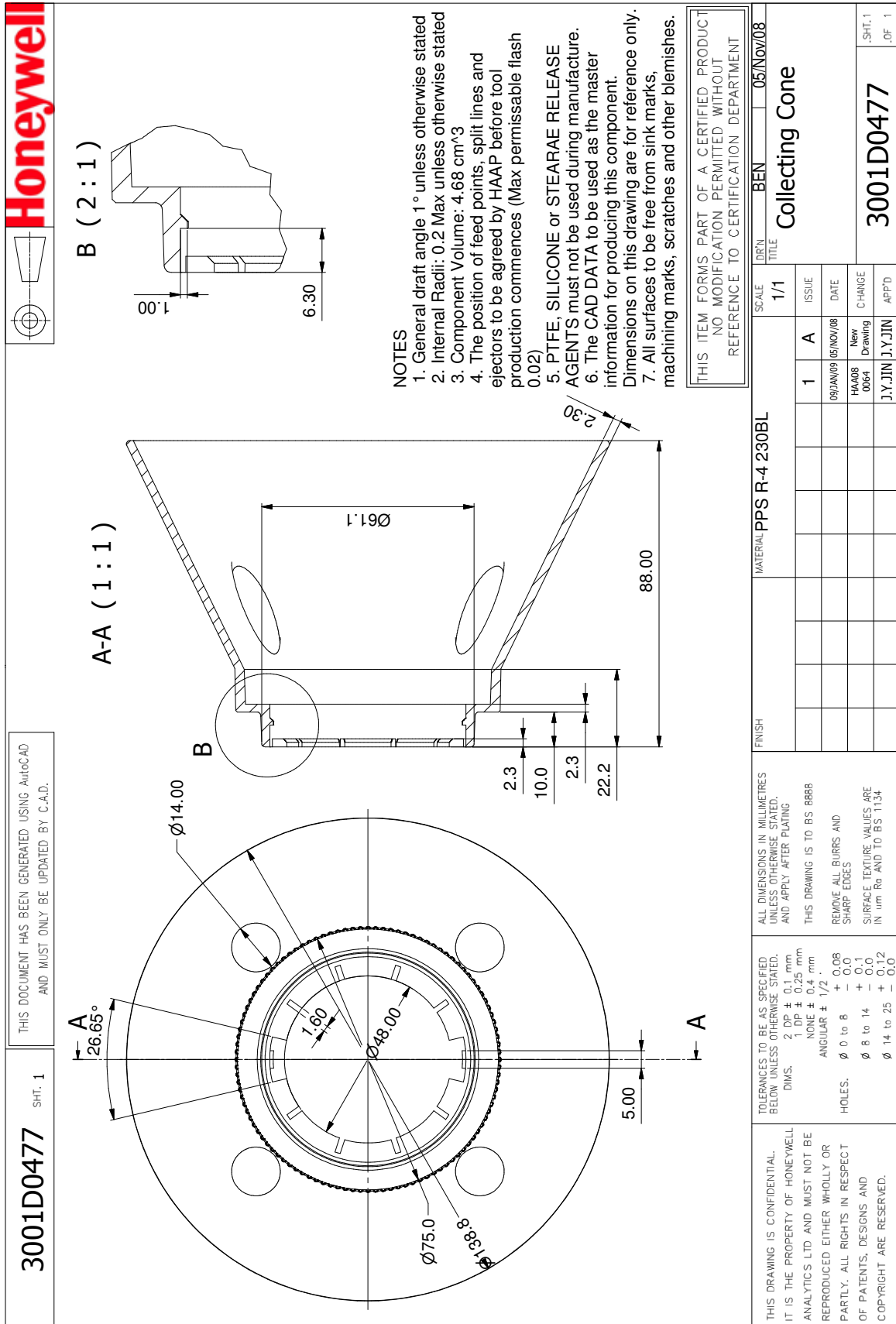

18 Certification

18.1 China GB Ex and PA

China GB Ex (Chinese Version):



防 爆 合 格 证

证号: GYJ081072X

由 **霍尼韦尔探测器亚太有限公司** 制造的产品:
(地址: 508 Korea Science Valley(H 187-10 Guro-dong, Guro-Gu Seoul, 152-050, Korea)

名 称 **可燃气体探测器**

型号规格 **Sensepoint XCD**

防爆标志 **Ex d IIC T4**

产品标准 /

图样编号 **3001EG026、3001EG027**

经图样及技术文件的审查和样品检验, 确认上述产品符合 **GB 3836.1-2000、GB 3836.2-2000** 标准, 特颁发此证。有效期自颁发日期起 **伍** 年内有效。

备注 产品使用安全注意事项见防爆合格证附件 I。

站长 

国家级仪器仪表防爆安全监督检验站

颁发日期 **二〇〇八** 年 **七** 月 **十五** 日

本证书仅对与认可文件和样品一致的产品有效。

| | | |
|----------------|--------------------------|----------------------|
| 地址: 上海市灵石路103号 | 网址: www.nepsi.org.cn | 电话: 0086 21 64568180 |
| 邮编: 200233 | Email: info@nepsi.org.cn | 传真: 0086 21 64544580 |

China GB Ex (English Version):

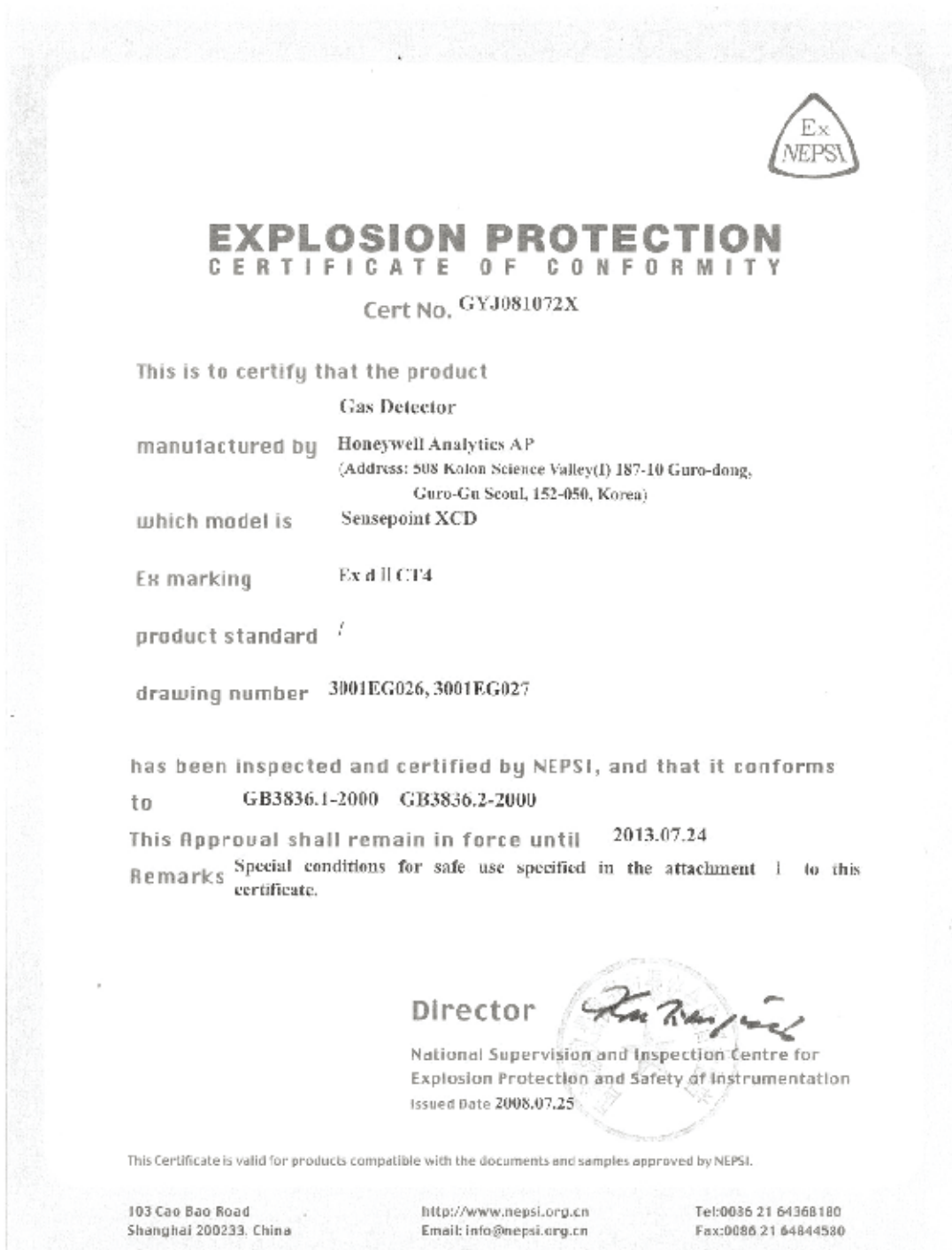

China PA Certification:

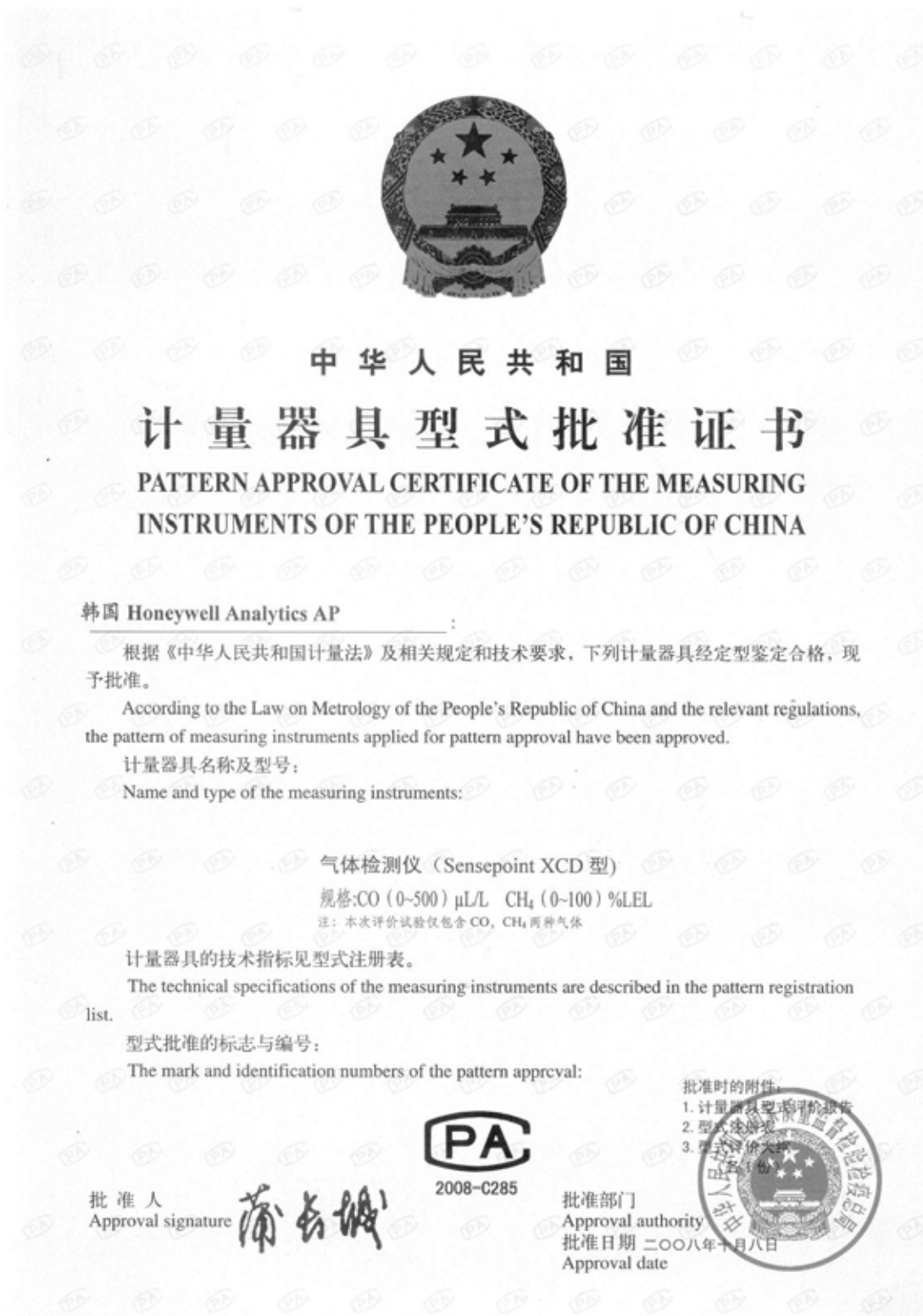

中华人民共和国

计量器具型式批准证书

PATTERN APPROVAL CERTIFICATE OF THE MEASURING INSTRUMENTS OF THE PEOPLE'S REPUBLIC OF CHINA

韩国 Honeywell Analytics AP _____ :

根据《中华人民共和国计量法》及相关规定和技术要求，下列计量器具经定型鉴定合格，现予批准。

According to the Law on Metrology of the People's Republic of China and the relevant regulations, the pattern of measuring instruments applied for pattern approval have been approved.

计量器具名称及型号:

Name and type of the measuring instruments:

气体检测仪 (Sensepoint XCD 型)

规格:CO (0-500) μL/L CH₄ (0-100) %LEL

注: 本次评价试验仅包含 CO, CH₄ 两种气体

计量器具的技术指标见型式注册表。

The technical specifications of the measuring instruments are described in the pattern registration list.

型式批准的标志与编号:

The mark and identification numbers of the pattern approval:

批准人
Approval signature



2008-C285

批准部门
Approval authority
批准日期 二〇〇八年十月八日
Approval date

批准时的附件:

- 1. 计量器具型式评价报告
- 2. 型式注册表
- 3. 型式评价大纲



18.2 Korea KTL

kti 한국산업기술시험원
Korea Testing Laboratory

CERTIFICATE OF APPROVAL

Ref. Cert. No.
2008-1148-Q1

- 1 This certificate is issued for the equipment;
Fixed Gas Detector
Model : Sensepoint XCD
[16~32VDC, Max. 5W]
- 2 Manufactured and submitted for certification by;
Honeywell Analytics
#508, Kolon Science Valley(I)
187-70 Guro-Dong, Guro-Gu, Seoul, 152-050, Korea
- 3 This equipment and any acceptable variation thereto are specified in the schedule to this certificate and the test report therein referred to.
- 4 KTL, being an Approved Certification Body in accordance with Article 33 of the Industrial Safety and Health Law and Article 27 of Enforcement Ordinance, Article 46 of Detailed Enforcement Regulation of the Law, confirms that the apparatus has been found to comply with the following Korean Standards;
Presidential Decree No. 2003-18 (Ministry of Labor)
 and has successfully met the examination and test requirements recorded in confidential report number;
KTL Test Report No. 1454-169-2008
- 5 The code for the electrical apparatus is;
Ex d IIC T6 (-40 °C ... +65 °C)
- 6 This equipment may be marked Designated Mark specified in Article 46-7 of Detailed Enforcement Regulation of the Industrial Safety & Health Law.
- 7 The validity of this certificate is until 23 April 2013.

Seoul, 24 June 2008

 Approved by
 Jun-gu, Kang

KOREA TESTING LABORATORY

Page 1/1

FP251-03 152-718 서울특별시 구로구 구로동 222-13 <http://www.ktl.re.kr>

18.3 European ATEX

ATEX For Transmitter:

Certificate Number
Baseefa08ATEX0222



Issued 31 October 2008
Page 1 of 2

1 **EC - TYPE EXAMINATION CERTIFICATE**

2 **Equipment or Protective System Intended for use in Potentially Explosive Atmospheres
Directive 94/9/EC**

3 EC - Type Examination Certificate Number: **Baseefa08ATEX0222**

4 Equipment or Protective System: **A Type XCD Transmitter**

5 Manufacturer: **Honeywell Analytics**

6 Address: **405 Barclay Boulevard, Lincolnshire, IL 60069, USA.**

7 This equipment or protective system and any acceptable variation thereto is specified in the schedule to this certificate and the documents therein referred to.

8 Baseefa, Notified Body number 1180, in accordance with Article 9 of the Council Directive 94/9/EC of 23 March 1994, certifies that this equipment or protective system has been found to comply with the Essential Health and Safety Requirements relating to the design and construction of equipment and protective systems intended for use in potentially explosive atmospheres given in Annex II to the Directive.

The examination and test results are recorded in confidential Report No. **GB/BAS/ExTR08.0149/00**

9 Compliance with the Essential Health and Safety Requirements has been assured by compliance with:

IEC60079-0: 2007 EN60079-1: 2007 EN 61241-1: 2006

except in respect of those requirements listed at item 18 of the Schedule.

10 If the sign "X" is placed after the certificate number, it indicates that the equipment or protective system is subject to special conditions for safe use specified in the schedule to this certificate.

11 This EC - TYPE EXAMINATION CERTIFICATE relates only to the design and construction of the specified equipment or protective system. Further requirements of the Directive apply to the manufacturing process and supply of this equipment or protective system. These are not covered by this certificate.

12 The marking of the equipment or protective system shall include the following :

Ex II GD Ex d IIC Gb T6 (Ta -40°C to +65°C) Ex tb IIC T85°C Db IP66

This certificate may only be reproduced in its entirety, without any change, schedule included.

Baseefa Customer Reference No. **5989**

Project File No. **08/0201**

This certificate is granted subject to the general terms and conditions of Baseefa. It does not necessarily indicate that the equipment may be used in particular industries or circumstances.

Baseefa
Rockhead Business Park, Staden Lane,
Buxton, Derbyshire SK17 9RZ
Telephone +44 (0) 1298 766600 Fax +44 (0) 1298 766601
e-mail info@baseefa.com web site www.baseefa.com
Baseefa is a trading name of Baseefa Ltd
Registered in England No. 4305578. Registered address as above.

DBewley
PP DISCREPANCIES
R S SINCLAIR
DIRECTOR
On behalf of
Baseefa

ATEX for Sensor

Certificate Number
Baseefa08ATEX0316X



Issued 9 March 2009
Page 1 of 2

EC - TYPE EXAMINATION CERTIFICATE

Equipment or Protective System Intended for use in Potentially Explosive Atmospheres
Directive 94/9/EC

EC - Type Examination Certificate Number: **Baseefa08ATEX0316X**

Equipment or Protective System: **A Type XCD Gas Sensor Head**

Manufacturer: **Honeywell Analytics Inc.**

Address: **405 Barclay Boulevard, Lincolnshire, IL 60069, USA.**

This equipment or protective system and any acceptable variation thereto is specified in the schedule to this certificate and the documents therein referred to.

Baseefa, Notified Body number 1180, in accordance with Article 9 of the Council Directive 94/9/EC of 23 March 1994, certifies that this equipment or protective system has been found to comply with the Essential Health and Safety Requirements relating to the design and construction of equipment and protective systems intended for use in potentially explosive atmospheres given in Annex II to the Directive.

The examination and test results are recorded in confidential Report No. **GB/BAS/ExTR08.0220/00**

Compliance with the Essential Health and Safety Requirements has been assured by compliance with:

IEC 60079-0: 2007

EN 60079-1: 2007

EN 61241-1: 2004

except in respect of those requirements listed at item 18 of the Schedule.

If the sign "X" is placed after the certificate number, it indicates that the equipment or protective system is subject to special conditions for safe use specified in the schedule to this certificate.

This EC - TYPE EXAMINATION CERTIFICATE relates only to the design and construction of the specified equipment or protective system. Further requirements of the Directive apply to the manufacturing process and supply of this equipment or protective system. These are not covered by this certificate.

The marking of the equipment or protective system shall include the following :

Ⓔ II 2 GD Ex d IIC T6 (Ta -40°C to +65°C) Gb Ex tb IIIC T85°C Db IP6X A21

This certificate may only be reproduced in its entirety, without any change, schedule included.

Baseefa Customer Reference No. **5989**

Project File No. **08/0261**

This certificate is granted subject to the general terms and conditions of Baseefa. It does not necessarily indicate that the equipment may be used in particular industries or circumstances.



Baseefa

Rockhead Business Park, Staden Lane,
Buxton, Derbyshire SK17 9RZ
Telephone +44 (0) 1298 766600 Fax +44 (0) 1298 766601
e-mail info@baseefa.com web site www.baseefa.com
Baseefa is a trading name of Baseefa Ltd
Registered in England No. 4305576. Registered address as above.

R S SINCLAIR
DIRECTOR
On behalf of
Baseefa

18.4 International IEC

IEC Ex for Transmitter

| | | | |
|---|---|--|---|
|  | | <h1>IECEX Certificate of Conformity</h1> | |
| <p>INTERNATIONAL ELECTROTECHNICAL COMMISSION IEC Certification Scheme for Explosive Atmospheres <small>for rules and details of the IECEx Scheme visit www.iecex.com</small></p> | | | |
| Certificate No.: | IECEX BAS 08.0072 | issue No.:1 | Certificate history: Issue No. 1 (2009-12-8) Issue No. 0 (2008-11-10) |
| Status: | Current | | |
| Date of Issue: | 2009-12-08 | Page 1 of 4 | |
| Applicant: | Honeywell Analytics 405 Barclay Boulevard Lincolnshire Illinois 60069 United States of America | | |
| Electrical Apparatus: | A Type XCD Transmitter | | |
| <i>Optional accessory:</i> | | | |
| Type of Protection: | Flameproof | | |
| Marking: | Ex d IIC Gb T6 (Ta -40°C to +65°C) Ex tb IIC T85°C Db IP66 | | |
| Approved for issue on behalf of the IECEx Certification Body: | R S Sinclair | | |
| Position: | Managing Director | | |
| Signature: <i>(for printed version)</i> | _____ | | |
| Date: | _____ | | |
| 1. This certificate and schedule may only be reproduced in full. 2. This certificate is not transferable and remains the property of the issuing body. 3. The Status and authenticity of this certificate may be verified by visiting the Official IECEx Website. | | | |
| Certificate issued by: <div style="display: flex; justify-content: space-between; align-items: center; margin-top: 10px;"> <div style="text-align: center;"> <p>Baseefa Rockhead Business Park Staden Lane Buxton Derbyshire SK17 9RZ United Kingdom</p> </div> <div style="text-align: center;">  </div> </div> | | | |

IEC Ex for Sensor

| | | | |
|---|---|--|---|
|  | | <h1 style="margin: 0;">IECEX Certificate of Conformity</h1> | |
| <p>INTERNATIONAL ELECTROTECHNICAL COMMISSION IEC Certification Scheme for Explosive Atmospheres <small>for rules and details of the IECEx Scheme visit www.iecex.com</small></p> | | | |
| Certificate No.: | IECEX BAS 08.0104X | Issue No.: | 0 |
| Status: | Current | | |
| Date of Issue: | 2009-03-09 | Page 1 of 3 | |
| Applicant: | Honeywell Analytics 405 Barclay Boulevard Lincolnshire Illinois 60069 United States of America | | |
| Electrical Apparatus: | A Type XCD Gas Sensor Head | | |
| Optional accessory: | | | |
| Type of Protection: | Flameproof and Dust | | |
| Marking: | Ex d IIC T6 (Ta -40°C to +65°C) Gb Ex tb IIIC T85°C Db IP6X A21 | | |
| Approved for issue on behalf of the IECEx Certification Body: | R S Sinclair | | |
| Position: | Managing Director | | |
| Signature: (for printed version) |  | | |
| Date: | 10-3-09 | | |
| 1. This certificate and schedule may only be reproduced in full. 2. This certificate is not transferable and remains the property of the issuing body. 3. The Status and authenticity of this certificate may be verified by visiting the Official IECEx Website . | | | |
| Certificate issued by: | | | |
| <p>Baseefa Rockhead Business Park Staden Lane Buxton Derbyshire SK17 9RZ United Kingdom</p> | |  | |

18.7 Sensepoint XCD Warning Tag

3001EU048

SHT. 1

THIS DOCUMENT HAS BEEN GENERATED USING AutoCAD
AND MUST ONLY BE UPDATED BY C.A.D.

FRONT

BACK

NOTES:

- 1.The surface shall be flat and the words be readable,
- 2.The shall be no burr around.
- 3.Etching depth:0.1mm
- 4.TEXT ON BOTH SIDES OF LABEL

THIS ITEM FORMS PART OF A CERTIFIED PRODUCT
NO MODIFICATION PERMITTED WITHOUT
REFERENCE TO CERTIFICATION DEPARTMENT

| | | | | | | |
|----------|-------------------------|-------------|----------|-------------|-----|-----------|
| MATERIAL | BS970:PART3:1991:316S11 | SCALE | 1/1 | DRN | BEN | 22/SEP/08 |
| FINISH | | ISSUE | A | TITLE | | |
| | | DATE | 20/07/08 | TRANSMITTER | | |
| | | CHANGE P/N | NEW | WARNING_TAG | | |
| | | APPROVED BY | J.Y.JIN | | | |
| | | | | 3001EU048 | | |
| | | | | SHT. 1 OF 1 | | |

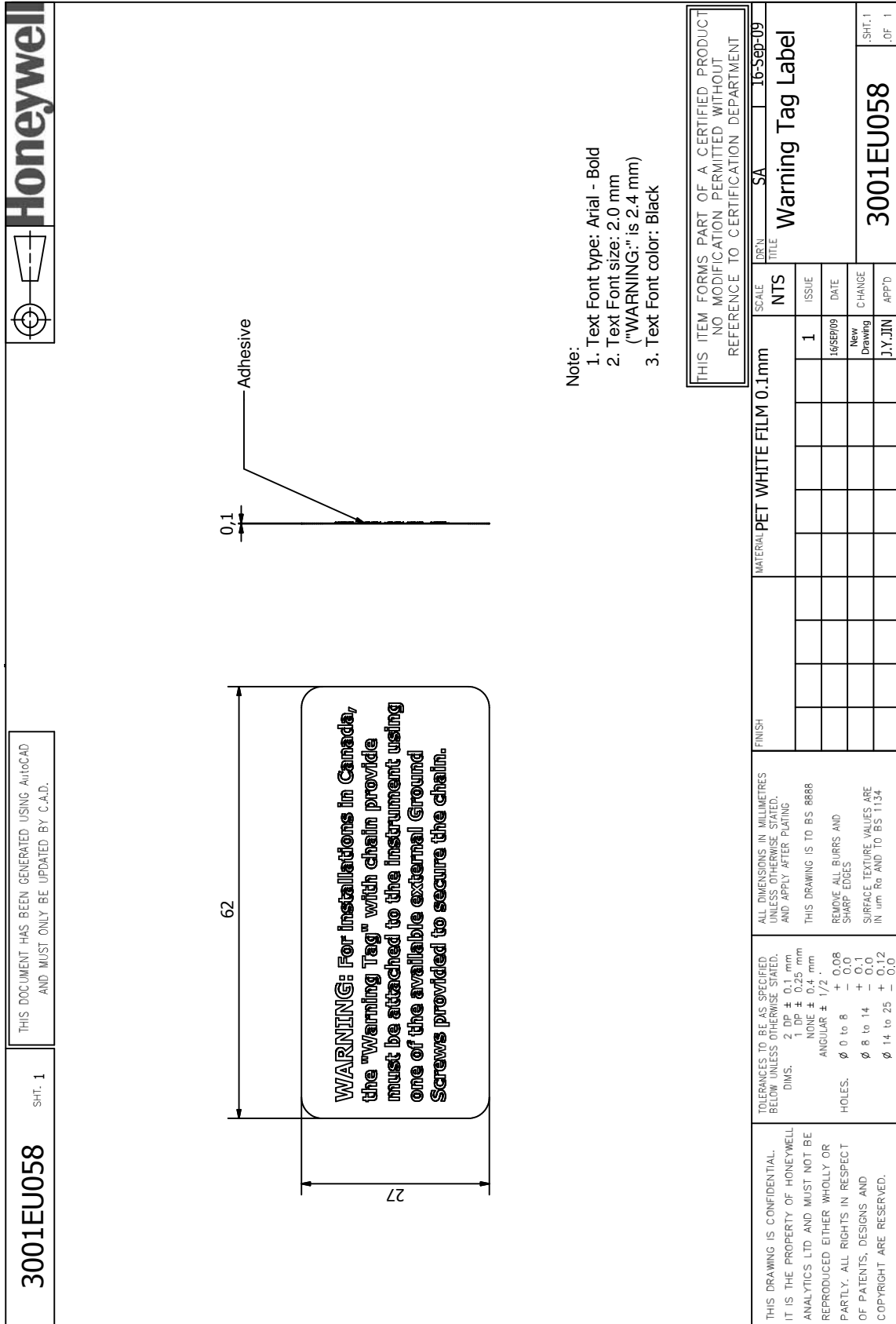

19 Cross Interference and Cross Calibration

19.1 Cross Interference Table for Toxic and Oxygen

This table shows the relative cross sensitivity of the Sensepoint XCD to other gases. “Gas Type” indicated the XCD sensor type fitted to the XCD. “Gas Type Applied” indicates the gas that may be applied to that sensor and the resulting Reading.

| Gas type | Gas Type Applied | Concentration | Unit | Reading | Unit |
|------------------|-------------------|---------------|------|--------------------|---|
| O ₂ | Carbon Dioxide | 5 | %vol | 0.1 | %vol (change O ₂ reading) per %vol CO ₂ |
| H ₂ S | Ammonia | 50 | ppm | 0 | ppm H ₂ S |
| | Carbon Monoxide | 100 | ppm | <2 | ppm H ₂ S |
| | Carbon Dioxide | 5000 | ppm | 0 | ppm H ₂ S |
| | Chlorine | 0.5 | ppm | 0 | ppm H ₂ S |
| | Ethylene | 100 | ppm | 0 | ppm H ₂ S |
| | Hydrogen | 100 | ppm | 0 | ppm H ₂ S |
| | Hydrogen Sulfide | 10 | ppm | 10 | ppm H ₂ S |
| | Nitrogen Monoxide | 25 | ppm | 0 | ppm H ₂ S |
| | Nitrogen Dioxide | 3 | ppm | 0 | ppm H ₂ S |
| | Sulfur Dioxide | 2 | ppm | 0 | ppm H ₂ S |
| CO | Acetone | 1000 | ppm | 0 | ppm CO |
| | Acetylene | 40 | ppm | 80 | ppm CO |
| | Ammonia | 100 | ppm | 0 | ppm CO |
| | Carbon Monoxide | 100 | ppm | 100 | ppm CO |
| | Chlorine | 2 | ppm | 0 | ppm CO |
| | Ethanol | 2000 | ppm | 3 | ppm CO |
| | Ethylene | 100 | ppm | 85 | ppm CO |
| | Hydrogen | 100 | ppm | 20 | ppm CO |
| | Hydrogen | 25 | ppm | 0 | ppm CO |
| | Iso-Propanol | 200 | ppm | 0 | ppm CO |
| | Nitrogen Monoxide | 50 | ppm | 8 | ppm CO |
| | Nitrogen Dioxide | 800 | ppm | 20 | ppm CO |
| | Sulfur Dioxide | 50 | ppm | 0.5 | ppm CO |
| H ₂ | Carbon Monoxide | 300 | ppm | ≤60 | ppm H ₂ |
| | Hydrogen Sulfide | 15 | ppm | <3 | ppm H ₂ |
| | Sulfur Dioxide | 5 | ppm | 0 | ppm H ₂ |
| | Nitrogen Monoxide | 35 | ppm | »10 | ppm H ₂ |
| | Nitrogen Dioxide | 5 | ppm | 0 | ppm H ₂ |
| | Chlorine | 1 | ppm | 0 | ppm H ₂ |
| | Hydrogen Cyanide | 10 | ppm | »3 | ppm H ₂ |
| | Hydrogen Chloride | 5 | ppm | 0 | ppm H ₂ |
| Ethylene | 100 | ppm | »80 | ppm H ₂ | |

19.2 Cross Calibration Flammable Gas Detector

For greater accuracy, a catalytic gas detector should be calibrated using a certified gas/air mixture equal to 50% LEL of the actual target gas intended to be monitored.

However, it is not always practical to obtain every detectable type of hydrocarbon gas in a calibration-ready, certified and verifiable form. Therefore, it is possible to carry out a “cross calibration” using another hydrocarbon gas/air mixture.

When the Sensepoint XCD Combustible LEL sensor is to be calibrated with a gas which is different to the gas or vapour to be detected, the following cross calibration procedure may be followed:

Caution: Where the user calibrates any sensor using a different gas, responsibility for identifying and recording calibration rests with the user. Refer to the local regulations where appropriate.

Notes:

1. Table 11 lists a selection of hydrocarbon compounds and states a reference figure or “Star Rating” according to the reaction they produce in relation to other hydrocarbons.
2. An eight star (8*) gas produces the highest output, while a one star (1*) gas produces the lowest output.

| No. | Gas | Star Rating |
|-----|----------------|-------------|
| 1 | Acetone | 4* |
| 2 | Ammonia | 7* |
| 3 | Benzene | 3* |
| 4 | Butanone | 3* |
| 5 | Butane | 4* |
| 6 | Butyl acetate | 2* |
| 7 | Butyl acrylate | 2* |
| 8 | Cyclohexane | 3* |
| 9 | Cyclohexanone | <1* |
| 10 | Diethyl ether | 4* |
| 11 | Ethane | 6* |
| 12 | Ethanol | 5* |
| 13 | Ethyl acetate | 3* |
| 14 | Ethylene | 6* |
| 15 | Heptane | 3* |
| 16 | Hexane | 4* |
| 17 | Hydrogen | 6* |
| 18 | Methane | 7* |
| 19 | Methanol | 5* |
| 20 | MIBK | 2* |
| 21 | Octane | 3* |
| 22 | Pentane | 4* |
| 23 | Propane | 5* |

| | | |
|----|------------------|----|
| 24 | Propan-2-ol | 4* |
| 25 | Styrene | 1* |
| 26 | Tetra hydrafuran | 4* |
| 27 | Toluene | 3* |
| 28 | Triethylamine | 3* |
| 29 | Xylene | 1* |

Table 14 . Star Rating of Gases

To cross calibrate the SG16B flammable gas detector catalytic bead:

(1) Obtain the star rating for both the calibration test gas and the gas to be detected from Table 14

(2) These values may then be used in Table 15 to obtain the required calibration span setting when a 50% LEL test gas is applied to the detector.

| *Rating of Calibration Gas | *Rating of Gas to be Detected | | | | | | | |
|----------------------------|-------------------------------|----|----|----|----|----|----|----|
| | 8* | 7* | 6* | 5* | 4* | 3* | 2* | 1* |
| 8* | 50 | 62 | 76 | 95 | - | - | - | - |
| 7* | 40 | 50 | 61 | 76 | - | - | - | - |
| 6* | 33 | 41 | 50 | 62 | 78 | - | - | - |
| 5* | 26 | 33 | 40 | 50 | 63 | 79 | - | - |
| 4* | - | 26 | 32 | 40 | 50 | 63 | 80 | - |
| 3* | - | - | 26 | 32 | 40 | 50 | 64 | 81 |
| 2* | - | - | - | 25 | 31 | 39 | 50 | 64 |
| 1* | - | - | - | - | 25 | 31 | 39 | 50 |

Note: These settings must only be used with a calibration gas concentration of 50% LEL.

Table 15. Calibration span setting

(3) If a sensor is to be used to detect a gas other than that for which it was calibrated and there is no intention to use an equivalent calibration gas to re-calibrate the sensor, then the required correction factor may be obtained from Table 16.

The reading shown on the gas detector controller or transmitter display should be multiplied by this number in order to obtain a more accurate gas concentration result.

| Sensor calibrated to detect | Sensor used to detect | | | | | | | | |
|-----------------------------|-----------------------|------|------|------|------|------|------|------|--|
| | 8* | 7* | 6* | 5* | 4* | 3* | 2* | 1* | |
| 8* | 1.00 | 1.24 | 1.52 | 1.89 | 2.37 | 2.98 | 3.78 | 4.83 | |
| 7* | 0.81 | 1.00 | 1.23 | 1.53 | 1.92 | 2.40 | 3.05 | 3.90 | |
| 6* | 0.66 | 0.81 | 1.00 | 1.24 | 1.56 | 1.96 | 2.49 | 3.17 | |
| 5* | 0.53 | 0.66 | 0.80 | 1.00 | 1.25 | 1.58 | 2.00 | 2.55 | |
| 4* | 0.42 | 0.52 | 0.54 | 0.80 | 1.00 | 1.26 | 1.60 | 2.03 | |
| 3* | 0.34 | 0.42 | 0.51 | 0.64 | 0.80 | 1.00 | 1.27 | 1.62 | |
| 2* | 0.26 | 0.33 | 0.40 | 0.50 | 0.63 | 0.79 | 1.00 | 1.28 | |
| 1* | 0.21 | 0.26 | 0.32 | 0.39 | 0.49 | 0.62 | 0.78 | 1.00 | |

Table 16. Correction factors

Notes:

1. *Since catalytic sensors require oxygen for correct operation, a mixture of gas in air should always be used for calibration purposes.*
2. *Assuming average performance of the sensor, the sensitivity information in Tables 14 To 16 is normally accurate to + or - 30%.*

Working Example:

If the target gas to be detected is 0-100%LEL Ethylene and the only calibration gas available to re-calibrate the sensor is Methane (at 50% LEL concentration), the procedure is as follows:

(1) Look up the star rating for each gas in Table 14:

Gas No. 14, Ethylene = 6*

Gas no. 18, Methane = 7*

(2) Then, look up the span settings for a 50% LEL calibration gas in Table 15 by selecting the row of figures next to the 7* in the "calibration gas" column. Select the figure in the 6* column of the "gas to be detected" section. The figure is 61.

(3) This means that during re-calibration, the span gas setting on the gas detector transmitter or controller should be set to 62% LEL to give an accurate measuring scale for 0-100%LEL Ethylene, when using 50% LEL Methane as the calibration gas.

Section 19.1 is used for Sensepoint XCD Catalytic Sensor only, please refer to Sensepoint Technical Manual for using Sensepoint flammable gas senso.

Please contact your local Honeywell Analytics sales or service distributor, or regional office should further clarification or additional information be required.

19.3 Meter Multiplication Factors for Sensepoint XCD-IR Propane

It is possible to apply a linear cross reference factor to the output of a sensor characterized for propane and achieve the results shown in the graph below.

Reasonable accuracy is maintained to at least the 50% LEL equivalent values of the cross-referred gasses.

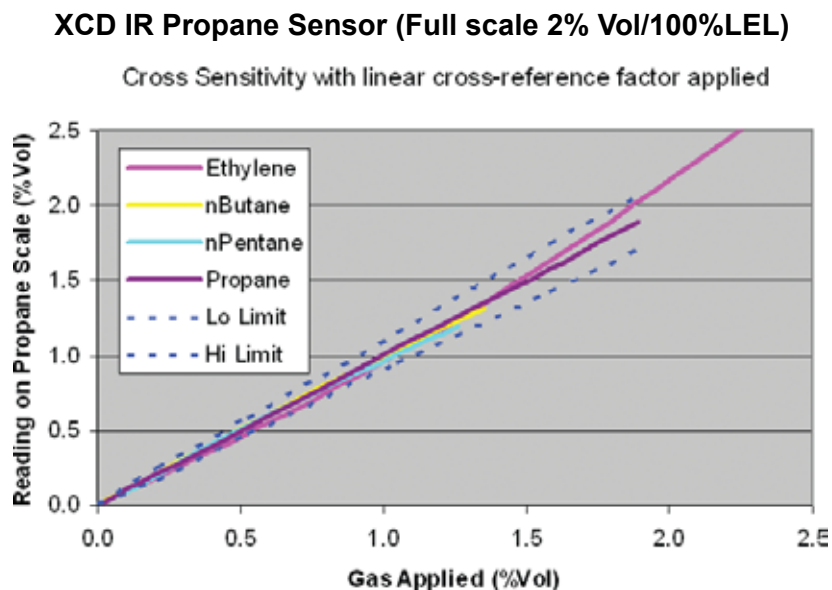

Diagram 18. Sensepoint XCD-IR (Propane) Sensor with linear cross-reference factor applied

Use the following multiplying factors to cross-refer to the propane reading:

| Gas | Multiplication Factor |
|----------|-----------------------|
| Ethylene | 3.43 |
| nButane | 0.97 |
| nPentane | 0.89 |

Table 17. Multiplying Factors

Caution: These factors only apply to gas concentrations expressed in % Volume terms. When using a linear cross reference factor the temperature compensation is based upon propane, and there may be errors at temperatures away from the calibration temperature.

NOTE

Honeywell Analytics recommends that users verify the accuracy of their instruments using test gasses wherever possible. Cross-referred measurements should be used as a guide only, not as absolute values.

XCD Transmitter

Appendix A - Modbus® Protocol A-2

A.1 Modbus and the XCD

The XCD gas detector may be fitted with the optional Modbus board. Authoritative information on the MODBUS Upgrade Kit can be found at www.modbus.org. The XCD supports Modbus/RTU over an RS-485 physical layer. The interface is isolated and includes a switchable 120 Ohm termination resistor. Baud rates 9600 or 19,200 are supported with 19,200 as the default. Most of the operations that are possible with local user interfaces can also be performed using the Modbus interface. This includes configuration operations. However, this Appendix only describes how to monitor XCD status using Modbus.

See Section 4.1.1 for information on installing the optional Modbus hardware. See Section 4.1.1 Configure Menu – Set ID Settings for information on setting the Modbus baud rate and Parity using the local user interface.

A.2 Modbus Registers

| ModBus Register Address | Information | R/W | Type | Size | Note |
|-------------------------|--------------------------------|-----|------------|------|---|
| 30001 | Main SW Version of XCD | R | u8 | 1 | |
| 30002 | EEP Version of XCD | R | u8 | 1 | |
| 30003 | WatchDog s/w Version of XCD | R | u8 | 1 | |
| 30004 | Location string | R | string[12] | 6 | |
| 30010 | ModBus slave ID | R | u8 | 1 | |
| 30011 | Monitor Status | R | u16 | 1 | Upper byte : Function Lower byte : Instrument Mode |
| 30012 | Inhibit current(mA) | R | u8 | 1 | 20 means 2.0mA |
| 30013 | Reserved | R | u16 | 1 | |
| 30014 | Active Alarm | R | u32 | 2 | bit 0 Alarm 1 is active bit 1 Alarm 2 is active |
| 30016 | Latched Alarm | R | u32 | 2 | bit 0 Alarm 1 is active bit 1 Alarm 2 is active |
| 30018 | Active Fault | R | u32 | 2 | Upper Byte: fault Lower Byte:warning Bit 0:W1~Bit 6:W6 Bit 7:F1~Bit 11:F5 |
| 30020 | Latched Fault | R | u32 | 2 | Upper Byte: fault Lower Byte:warning Bit 0:W1~Bit 6:W6 Bit 7:F1~Bit 11:F5 |
| 40001 | System ID code | R | u16 | 1 | Upper Byte : Type Code : 0x25 Lower Byte : My Address |
| 40002 | System ID code | R | u16 | 1 | Upper Byte : Type Code : 0x25 Lower Byte : My Address : Dummy Spacer |
| 40003 | Gas reading | R | f32 | 2 | |
| 40005 | Fault and Warning | R | u8 | 1 | Fault = 1100 + Number Warning = Number as is |
| 40006 | Alarm, fault and warning state | R | u8 | 1 | bit 0 Alarm 1 is active bit 1 Alarm 2 is active bit 2,3 for future expansion bit 4 Warning is active bit 5 Fault is active bit 6,7 for future expansion Note: Latching relay setting latches Modbus values in register 40006. |
| 40007 | Monitor state monitoring | R | u8 | 1 | 1 : Normal 2 : Warm Up after power on 3 : Inhibit 12 : Calibration |
| 40008 | Reserved | R | u16 | 1 | |
| 40009 | Ca libration Due | R | f32 | 2 | |
| 40011 | Measuring Unit | R | u8 | 1 | 4 : PPM 3 : %Vol 5 : %LEL 1 : mg/m3 |
| 40012 | Peak Reading | R | f32 | 2 | Peak Reading |
| 40014 | Reserved | R | u16 | 3 | |
| 40017 | Temperature (°C) | R | s16 | 1 | |
| 40018 | Reserved | R | u16 | 28 | |
| 40046 | Measuring Gas name string | R | string[14] | 7 | |
| 40053 | Reserved | R | s16 | 1 | |
| 40054 | Temperature (°F) | R | s16 | 1 | |
| 40055 | Reserved | R | u16 | 1 | |
| 40056 | Relay Status | R | u8 | 1 | 1 : Energized, 0 : De-energized |
| 40057 | Power Supply | R | f32 | 2 | |
| 40059 | Calibration Interval | R/W | u16 | 1 | |
| 40060 | Alarm Type | R/W | u8 | 1 | High nibble : Alarm 2 Type Low nibble : Alarm 1 Type 0: Disable, 1: Rising, 2:Falling |
| 40061 | Inhibit timeout | R/w | u16 | 1 | |
| 40062 | Relay configuration | R/w | u8 | 1 | Bit: 0 ~ 2: Relay Type1 ~ Relay Type3 Bit: 3~5 : Relay Sstatus1 ~ Relay Status 3 Bit: 6 : Relay Latch Status |

Note: Latching relay setting latches Modbus values in register 40006.

Find out more:

Customer business centre

Asia Pacific

Honeywell Analytics Asia Pacific Co. Ltd.
#508, Kolon Science Valley (I)
187-10 Guro-Dong,
Guro-Gu
Seoul 152-050,
Korea
Tel : +82 2 2025 0307
Fax : +82 2 2025 0329
Email: analytics.ap@honeywell.com
Website: www.honeywellanalytics.co.kr

Customer business Centre

Europe, Middle East, Africa and India

Honeywell Analytics A.G.
Wilstrasse 11-U11
CH-8610 Uster
Switzerland
Tel: +41 (0)1 943 4300
Fax: +41 (0)1 943 4398
Email: gasdetection@honeywell.com
Website: www.honeywellanalytics.com

Customer Business Centre

Americas

Honeywell Analytics Inc.
405 Barclay Blvd.
Lincolnshire, IL 60069
USA
Tel: 1-847-955-8200
Toll free: 1-800-538-0363
Fax: 1-847-955-8210
Email: detectgas@honeywell.com
Website: www.honeywellanalytics.com

Please Note:

While every effort has been made to ensure accuracy in this publication, no responsibility can be accepted for errors or omissions. Data may change, as well as legislation and you are strongly advised to obtain copies of the most recently issued regulations, standards and guidelines. This publication is not intended to form the basis of a contract.

Technical Services

AP: ha.ap.service@honeywell.com
EMEA: ha.emea.service@honeywell.com
US: ha.us.service@honeywell.com
www.honeywell.com

Issue 4 06/2010
3001M5001_4
SPXCDHMANEN
© 2010 Honeywell Analytics

Honeywell