

# Nitrogen Dioxide (NO<sub>2</sub>) Single-Point Gas Detection System



**PolyGard  
SPC3-1130**

## DESCRIPTION

Wall-mounted gas monitor with built-in nitrogen dioxide (NO<sub>2</sub>)/diesel fume gas sensor, accepts one analog remote device such as a secondary gas sensor, temperature or humidity sensor.

## APPLICATION

To detect and control levels of nitrogen dioxide (NO<sub>2</sub>) and other gases in a wide variety of commercial and industrial applications such as vehicle diesel exhaust in parking structures, engine repair shops, equipment rooms and ventilation systems, etc. The controller can communicate with any compatible electronic analog control, DDC/PLC control or automation system via binary and/or analog output signal.



NRTL Certification to STD  
**UL 61010-1**

## FEATURES

- Continuous monitoring
- One (1) built-in NO<sub>2</sub> electrochemical sensor
- Easy plug-in sensor
- One (1) remote analog input, 4-20 mA
- One (1) digital input
- Two (2) relay outputs:
  - Four stage control
  - Fail-safe assignable
- One (1) analog output, (0)4-20 mA / (0)2-10 VDC
  - Selectable for low, high, or averaging
- One (1) 24 VDC switched output
- Liquid Crystal Display (LCD)
- LED status indicators
- Accepts toxic or combustible gas, refrigerant, temperature or humidity secondary remote sensor input
- Built-in horn
- Keypad user interface
- Simple menu-driven programming
- Modular technology
- Overload & short-circuit protected
- NEMA 4X enclosure
- Easy maintenance

## SPECIFICATIONS

<b>Electric</b>				floor for standard garage applications, consult with factory for other applications
Power supply	24 VAC/VDC, -20%/+15% 50/60 Hz, reverse polarity protected			
Power consumption	5 VA (0.2 A) w/(1) remote sensor connected	<b>Type of Control</b>	General	Four-stage (S1 to S4) control, assignable up to two (2) binary/relay, horn/audible alarm, and 24 VDC / 50 mA switched outputs, i.e. low-high stage for relay output, horn / audible alarm and switched 24 VDC at any stage for remote alarming
<b>Sensor Performance</b>				One (1) 4-20 mA, for additional remote sensor, load < 55 mA / 200 Ω, reverse polarity protected
Gas detected	Nitrogen Dioxide (NO <sub>2</sub> )			Current and mean (average) value
Sensor element	Electrochemical, diffusion			Field adjustable over full range, four (4) stages (S1 to S4) per analog input, assignable to current or mean (average) value
Range	Span 0-10 or 0-20 ppm factory calibrated, 0-10 standard			
Stability & Resolution	± 0.1 ppm of reading		Analog input	
Repeatability	± 2.0 % of reading			
Long term output drift	< 2% signal loss/month		Analog reading	
Response time	t <sub>90</sub> < 60 sec.			
Sensor life expectancy	2 years, normal operating environment		Stage level / setpoint	
Sensor coverage	4,000 sq.ft., max. 7,500 sq.ft. (372 m <sup>2</sup> , max. 697 m <sup>2</sup> ), under "ideal conditions"			
<b>Installation Location</b>				
Mounting height	1 to 3 ft. (0.3 to 1.0 m) above		- hysteresis/ switching differential	Selectable for each sensor point

**SPECIFICATION**

**Type of Control (cont...)**

Digital input	One (1); can be assigned to any relay (R1, R2).
- application	Remote audio/visual alarm reset or override function
Relay outputs (R1, R2) w/status LEDs	(1) SPDT (R1), and (1) SPST-NC or SPST-NO (R2), jumper selectable
Contact rating	30 VAC/VDC, 0.5 A, max.
- each stage level (S1-S4)	Assignable to any relay
- sensor fail-safe	Assignable to any stage level
Time delay switching	Selectable for make and brake of each sensor point (SP1 to SP2) 0-9,999 seconds
Analog output	One (1), (0)4-20 mA, load < 500 Ω; (0)2-10 VDC, load > 50K Ω; jumper selectable; polarity protected, assignable to low, high or averaging of sensor inputs
VDC switched output	One (1) 24 VDC, 50 mA max
Audible alarm	83 db @ unit, enabled or disabled, selectable; assignable to stage level S1, S2, S3 or S4
Alarm acknowledgment	Menu-driven and system reset function for latched relays

**User Interface**

Keypad type	Refer to illustration "Keypad User Interface"
Touch buttons	Four (4)
Status LED's	Four (4), for system on, stage status, and failure
Digital display	Liquid Crystal Display (LCD), two lines, 16 characters per line, 1 digit resolution
- unit display	Menu selectable, per sensor; ppm, %v/v, %LEL, °F or %RH

**Environmental**

Permissible ambient	
- working temperature	14°F to 122°F (-10°C to 50°C)
- storage temperature	23°F to 86°F (-5°C to 30°C)
- humidity	15 to 95% RH, non-condensing
- working pressure	Atmospheric ± 10%

**Physical**

Enclosure (panel)	
- material	Polycarbonate, UL 94-HB, fire-retardant
- conformity	UL 50 standards
- color	Light gray
- protection	NEMA 4X (IP65)
- installation	Wall (surface) mounted, or single gang electrical box
Dimensions (H x W x D)	5.12 x 5.12 x 2.95 in. (130 x 130 x 75 mm)

Cable entry	3 holes for 1/2 in. conduit for wall (surface) mounting and 1 hole on back side of base plate for single gang electrical box mounting
Wire connection	Terminal blocks, screw type for lead wire
Wire size	Min. 24 AWG (0.25 mm <sup>2</sup> ) Max 14 AWG (2.5 mm <sup>2</sup> )
Wire distance	Max. loop resistance 450 Ω (= wire distance plus controller input resistance)
Weight	0.6 lbs (0.3 kg)

**Approvals / Listings**

- unit rating	NRTL Certification to STD ANSI/UL 61010-1 CE EMV-Compliance 2004/108/EWG Low voltage directive 73/23/EWG
- relays (R1-R2)	UL Recognized, E41515 CSA, C22.2 No. 0, No. 14 (File No. LR31928)
- enclosure	UL Listed, E208470 CSA Certified, E208470
<b>Warranty</b>	Two years material and workmanship, 12 months normal exposure for sensor element

**OPTIONS**

**Enclosure Metal, wall-mount**

- material	Galvanized steel w/zinc coating, corrosion resistant
- color	Light gray
- protection	NEMA 1, general purpose
- installation	Wall (surface) mounted, or single gang electrical box
Dimensions (H x W x D)	5.59 x 5.59 x 2.48 in. (142 x 142 x 63 mm)
Cable entry	3 holes for 1/2 in. conduit for wall (surface) mounting and 1 hole on back side of base plate for single gang electrical box mounting

**ORDERING INFORMATION**

**SPC3-1130 - 2 00 US**

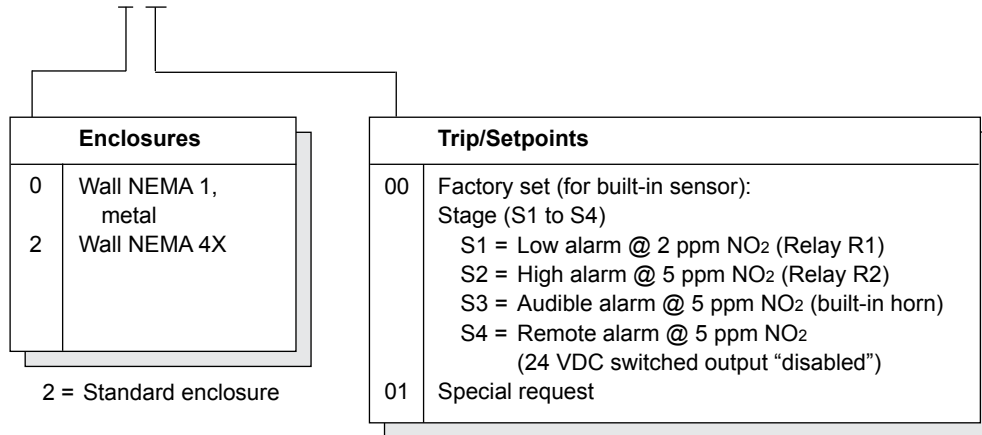

Standard control system, ordering part number:

**SPC3 - 1130 - 200 US,**

configuration includes:





Digital, programmable controller with  
 menu-driven keypad user interface,  
 LCD & LEDs, 24 VAC/VDC, 50/60 Hz  
 NEMA 4X enclosure





- Built-in: (1) NO<sub>2</sub> sensor/transmitter
- (1) Horn, audible alarm
- Input: (1) 4-20 mA, for remote sensor
- Outputs: (2) Relays, 30 VAC/VDC 0.5 A;  
 1-SPDT (R1) and  
 1-SPST-NO/NC (R2),  
 jumper selectable
- (1) Switched 24 VDC, 50 mA
- (1) (0)4-20 mA or (0)2-10 VDC,  
 selectable

**USER INTERFACE & CONTROLLER**

**Keypad User Interface**



	<b>Alarm 1</b> "Orange LED"	Flashes when any stage level setpoint is exceeded; steady when any relay output is in manual override operation
	<b>Alarm 2</b> "Red LED"	Flashes when high alarm stage 2 or multiple alarm stage level setpoints are exceeded; steady when any relay output is in manual override operation
	<b>Failure</b> "Yellow LED"	Flashes when system or sensor fails
	<b>Power</b> "Green LED"	Steady when power is ON

	Exit programming mode and saves settings; return to previous level or menu
	Enter Main Menus; scrolls through Main Menus and Sub Menus; increase or decrease a value
	Navigates through menus on the same level; moves cursor when inputting data
	Enter Sub Menus; accepts and stores data; silence horn (if assigned)

**Main Page & Main Menu**

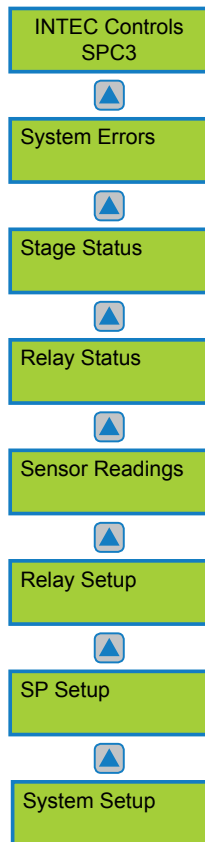

**System Operation**

All programming is made via the keypad user interface in combination with the display screen. Security is provided via two password levels. The lower level password (1234) allows to override or to reset system status functions. The upper level password (9001) allows all programming and override functions.

**Main Page Display**

After powered on, displays INTEC and part number and changes to sensor reading display unless a system error occurs; then the error is displayed.

**Main Menu**

Displays headings of "System Errors", "Stage Status", "Relay Status", "Sensor Readings", "Relay Setup", "SP (Sensor Point) Setup", and "System Setup".

**Sub Menu "System Errors"**

Displays errors, reset corrected errors, and historical error summary.

**Sub Menu "Stage Status"**

Displays status of each "SP" sensor point, stage level/setpoint exceeded.

**Sub Menu "Relay Status"**

Displays status and manual control of each output relay.

**Sub Menu "Sensor Readings"**

The current and mean/average values are displayed for each "SP" sensor point with sensing type and engineering unit (ppm, %v/v, %LEL, °F, %RH).

**Sub Menu "Relay Setup"**

Enter and/or change parameters of each relay.

- Assign de-energized or energized normal operation
- Select steady or flashing function
- Select horn function
- Select latching or non-latching mode
- Select digital input usage, and assign to any output relay
- Set delay ON/OFF time

**Sub Menu "SP Setup"**

Enter and/or change parameters of each sensor point.

- Activate sensor point
- Select sensor point type (gas, temperature, humidity)
- Select measuring range
- Select sensor signal
- Select stage/setpoint 1 to 4
- Select hysteresis
- Set delay ON/OFF time
- Select current or mean/average value
- Assign sensor point fault to stage level setpoint
- Assign setpoint 1 to 4 to any output relay
- Assign to analog output

**Sub Menu "System Setup"**

Enter and/or change system parameters.

- Select service mode
- Display software version
- Set next maintenance date
- Select service phone number
- Select averaging function, time and overlay, of any SP
- Set date, time and time format
- Change customer password
- Set failure relay
- Select power ON time
- Select analog output function

**WIRING CONFIGURATION**

**24 VAC/VDC Input Power Supply, and Analog Output "AO01"**

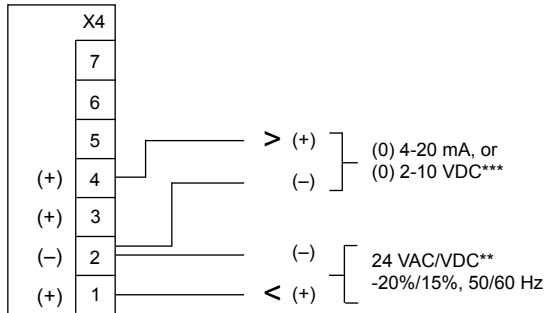

\*\*\*Jumper output signal "AO01" range selectors:

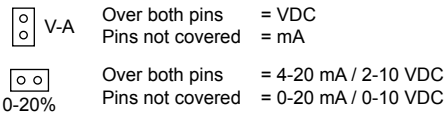

**Optional 4-20 Remote AT...V3 Series Sensor/Transmitter Input "SP02"**

4-20 mA, 3-wire sensor/transmitter

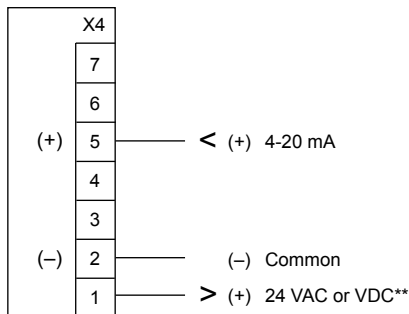

4-20 mA, 2-wire loop-powered sensor/transmitter

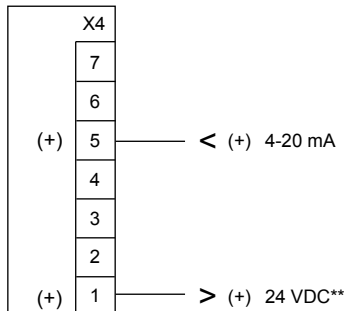

*Twisted, shielded wire is recommended for 2- or 3- wire configurations.*

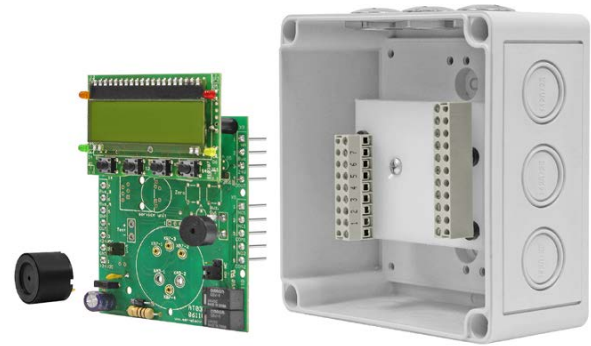

**Binary-Relay Outputs "R01 and R02", 24 VDC switched Output "S4", and Digital Input**

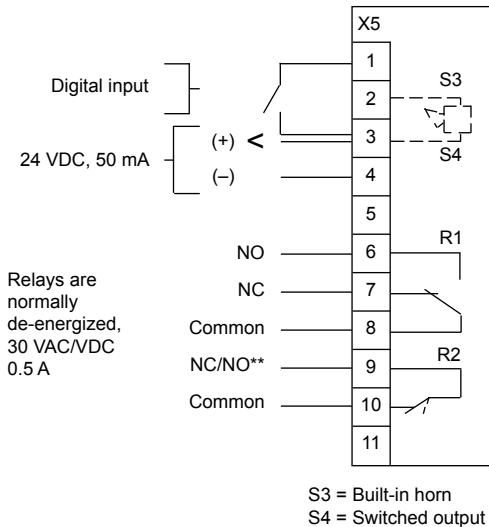

\*\*Jumper SPST relay (R2) NC/NO selector:

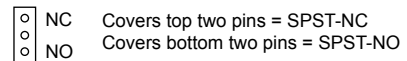

**\*\*/\*\* Attention:**

- Only the same type of power, VAC or VDC, as supplied to the unit, is available for the remote transmitter. i.e. When 24 VDC transmitter power is required, the unit must be powered with 24 VDC.
- 2-wire loop powered transmitter can use the internal power.
- 3-wire transmitters that allow power common to DC common can use the same power supply to power the SPC3 and the transmitter.
- 3-wire transmitters that require separate power common from DC common must use a separate power source.