

TIGER[®]



Instrument User Manual V3.6



Register
your instrument
online to receive
your extended
warranty.

Unrivalled Detection.

www.ionscience.com

Register your instrument online for extended warranty

Thank you for purchasing your Ion Science product.

The standard warranty of your instrument can be extended to up to five years on Tiger and two years on other Ion Science product.

To receive your extended warranty, you must register your instrument online within one month of purchase. Terms and conditions apply.

Visit www.ionscience.com/instrument-registration

Authorized Distributor:
GasDetectorsUSA.com
Houston, Texas USA
sales@GasDetectorsUSA.com
832-615-3588



Warnings

USER MANUAL:	Read and understand this user manual completely before operating the Tiger instrument.
STATIC HAZARDS:	Do not use abrasive or chemical detergents to clean the Tiger instrument as this may reduce the antistatic properties of the materials used, clean it using a damp cloth only.
MATERIAL EXPOSURE	The Tiger must not be exposed to atmospheres known to have an adverse effect on Thermoplastic polyolefin or Anti-static PC/ABS
SERVICING:	Do not remove the sensor cover in the hazardous area. No part of the Tiger may be opened in a hazardous area except for replacement of the battery pack. The Tiger must be serviced in a Non Hazardous environment and by Ion Science authorised service centres only. Do not service the instrument live; Remove battery pack before servicing Substitution of components may impair intrinsic safety.
BATTERY CHARGING:	Charge Tiger and its lithium ion battery packs in a Non Hazardous environment only.
BATTERY REPLACEMENT:	Never replace primary Alkaline battery cells while in a potentially explosive or hazardous location. Use only Duracell Procell® alkaline batteries MN1500.
BATTERY CONNECTION:	The Tiger's lithium ion and alkaline battery packs have been specially designed to allow connection to the Tiger Instrument while in potentially hazardous atmospheres. Ensure all electrical connections are clean and undamaged before connection.
BATTERY USE:	Use supplied battery packs only on the Tiger. Never replace primary alkaline battery cells while in a potentially explosive or hazardous location. Use only Duracell Procell® alkaline batteries MN1500.
FUNCTIONAL TEST:	The Tiger must be functionally checked prior to entering a hazardous area after every occasion when a connection has been made to the USB port. The instrument must complete its start-up routine and display legible readings. If the LCD display fails to show an intelligible and uncorrupted display the instrument must not enter a hazardous area.
USB CONNECTION:	The USB port can only be used in a Non Hazardous environment.

Proper Use	If the equipment is used in a manner not specified by the manufacturer, the protection provided by the equipment may be impaired.
Type of safety protection	Intrinsically safe
USB CONNECTION	The USB port can only be used in a non-hazardous environment.



Avertissement

MODE D'EMPLOI :	Veuillez lire entièrement et comprendre ce mode d'emploi avant d'utiliser l'instrument Tiger.
RISQUES LIES AUX PROPRIETES ANTISTATIQUES :	N'utilisez pas de détergents abrasifs ou chimiques pour nettoyer l'instrument Tiger, au risque de réduire les propriétés antistatiques des matériaux utilisés. Employez uniquement un chiffon humide.
EXPOSITION AUX MATERIAUX :	N'exposez pas le Tiger à des atmosphères connues pour avoir un effet indésirable sur la polyoléfine thermoplastique ou le PC/l'ABS antistatique.
ENTRETIEN :	Ne retirez pas le couvercle du capteur dans les zones dangereuses. N'ouvrez aucune partie du Tiger dans une zone dangereuse, sauf pour le remplacement de la batterie. L'entretien du Tiger doit se dérouler dans un environnement non dangereux et être confié uniquement à des centres de service agréés Ion Science. Ne procédez pas à l'entretien de l'instrument lorsqu'il est sous tension. Otez la batterie avant l'entretien. Le remplacement de composants risque de nuire à la sécurité intrinsèque.
CHARGE DE LA BATTERIE :	Chargez le Tiger et sa batterie lithium-ion uniquement dans un environnement non dangereux.
REPLACEMENT DES PILES:	Ne remplacez jamais de piles alcalines dans un endroit dangereux ou potentiellement explosif. N'utilisez que des piles alcalines Duracell Procell MN1500.
CONNEXION DES PILES/DE LA BATTERIE :	Les batteries lithium-ion et les piles alcalines du Tiger ont été spécialement conçues pour permettre la connexion à l'instrument Tiger dans des atmosphères potentiellement dangereuses. Assurez-vous que les connexions électriques sont propres et intactes avant la connexion. L'indice de protection des instruments Tiger étant ramené à IP 20 lors du retrait de la batterie, évitez de remplacer les batteries dans des environnements poussiéreux ou humides.
UTILISATION DES PILES/DE LA BATTERIE :	N'utilisez que les batteries fournies avec le Tiger. Ne remplacez jamais des piles alcalines primaires dans un endroit dangereux ou potentiellement explosif. N'utilisez que des piles alcalines Duracell Procell MN1500.
ESSAI DE FONCTIONNEMENT :	Le Tiger doit subir un essai de fonctionnement avant de pénétrer dans une zone dangereuse chaque fois qu'une connexion a été effectuée au port USB. L'instrument doit terminer sa routine de démarrage et afficher des valeurs lisibles. Si l'écran LCD n'affiche pas de données correctes et intelligibles, n'utilisez pas l'instrument dans une zone dangereuse.
CONNEXION USB :	Le port USB peut uniquement être utilisé dans un environnement non dangereux.

Utilisation appropriée	Si l'équipement est utilisé d'une manière non spécifiée par le fabricant, la protection fournie par l'équipement peut être altérée.
Type de protection de sûreté :	Sécurité intrinsèque
CONNEXION USB :	Le port USB peut uniquement être utilisé dans un environnement non dangereux



Declaration of conformity

Manufacturer: Ion Science Ltd, The Way, Fowlmere, Cambridge, UK. SG8 7UJ

Product: TIGER

Product description: Intrinsically safe photo-ionisation gas detector for detecting volatile organic compounds

Directive 2014/34/EU Required Coding -  II 1 G Ex ia IIC T4 Ga

$T_{amb.} = -15^{\circ}\text{C}$ to $+45^{\circ}\text{C}$ (with Lithium ion Battery pack)

$T_{amb.} = -15^{\circ}\text{C}$ to $+40^{\circ}\text{C}$ (with Alkaline Battery pack)

Certificate Number- ITS09ATEX26890X issue 2
IECEX ITS 10.0036X issue 4

Notified body: Intertek, 0359, Chester, UK

Report number: 102394781CHE-001

Intertek 3193491 Conforms to UL Std. 913, 61010-1 & Certified to CAN/CSA Std. C22.2 No.61010-1

Standards

BS EN 60079-0: 2012 Electrical apparatus for explosive gas atmospheres. General requirements

BS EN 60079-11: 2012 Explosive atmospheres. Equipment protection by intrinsic safety "i"

BS EN61326-1:2006 Electrical equipment for measurement, control and laboratory use - EMC requirements. Group 1, Class B equipment - (emissions section only)

BS EN61326-1:2006 Electrical equipment for measurement, control and laboratory use - EMC requirements. Industrial location immunity - (immunity section only)

BS EN50270:2006 Electromagnetic compatibility - Electrical apparatus for the detection and measurement of combustible gases, toxic gases or oxygen. Immunity Type 2 - industrial environments.

CFR 47:2008 Class A Code of Federal Regulations: 15 Subpart B- Radio Frequency Devices - Unintentional Radiators

Other Standards

BS EN ISO 9001: 2008 Quality Management System - Requirements

BS EN 80079-34: 2011 Application of Quality Systems for equipment manufacture

On behalf of Ion Science Ltd, I declare that, on the date this product accompanied by this declaration is placed on the market, the product conforms to all technical and regulatory requirements of the above listed directives.

Name: Mark Stockdale

Position: Technical Director

Signature:

Date: 28th April 2016





Contents

Warnings	3
Avertissement	4
Declaration of conformity	5
Statements	8
Responsibility for Use	8
IMPORTANT.....	8
Quality Assurance.....	8
Disposal.....	8
Calibration Facility	8
Legal Notice.....	8
Introduction to Tiger	9
Getting started	10
The Manual.....	10
Inlet Nozzles	10
Turn On.....	10
Turn Off.....	10
Batteries.....	10
Select the Gas	10
Set Alarm Levels.....	10
Understanding the keypad	11
General Description	11
Keypad Function Descriptions	11
Understanding the display screen	12
Screen Display.....	12
Status icon	12
Main Screen Area	13
Soft key areas.....	14
Using your Tiger	15
Tiger PC software	19
PC Requirements	19
Installation of TIGER PC Software	19
Connecting TIGER to a PC.....	21
The Features Screen	23
The Configuration Screen.....	24
The Gas Table Screen (including setting alarm levels)	28
The Firmware Screen	29
Downloading Data Logged Readings	31
The Health Safety Screen.....	32
The Snapshots Screen	32
Software Disclaimers	33
Batteries	34
Recharging Batteries	34
Replacement / Exchange of Battery Packs	35
Replacement of Non-rechargeable Batteries in Battery Pack	36
Diagnostics	37
Maintenance	38
Calibration.....	38
Inlet Nozzle (Part number: 861443).....	39
Inlet Nozzle (Part number: 880207).....	39
PTFE Filter Disc (861221)	39
PID Sensor/Lamp Replacement and Cleaning	40
Lamp Cleaning.....	41
Tiger parts	42
Tiger main assembly.....	42
Front end filter assembly	42
Accessories	43
Instrument warranty and service	44
Warranty	44
Service.....	44
Contact Details:	44
Technical specification	45



Manual log.....46



Statements

Responsibility for Use

TIGER instruments detect a large range of gases which are potentially dangerous from both a poisoning and/or an explosive perspective. TIGER instruments have many adjustable and selectable features allowing the detector to be used in a variety of ways. Ion Science Ltd can accept no responsibility for the incorrect adjustment of features that cause harm or damage to persons or property. TIGER can be used as a personal safety device. It is the user's responsibility to respond appropriately to an alarm situation.

Inadequate performance of the gas detection equipment described in this manual may not necessarily be self-evident and consequently equipment must be regularly inspected and maintained. Ion Science Ltd recommends that personnel responsible for equipment use a regime of regular checks prior to use to ensure it performs within calibration limits, and that a record be maintained which logs calibration check data. The equipment should be used in accordance with this manual, and in compliance with local safety standards.

IMPORTANT

It is essential that the TIGER is always used with a supplied 0.5 micron PTFE Filter Disc fitted to the front of the instrument. Without a filter, particles of debris and dust can be drawn into the detector inhibiting the function of the instrument. These filters are consumable and should be changed after every 100 hours of use. The frequency of replacement should be increased for dusty or moisture laden environments. Filters are available from your distributor or at www.ionscience.com.

Quality Assurance

TIGER has been manufactured in compliance with ISO9001:2008, which ensures that the equipment supplied to our customers has been designed and assembled reproducibly, from traceable components, and leaves Ion Science Ltd calibrated to stated standards.

Disposal

Dispose of TIGER, its components and any used batteries in accordance with all local and national safety and environmental requirements. This includes the European WEEE (Waste Electrical and Electronic Equipment) directive. Ion Science Ltd offers a take back service. Please contact us for more information. The TIGER field case material is recyclable polypropylene.

Calibration Facility

Ion Science Ltd offers a calibration service including the issue of certification confirming calibration with equipment traceable to national standards. A TIGER calibration kit is available from your distributor or service centre or at www.ionscience.com. Ion Science Ltd recommends annual return of all instruments for yearly service and calibration.

Legal Notice

Whilst every attempt is made to ensure the accuracy of the information contained in this manual, Ion Science Ltd accepts no liability for errors or omissions, or any consequences deriving from the use of information contained herein. It is provided "as is" and without any representation, term, condition or warranty of any kind, either express or implied. To the extent permitted by law, Ion Science Ltd shall not be liable to any person or entity for any loss or damage which may arise from the use of this manual. We reserve the right at any time and without any notice to remove, amend or vary any of the content which appears herein.



Introduction to Tiger

TIGER is a portable gas detector that uses Photo-ionization technology to detect a large range of Volatile Organic Compounds (VOC's) which can be dangerous from both a poisoning and explosive perspective.

The TIGER uses a Photo-Ionization Detector (PID) to measure gas concentrations. The patented fence electrode technology minimises the effects of moisture and contamination, avoiding the need for compensation.

Survey is the default mode of operation. This mode is often used in applications such as Head Space Sampling and Leak Detection where several areas (or Zones) are to be monitored and readings data logged. All sensor readings are real time measurements and alarm levels are set manually.

Health and Safety (optional) mode is used to check for conformity of short-term exposure levels (STEL) or time-weighted averages (TWA) that are specific for particular hazardous environments (for example EH40 in the UK and OSHA in the USA). In this mode of operation STEL's and TWA's are continually calculated and compared to levels set in the instrument's gas table.

The TIGER can be upgraded from the users own desk top. Additional features can be added without the need to return the instrument to a service centre.

Like its predecessor, PhoCheck+, the TIGER also has an intuitive graphical interface allowing easy access to instrument settings. Two soft keys A and B can be configured to suit the user's application, so many functions can be selected without entering the main menu structure. This improves efficiency of use, particularly with repeatable tasks.

TIGER PC (the TIGER's PC Software) maintains the intuitive look and feel by adopting the same graphical symbols. TIGER PC also helps manage logged data files and multiple instrument settings in a clear and concise way.

The TIGER uses a Lithium-ion battery pack that not only boasts an impressive running time and short charge time, but also allows the battery pack to be replaced in potentially hazardous environments. Field replaceable alkaline battery packs (non-rechargeable) are also available for when power to recharge is unavailable.

The TIGER has true USB capability so the instrument can be connected directly to a PC via a standard USB cable. It also offers fast data download.

A loud audio output, vibration and bright LED's indicate alarm conditions. Orange and Red LED's indicate High and Low conditions respectively. This colour scheme is used within TIGER PC to offer clear indication of alarm levels within logged data.



Getting started

Thank you for choosing TIGER from Ion Science Ltd. We hope that your TIGER will give you many years of active and trouble-free service.

The Manual

Ion Science Ltd recommend that you familiarise yourself with this manual before using your TIGER. The 'Statements' and 'Introduction to TIGER' sections contain important information, which should be read before you turn your TIGER on for the first time.

Inlet Nozzles

Ensure that the inlet nozzle supplied is fitted to your TIGER. Details on how to fit and change inlet nozzles is detailed in the 'Maintenance' section. If the supplied inlet nozzle is unsuitable for your application, details of alternative inlet nozzles can be found in the 'Maintenance' section as well.

Turn On

Press the **Enter / On/Off** key once to turn TIGER on.



Turn Off

Press and hold the **Enter / On/Off** key for 3 seconds, indicated by a 3 second countdown, to turn TIGER off. (**Note:** If the TIGER fails to shut down, press the **Escape (Esc)** key once or twice to return to the main screen, then press and hold the **Enter / On/Off** key again.)



Batteries

Check that your TIGER has sufficient charge for use. The battery icon (see 'Understanding the display screen') should show at least two full segments.

Rechargeable Batteries

TIGER instruments leave the factory with the Rechargeable Battery Pack (A2) fully charged. However prolonged periods of storage may result in the battery pack discharging. We recommend charging the instrument for seven hours before use. See the 'Batteries' section of this manual pages 33 to 35.

Alkaline Batteries

An alkaline AA battery pack (A3) is also supplied with the TIGER. For more information please see the 'Batteries' section of this manual.

Select the Gas

TIGER instruments leave Ion Science Ltd pre-set for gas type TVOC (total volatile organic compounds). Instruments are factory calibrated against isobutylene and all response factors are equivalent to this. By changing the gas from the internal gas table all readings will be given using that gas's response factor. Switch the TIGER on by pressing the Enter / On/Off key once.

Press the **Information** icon  (see 'Using your TIGER') and check the correct gas alarms are selected. Change the gas (if necessary) as instructed under Gas Selection in the 'Using your TIGER' section.

Set Alarm Levels

We recommend that alarm levels are set to user specifications as soon as possible before the TIGER is used for the first time. Please see the 'Using your TIGER' section of the manual for details of how to set alarm levels.

TIGER PC. The full functionality of your TIGER can only be realised through the TIGER PC software. Ion Science Ltd recommend that you load the software supplied with your instrument and set up your TIGER according to the instructions in the 'TIGER PC Software' section of this manual.



Understanding the keypad

General Description

The keypad comprises two soft keys: **A** and **B**, **Up** and **Down** arrow keys, an **Escape (Esc)** key, and an **Enter / On/Off** button. In general, setup and application settings are selected and adjusted via the soft keys, options are selected by the arrow keys and confirmed by the **Enter** key. A single press is used as a switching operation. A continuous press is used to adjust numbers or change gas selections by automatically rolling.

Keypad Function Descriptions



Soft keys **A** and **B** rely on graphical prompts on the display to indicate their functionality.



Note: Pressing both soft keys together switches the flashlight / torch on and off.



Up and **Down** keys are used to adjust settings and navigate through the menu structure.



Enter / On/Off key is used to accept adjustments and select functions; also to turn the TIGER on and off.



Escape (Esc) key is used to abort an adjustment or exit from a menu.

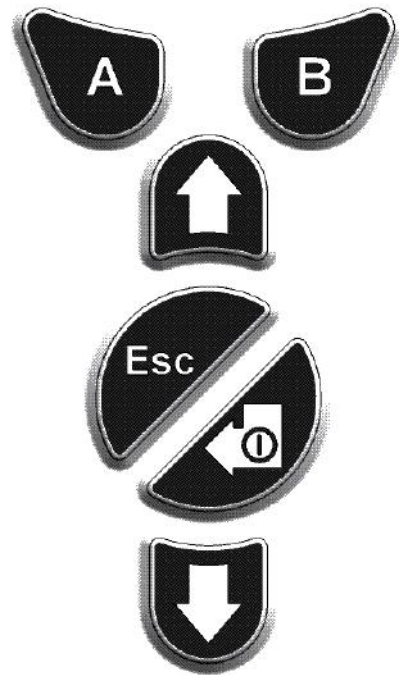



Understanding the display screen

Screen Display

The display is divided into four sections.

Fixed LCD Status icons fill the top of the screen offering instrument status at a glance. The Icons display only when a function is selected. The main central viewing screen will display readings in large numbers only, 4 digits and decimal place will display 0.001 ppm to 19,999 ppm. Two soft key areas have been set aside as soft key indicators. The area between the soft key indicators displays the measurement units.



Left is the default display with no functions active.



Right is the display with all functions active.

Status icon



Health and Safety (optional): The icon consists of a single part and will flash in an alarm condition and when health and safety readings are being collected.



Peak Hold: When peak hold is switched on, the icon appears.

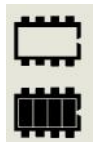

Memory Status: This icon only appears if the instrument has the data logging functionality. Four sections within the border fill as the data log memory is filled. Empty border = 100% memory available through to full, where all segments are present.



USB: The icon will appear when connected to a host device.

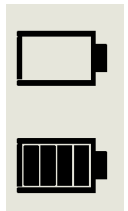

Battery Status: This icon consists of a border and four segments. The segments fill or empty to available capacity. When discharging, the border of the final segment will flash for one minute before the instrument shuts down. When charging, the segments will successively fill until all four segments are highlighted, indicating full charging.



Understanding the display screen



Backlight: Light beam lines appear when the backlight is on.



Sound: The main body of the icon is present at all times. The disable lines appear if all 3 alarm sounders are disabled and the volume is at 0%. Three sound projection lines indicate the volume level. However there are four sound levels and the quietest level has no line.



Alarm Bell: The icon consists of 2 parts, the Bell and the sound bars. When the instrument reaches a 'Low alarm' the Bell and one sound bar will flash; when a 'High alarm' is reached the Bell and both sound bars flash.



Flashlight / Torch: When the flashlight / torch is illuminated the light beams appear.



Lock: The Lock icon will appear when the configuration of the TIGER has been locked in TIGER PC. Soft keys in Button **A** column are enabled and Buttons in column **B** disabled, see page 13.

Main Screen Area

During normal operation this area displays the readings in four large numbers, with the units of measurement below.

During setup and adjustment, a function bar overlays the main screen.



Understanding display screen

Soft key areas

The following icons will appear in the soft key areas as soft key options. They are selected using the **Up** and **Down** keys. Those labelled 'optional' will only appear if your TIGER has that functionality. These icons can be reorganised using the TIGER PC software.

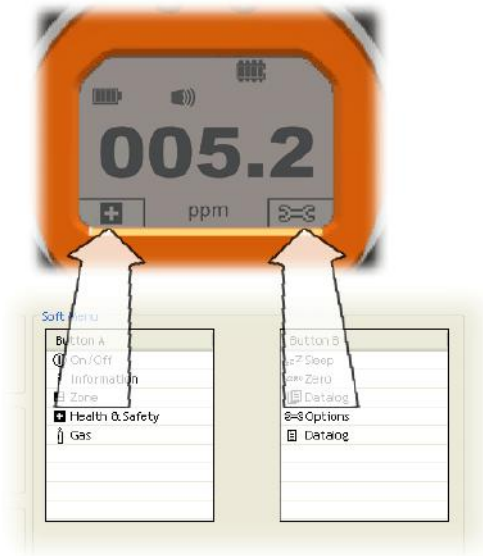

Button A

	Information
	Zone(s)
	Gas Selection
	Options
	Health and Safety (optional)
	Multiple Data Log (optional)

Button B

	Sleep
	Zeroing
	Peak Hold
	Average
	Data Log (optional)
	Stealth



Using your Tiger

Instrument functionality is broken into two parts; Application and Setup. Application settings are initially selected via the soft keys **A** and **B**. Setup functions like Backlight, Sound, Calibration and Alarm setting are adjusted within **Options**. Many of the screens have a 2 second time out which returns to the main screen if no other keys are pressed.

On

To switch the TIGER on press the **Enter / On/Off** key once. Startup screen 1 appears showing the TIGER logo. Startup screen 2 contains variable text sent from the TIGER PC configuration screen. The lower half of the screen contains the instrument IRN (Internal Reference Number) and firmware version. The third screen shows TIGER checking that the lamp has 'struck'. When 'OK' appears, the working screen will follow. If the lamp fails to strike, turn the TIGER off, wait for 30 seconds and try again. If the problem persists, change the lamp or contact Ion Science Ltd or your distributor.

Off

To switch the TIGER off press and hold the **Enter/ On/Off** key. A three second count down takes place before the instrument shuts down. During this count down the instrument activates the upper alarm, viz., red LED's flash and audible alarm sounds. This is done to alert the user to avoid accidental switch off.

Sleep

Press and hold the **Zzz** soft key to send the TIGER to sleep. A three second count down takes place before entering sleep mode. This function is not available when the instrument is locked. All peripherals switch off. Only Zzz remains on the screen. Press the **Esc** key to awaken the instrument. (The instrument can also enter 'Sleep mode' during data logging when the duration between logs exceeds two minutes. This is a power saving function which only occurs when a tick box is set in TIGER PC.)

Zeroing

Pressing the **Zero** soft key presents two zero options  selected with the **Up** or **Down** keys. The upper symbol represents an absolute zero. The lower symbol represents a relative zero which follows the drift of the PID detector. Having made your selection, press **Esc**. If the relative zero has been selected TIGER will zero itself before returning to the main screen.

Zones

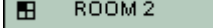
Press the **Zone** soft key to display the currently selected Zone:  The TIGER's default is 'Zone 1' Zones are set up in TIGER PC only and the name given to the zone(s) will appear on the screen. Use the **Up** and **Down** keys to select alternative zones.

Single Data Log (optional)

Press the **Single Data Log** soft key to take a single data log reading. The single data log symbol appears with a tick:  Press **Esc** to return to the main screen. Press the **Single Data Log** soft key again to take another reading. The fixed LCD memory icon flashes off when a single log is taken.

Multiple Data Log (optional)



Pressing the **Multiple Data Log** soft key results in the multiple log symbol appearing with a question mark:

 Press the **Enter** key to start the data logging process based on TIGER PC setup. A tick appears beside the question mark, confirming that data logging has started. The fixed LCD memory icon flashes at 1 Hz while continuous data logging is in progress. Press **Esc** to return to the main screen. To stop data logging, press the soft key again. A crossed out data log symbol is presented with a question mark. Press the **Enter** key to confirm the action. A tick appears beside the question mark, confirming that data logging has stopped and the LCD memory icon ceases to flash. Press **Esc** to return to the main screen.



Using your Tiger

Health and Safety (optional)



Press the **Health and Safety** (H&S) soft key to display the H&S symbol with a question mark to ask if the user wishes to proceed:  Press **Enter** to start the calculation. The STEL (Short Term Exposure Level) and TWA (Time Weighted Average) values are shown. The fixed LCD H&S icon will continually flash while calculating. Pressing the **Enter** key while the values are displayed presents the user with a screen asking if the calculation should stop. Press **Enter** again to stop the calculation. Press **Esc** to return to the main screen. If a gas has no STEL and TWA level allocated in the gas table the following symbol will appear: .

IMPORTANT: TIGER STEL.

While the TIGER calculates the 15 minute STEL the instrument displays the ongoing STEL as it is calculated. This ongoing calculation is for indication purposes only to allow the user to gauge how the calculation is progressing. Only the final reading at the end of the calculation is logged by the instrument and should be referenced by the user.

Gas Selection

Press the **Gas Selection** soft key to display an alphabetical letter which can be changed using the **Up** and

Down keys:  Press the **Enter** key to present the gases beginning with that letter. Using the **Up** and **Down** keys scroll through the gases starting with that letter to find the subject gas. Press **Enter** to select the chosen gas. If a tick appears, press **Enter** again and TIGER will use the relevant data for the chosen gas from the gas table for alarms and response factor etc. Should the selected gas have no numeric response factor then a warning screen  will appear. The message can be cleared by pressing the **Enter** key and the gas will still be selected. An alternative lamp type may then be selected to match the chosen gas. Should an incompatible gas/lamp combination be selected the instrument will show the warning screen again.

Peak Hold

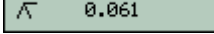
Press the **Peak Hold** soft key to present the screen  When Peak Hold is selected the sub display will appear and this will continue to display the peak reading until peak hold is no longer required. To deselect the peak hold function press **Esc**

Average

Press the **Average** soft key to display a rolling average over 10 seconds. A tick appears when time is up. Pressing the **Average** soft key again resets the calculation even if there is an average already running. Press **Esc** to return to the main screen.

Stealth

When selected all audible and visual alarms are disabled except for the alarm indicator on the screen. This function may help avoid triggering panic in public places.

Options

Press the **Options** soft key to give access to various adjustable features, selected with the **Up** and **Down** keys. Press **Enter** to confirm selection.



Backlight

Four options are presented: 'Permanently Off', 'Permanently On', 'On in low ambient light' and 'Timed' (Set the time in TIGER PC). Select the preferred option with the **Up** and **Down** keys and confirm with **Enter**.



Using your Tiger



Sound

The sound options are presented as set up in TIGER PC. Use the **Down** key to select either keypad beep, alarm sound, crescendo or percentage volume. Press **Enter** to turn selection on or off. For percentage volume, press **Enter** again to confirm selection. The frame will flash. Use **Up** and **Down** keys to change the percentage volume and press **Enter** to confirm the chosen value. Press **Esc** twice to return to the main screen.



Calibration

Only two options are presented: Factory Calibration and Custom Calibration. Select the preferred option with the **Up** and **Down** keys and confirm with **Enter**. Whichever calibration standard is selected, the TIGER will operate against that calibration. Readings taken against unsatisfactory calibrations may be unreliable.



Factory Calibration

Not for operator use.

Return to Ion Science Ltd or your distributor for calibration. (see the 'Maintenance' section of the manual page 37)





Custom Calibration

see the 'Maintenance' section of the manual page 37.



Alarms

Upper  and Lower  alarm settings are displayed. Select the subject alarm using the **Up** and **Down** keys and press **Enter**. The arrow(s) on the chosen alarm will flash. Adjust the level using the **Up** and **Down** keys and press **Enter**. Repeat, if necessary for the other alarm. Press **Esc** twice to return to the main screen.

Note: The Lower alarm setting must never be greater than the Higher alarm.



Units

Select the available units by using the **Up** and **Down** keys and then press **Enter**.



Lamp

Select the lamp type by pressing the **Up** and **Down** keys and then press **Enter**



Information

Pressing the **Information** soft key allows access to a number of other information screens. Use the **Down** key to scroll through the screens. Press **Esc** to return to the main screen:



Using your Tiger

First Screen	Gas selected	
	Response Factor	RF
	Upper alarm	
	Lower alarm	
Second screen	Lamp selected	
	Date of Factory calibration	
	Date of Custom calibration	
	Date of Select tube calibration (optional)	
Third Screen	SPAN 1	SPAN 1 (gas concentration set in TIGER PC)
	SPAN 2	SPAN 2 (gas concentration set in TIGER PC)
	PID detector in units	PID
	PID sensor A/D reading	A/D
Fourth Screen	Sort Term Exposure Levels (optional)	STEL
	Time Weighted Average (Optional)	TWA
	Internal Reference Number	IRN:
	Firmware version	Firmware:
	Bootloader version	Bootloader:
	Battery type and voltage	
Fifth Screen	Memory available	
	Gas Table Date	
	Date and time	
Sixth Screen	Features. A icon will appear for each feature available	Features



Tiger PC software

PC Requirements

TIGER PC Software must be used in conjunction with a PC or laptop using Windows XP, Windows Vista or Windows 7. The software is supplied on a USB memory stick.

Installation of TIGER PC Software

When the memory stick is plugged into a USB socket the following screen (below left) should appear. If it doesn't, view the content of the memory stick and double click the file named:

' ion_cd_Tiger.exe '.

On the 'TigerPC' screen (below), select 'Install TigerPC' and click OK

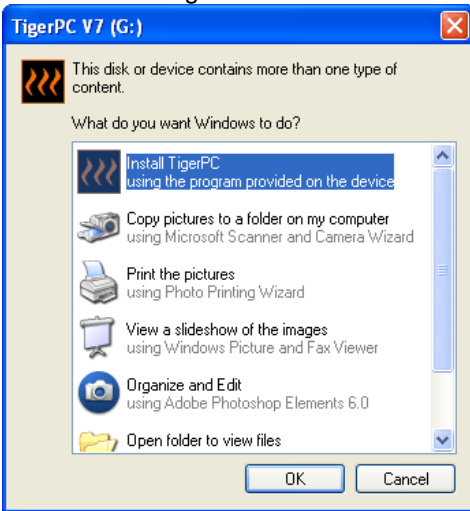

On the 'Ion Science' screen (below), select 'Install Tiger Software'



On the 'Welcome' screen (below), click 'Next' to proceed.

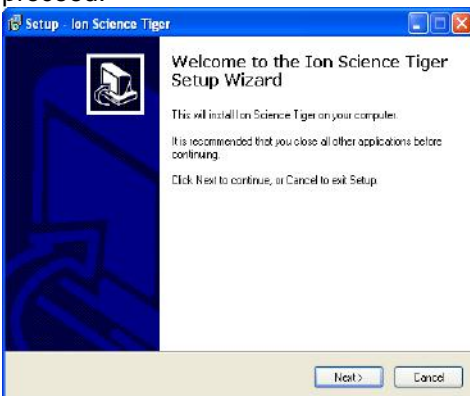

On the 'Select Destination Location' screen (below), click 'Next' to create an 'Ion Science' folder on your C drive.

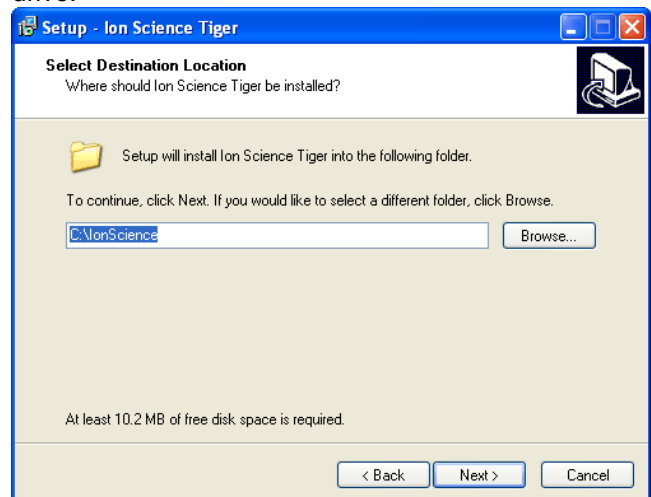



Tiger PC software

On the 'Setup' screen (below) click 'Next' to create an 'Ion Science' start up folder.

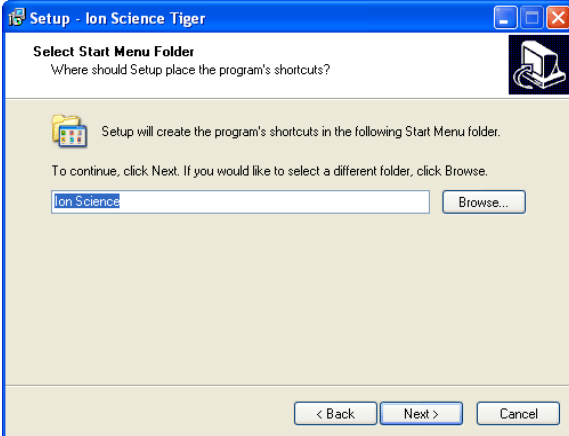

On the 'Select Additional Tasks' screen (below) tick the box and click 'Next' to Create a desktop icon

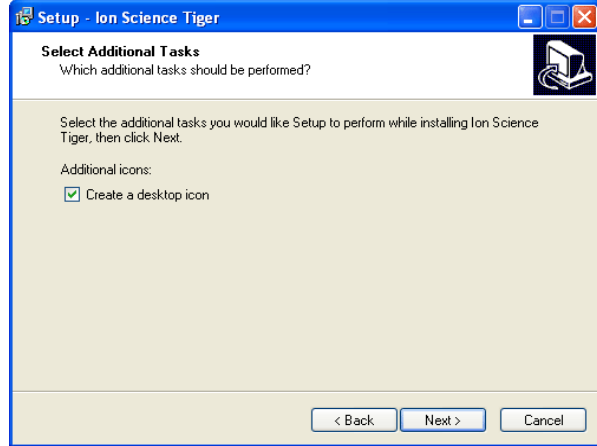

On the 'Ready to Install' screen (below), click 'Install'

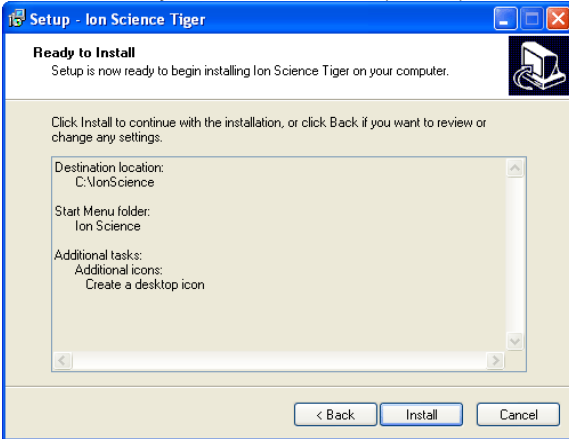

On the 'Installing' screen (below) Click 'OK'.

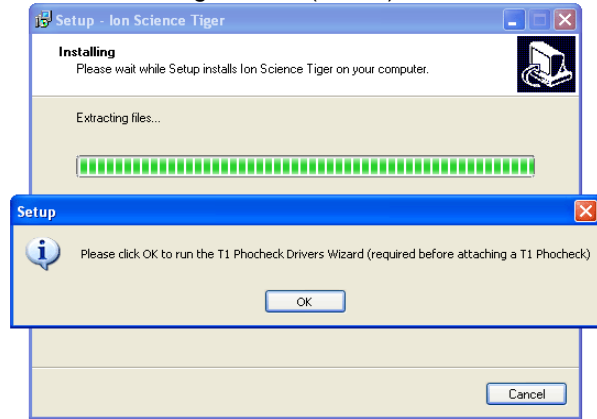

Click 'Next' on the 'Device Driver' screen,



'Finish' on the 'Installation Wizard'



and 'Finish' on the 'Setup Wizard'.





Tiger PC software

Connecting TIGER to a PC

1. Double click the TIGER icon on your desktop and open TIGER PC.
The Home page should appear:



The Help Screen

This screen will show you if a new version of PC software is available. You can then install the upgrade if required.

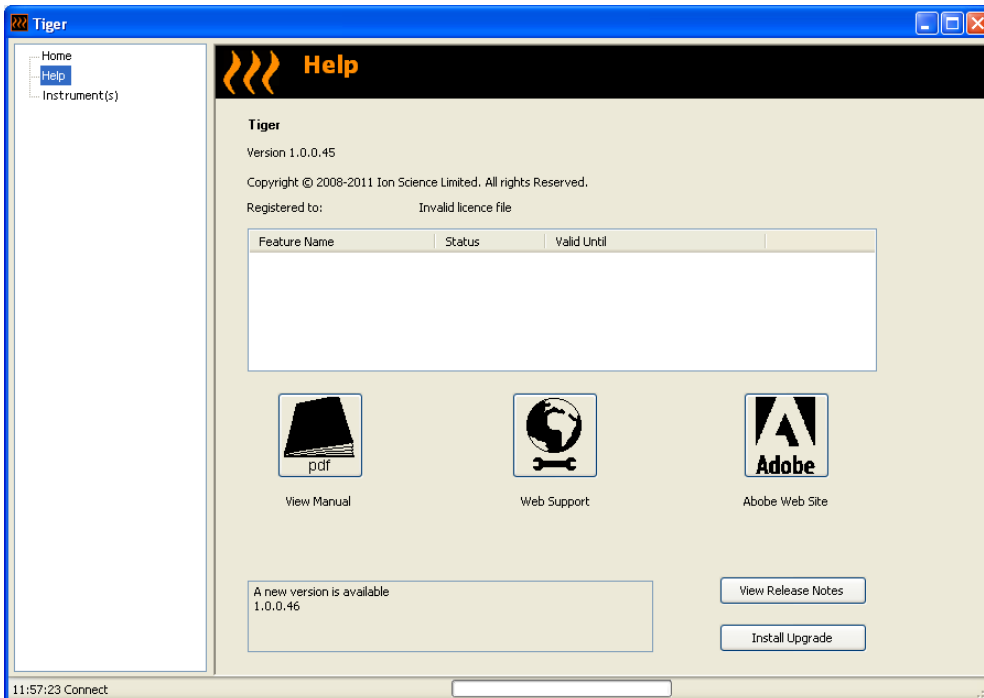



Tiger PC software

- Click on 'Instrument(s)'. If your TIGER has previously been connected to your PC your instruments IRN (Internal Reference Number) will appear.

Note: If, while using this software your TIGER should inadvertently be turned off or disconnected from your computer, click on 'Instrument(s)' again and proceed as below:

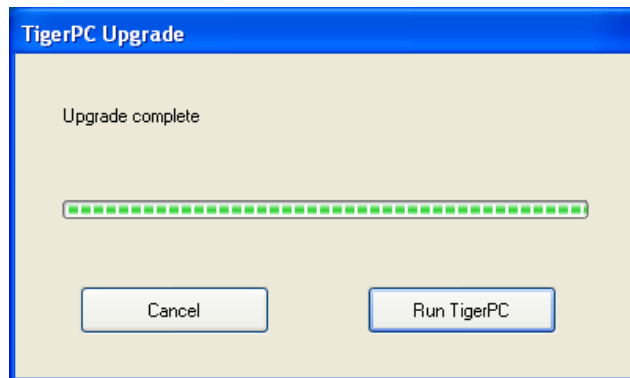
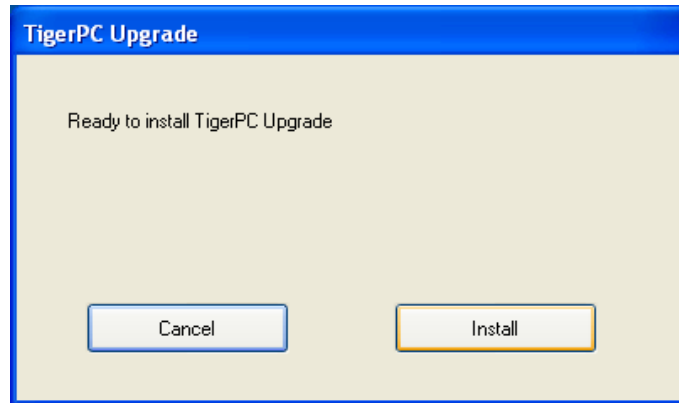

- Switch TIGER on and when fully booted up connect to a USB socket on your PC using the USB cable supplied. If the 'Found New Hardware' screen appears, follow the prompts to install your instrument on your PC.
- Click on 'Read'. Your instrument number will appear under 'instrument(s)' (if it was not there already) and the Instrument Summary page will appear.

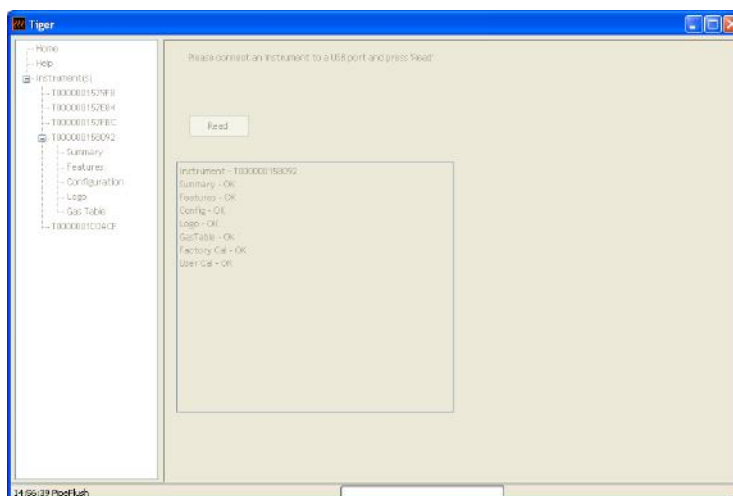



Tiger PC software

- This page gives the current status of your TIGER. If the 'snapshot' screen appears click 'Yes'. You can delete the snapshot later if you wish (see 'TIGER PC Software').

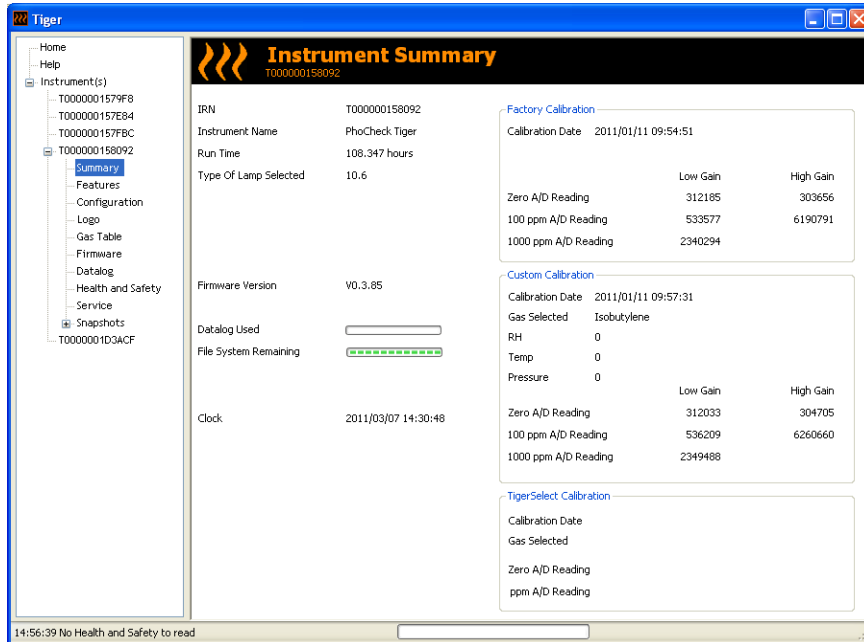
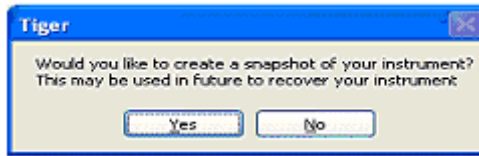

The Features Screen

The 'Features' screen indicates which of the available updates has been added to your TIGER. Should you wish to purchase additional features, contact Ion Science Ltd or your Distributor. Some updates may be available on the website www.ionscience.com. Once the transaction is complete and confirmed, click on Update to add the relevant features to your TIGER.

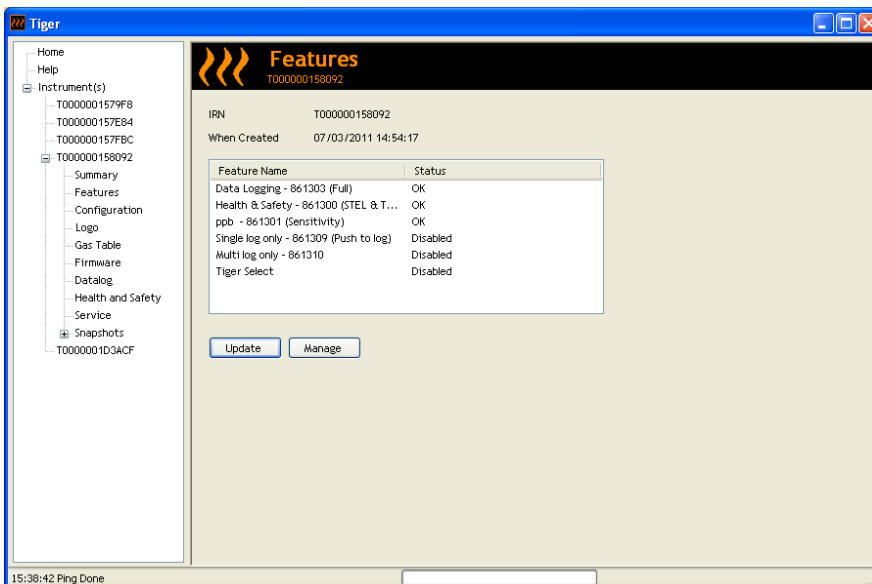



Tiger PC software

The Configuration Screen

Use this screen to configure your TIGER.

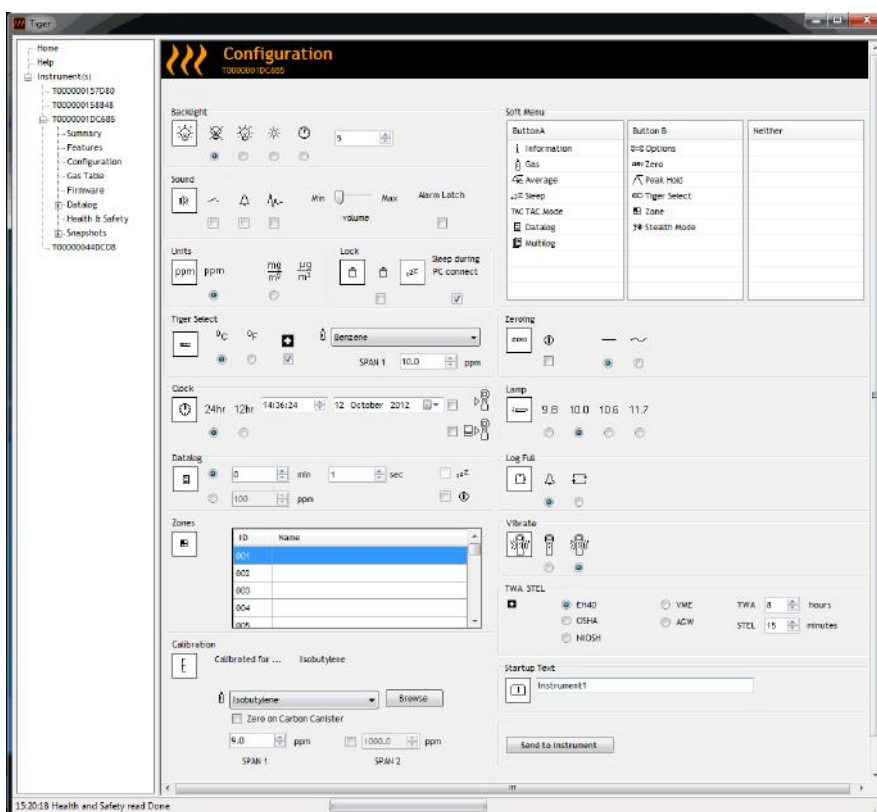

Backlight

Choose from 'Permanently Off', 'Permanently On', 'On in low ambient Light', or 'On For Limited Time'. The Backlight Timeout can be set from 1 to 99 seconds.

Sound

The three icons represent: key press; alarm; and crescendo. Crescendo increases the sound as the upper alarm is approached. Sound on each of these may be enabled or disabled by ticking or un-ticking the box. Sound volume is adjusted with the slider.

Units

The units of measurement may be chosen as parts per million (ppm) or milligrams per cubic meter cubed (mg/m^3). If you have the high the high sensitivity option / upgrade then Parts Per Billion (ppb) and Micrograms per meter cubed ($\mu\text{g}/\text{m}^3$) are also available.

Lock

The TIGER may be locked in any configuration to avoid unauthorised changes by the operator. A tick in the box locks the instrument. Soft keys in Button **A** column are enabled and Buttons in column **B** disabled. Sleep during PC connect will send the instrument into sleep mode while it is connected to the PC software. The instrument will awaken as soon as it is disconnected from the PC software.

Soft Menu

The various functions may be allocated to the soft buttons in any order of preference by dragging and dropping the icons.



Tiger PC software

Tiger Select

Please refer to the TIGER Select User Manual.

Zeroing

This function allows either an assumed constant zero or for the zero to be tracked compensating for the shift in the zero of the PID lamp during operation. The function may be enabled or disabled by ticking or un-ticking the box. Constant or tracked zero is selected by use of the radio buttons associated with the icons.

There are various options for zeroing a TIGER or TIGER Select. The symbols below are found on the configuration screen of TIGER PC.

Zero at switch on

When selected, the TIGER will automatically set its zero reading based on ambient air. When deselected the instrument will use its calibration zero.

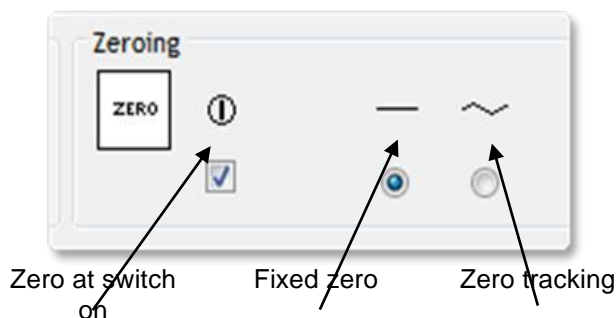

Fixed zero

When selected, TIGER uses the fixed calibration Zero. If used in conjunction with the 'Zero at switch on' feature the instrument will zero at switch on and then remain at that level.

Zero tracking

When selected, the Zero level will move negative if a cleaner ambient air is detected. This ensures 0.0 ppm is displayed in clean air and ensures sub ppb levels are always detected.

Clock

Select 24 or 12 hour format using the radial buttons. Set the time and date and tick the box on the right to set the time on your TIGER. Alternatively, tick the lower box to synchronise your TIGER with the time on your computer.

Lamp

Enables the selection of different lamp types you may have purchased to use with your instrument. Ensure that the lamp selected is the same as that fitted in your TIGER. If not, select the correct lamp from the options provided.

IMPORTANT

If you have purchased the instrument with the MiniPID Lamp (Argon)11.7eV (LA4SM700), there are a number of things related to applications that you must take into consideration before using the lamp.

1. It is important for the lamps to be stored in their desiccated vials in cool conditions (15-25°C).
2. The lamps should not be used in:
 - Chemically severe environments, i.e. those containing significant concentrations of acids and strong solvents such as dichloromethane.
 - Conditions of condensing humidity; always pass dry cool air through the instrument before storage. For long storage periods, remove the lamp and return it to the desiccated vial.
 - Physically severe environments: large temperature changes may initiate lamp failure.



Tiger PC software

11.7 eV lamps may not strike/illuminate first time and result in a 'lamp fail' alarm on the TIGER instrument, particularly if the lamps are unused for an extended period. If the TIGER instrument raises a lamp fail alarm please switch the instrument off and then switch on again. Several start cycles may be required.

11.7 eV lamps have a relatively short life partly due to the type of lamp window material. Prolonged exposure to airborne moisture slowly degrades the lamp window. Therefore the lamps should be removed from the TIGER and stored in their desiccated vial when not in use.

11.7 eV lamps have quite different characteristics to the standard 10.6 eV lamps.

In applications where the detected gas levels are expected to be below 100 ppm then only a two point calibration (Zero and 100 ppm IE) is necessary however in applications that require measurement above 100 ppm (IE) a three point calibration (Zero, 100 ppm and 1,000 ppm IE) should be carried out.

When setting up the custom calibration on TIGER PC's configuration screen select the 'Zero on Carbon Canister' option, this will ensure a near zero reading after calibration. The fixed zero option should also be selected on the configuration screen, do not select 'Zero at switch on'.

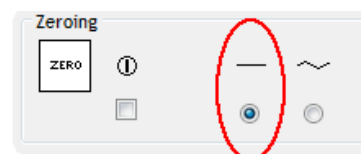
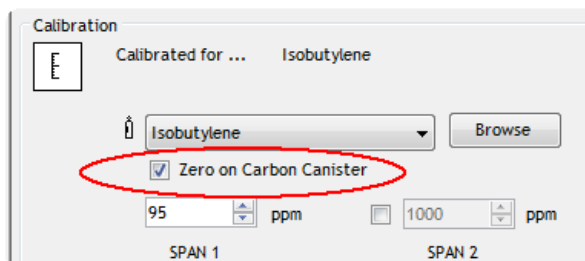

Datalog

Use this area to set the interval between readings. The minimum time permitted is one second. If you wish your TIGER to switch to sleep mode during data-logging, tick or un-tick the sleep box to enable or disable the function. The sleep mode will only operate for datalog intervals of 2 minutes or greater.

Log Full

If you select the bell symbol your TIGER will alarm when the memory log is full. Alternatively, if you wish new data to overwrite the oldest stored data in the memory and continue to store new data during data-logging, select the recycle symbol.

Zones

Use this table to define and name up to 128 separate zones. The name field is limited to eight characters including spaces.

Vibrate

To set your TIGER to vibrate under alarm conditions select the 'vibrate' symbol.

TWA STEL

Select the appropriate regulatory code to which you are working.



Tiger PC software

Calibration

Use this area to define your Custom Calibration parameters.

First connect TIGER to your PC as detailed above under 'Connecting your TIGER to a PC'.

If no gas is shown in the drop down box, browse your system to find the gas table for your instrument. Go to the location where the TIGER PC software files are saved. Follow the path:

IonScience/TIGER/software/instruments/serial no./gas table

Select the appropriate instrument number and open the Gas Table.

Select the calibration gas using the drop-down box.

TIGER PC offers a two-point calibration

(zero + span 1) or three-point (zero + span 1 + span 2) calibration. Enter the SPAN 1 concentration. For two-point calibration ensure that the box is un-ticked. For three-point calibration tick the box and enter the SPAN 2 concentration. Send this information to your TIGER. The calibration procedure is detailed under the 'Maintenance' section of this manual.

Startup Text

Enter the text you wish to appear on the startup screen of your TIGER.

Send to Instrument

When you have configured your instrument or completed your changes, send them to your TIGER by clicking the 'Send to Instrument' box. If the message 'There was a problem sending to the instrument' appears, click OK and return to the Home screen. Repeat the procedure under 'Connecting your TIGER to a PC' above. If the 'Summary' screen for your TIGER appears, visit the configuration screen again. If not, repeat the entire procedure. If your PC still fails to read or write to your TIGER seek advice from your distributor or from Ion Science Ltd.

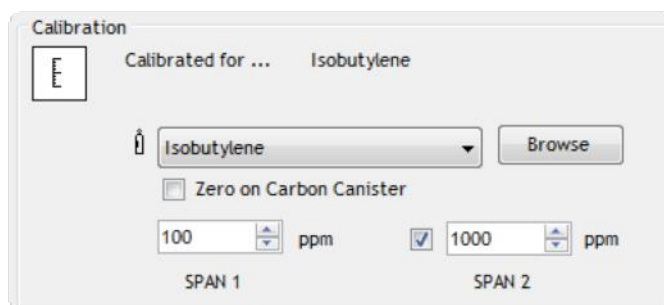



Tiger PC software

The Gas Table Screen (including setting alarm levels)

Connect your TIGER to your PC as described previously. Any fresh data-logged readings will be downloaded as the software 'reads' your TIGER.

Select 'Gas Table' from the menu to display the Gas Table.

Gas name	Abbreviation	Formula	Molecular weight	8-4 lamp	9-8 lamp	10-6 lamp
Benzyl alcohol		C7H8O	108	1.399	1.1	1.25
Benzyl chloride		C7H7Cl	127	0	0.5	0.55
Benzyl formate		C8H8O2	136	0	0.699	0.769
Biphenyl		C12H10	154	0	0.4	0.4
Bis(2,3-epoxypr...	2,3-epoxy-Pr et...	C6H10O3	130	0	2.7	3
Boron trifluoride		BF3	68	0	0	0
Bromine		Br2	160	0	0	20
Bromine pentafl...	Bromine(V)fluor...	BrF5	175	0	0	0
Bromobenzene		C6H5Br	157	0	0.6	0.699
Bromochlorome...	R 1101	CH2ClBr	129	0	0	0
Bromoethane		C2H5Br	109	0	8	5
Bromoethyl met...	Br-ethylmet. et...	C3H7OBr	139	0	2.299	2.5
Bromoform		CHBr3	253	0	0	2.799
Bromopropane, 1-		C3H7Br	123	0	2	1.299
Bromotrifluoro...	R 13B1	CF3Br	149	0	0	0
Butadiene		C4H6	54	0	0.699	0.829
Butadiene diep...	Butadiene diepox.	C4H6O2	86	0	3.599	4
Butane, n-		C4H10	58	0	0	46
Butanol, 1-		C4H10O	74	0	3.599	4.011

You are now able to modify this table and then download it to your instrument.

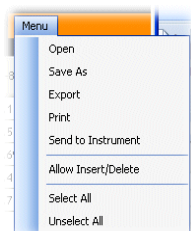

If you wish to add new gases to the table, select the 'Menu' tab, and from the drop down menu select 'Allow Insert/Delete'.

This will add an additional line at the bottom of the Gas Table which allows the user to add new gas types as below.

Xylene mixed is...		C8H10	106	0	0.43	
Xylene, m-		C8H10	106	0.4	0.439	
Xylene, o-		C8H10	106	0.689	0.6	
Xylene, p-		C8H10	106	0.62	0.55	
Xylidine, all		C8H11N	121	0	0.699	
New gas	Mix					

Upper and lower alarm levels in Survey mode can be adjusted via the Gas Table. Type the desired alarm level in the appropriate column (either high or low alarm) against the gas you wish to change.

Always save modified gas tables under a different file name, keeping the original complete.

To send the Gas Table to the instrument, select 'Send to Instrument' from the dropdown menu shown above.



Tiger PC software

The Firmware Screen

This screen displays the current firmware version installed on your TIGER. It also provides a facility to download updated versions to your TIGER.

At this point you can also check the 'View Release Notes' information which is a description of the changes in the new version as shown here.

To download a firmware update, connect TIGER to your computer as detailed previously. Ensure that your instrument is in normal Survey mode, is not in an alarm condition and that no datalogging or Health and Safety readings are being collected. Check that the battery pack is sufficiently charged (at least two bars).

IMPORTANT: The 'Firmware' upgrade process will delete all data from the instrument. To avoid loss of any data during the upgrade process, take a snapshot of the instrument before proceeding. The snapshot can be re-installed after the update process is complete.

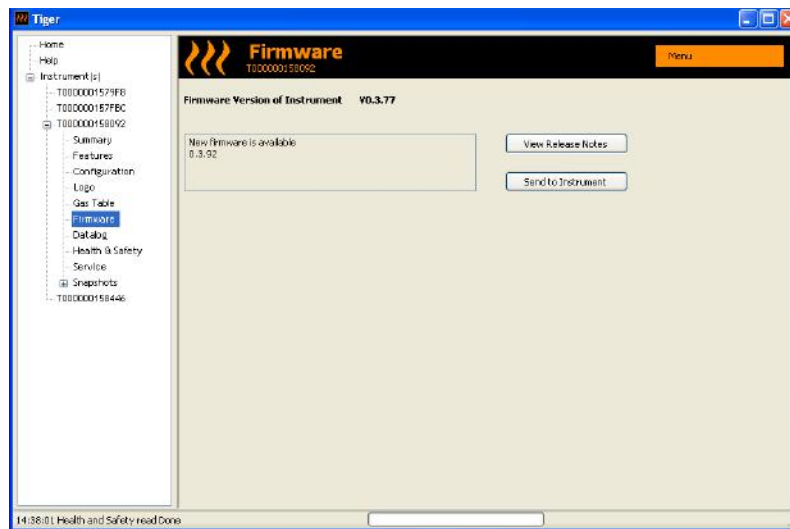

When you are ready to send the new Firmware to the instrument. Select 'Send to Instrument'.

You will now see a message that will warn you that all the data will be lost on your instrument. If you are happy to continue confirm with 'Yes'.

A 'WARNING' message will appear. If you are happy to continue confirm with 'Yes'.

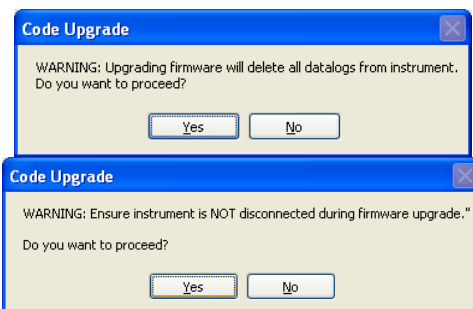



Tiger PC software

IMPORTANT: Do not attempt to operate your TIGER during the update process.

The firmware on your TIGER will be updated and the new version will be shown on the 'Firmware' screen.

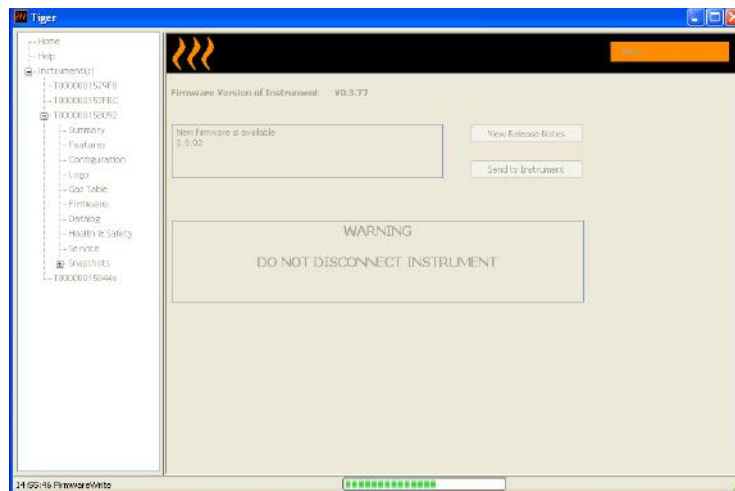

A bar at the bottom of the screen will indicate the progress of the update.

IMPORTANT: Do not disconnect the TIGER at this point. Please follow the next part before disconnecting the TIGER.

After the PC Software has completed sending the upgrade to the TIGER the instrument will then have to finish the upgrade process. The TIGER will flash the two torch LED's and the screen on the Tiger will remain blank for approximately 30 Seconds. A bar will then appear and travel across the screen. A message will be displayed as follows, 'verifying file system'. The Firmware is now installed on to the instrument and will start up automatically.





Tiger PC software

Downloading Data Logged Readings

Connect your TIGER to your PC as described previously. Any fresh data-logged readings will be downloaded as the software 'reads' your TIGER.

Go to the datalog screen and a list of the datalog sessions is presented.

Expand the datalog folder and select the session of interest.



Details of the data collected during that session are presented in numerical and graphical form.

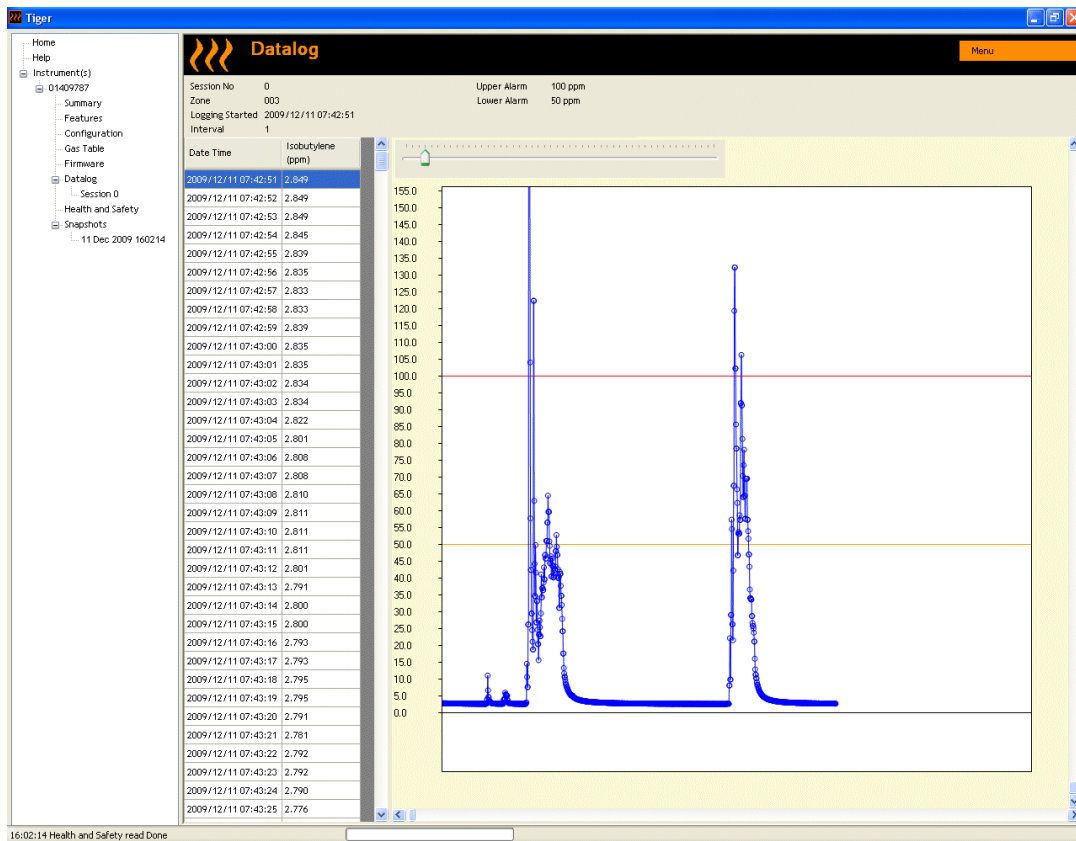

Use the menu function at the top right hand corner of the window to print, export or delete the data.

CAUTION:

The delete function deletes all logged data from your TIGER. Ensure all valuable data is exported to your PC before selecting 'Delete'.



Tiger PC software

The Health Safety Screen

This screen displays the latest Health and Safety readings held on your TIGER. Click 'Menu' then 'Export' to save this data to a file on your computer. The next readings will overwrite the data on your TIGER.

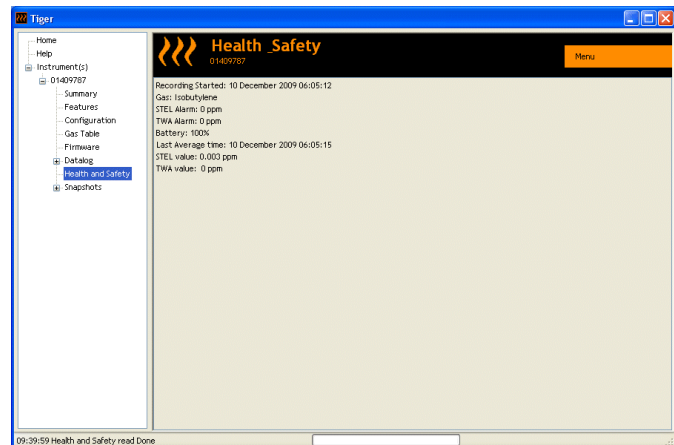

The Snapshots Screen

A snapshot records the settings and calibration data on your TIGER at any particular point in time. The 'Snapshots' screen displays a list of all those stored on your PC.

Click 'Delete' to remove a selected snapshot.

To restore the stored settings to your TIGER, first ensure that your instrument is fully booted and connected to your PC as detailed previously. Ensure that your instrument is in normal Survey mode, is not in an alarm condition and that no data logging or Health and Safety readings are being collected. Click 'Restore' against the relevant snapshot

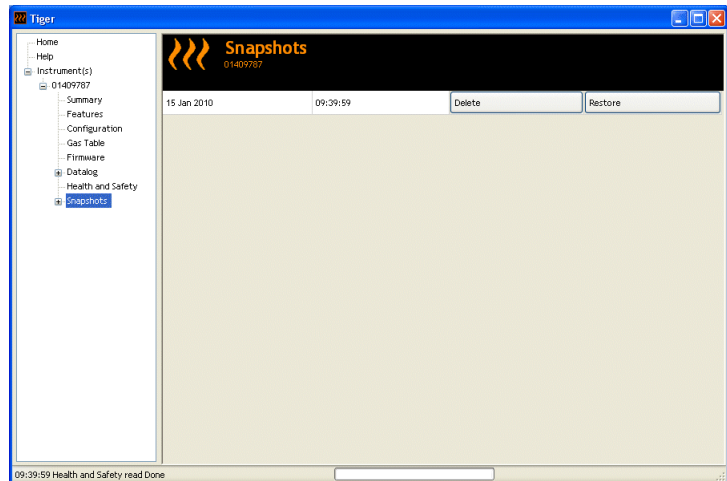

Be aware that this process will replace all setup and calibration files

On the restore screen click 'Yes'. When complete, click 'Close' and restart your TIGER. Your TIGER will now be restored to the settings and calibration data stored at the time of that snapshot.

The snapshot menu also allows review of stored data when an instrument is not attached.

Expand the menu until the latest or relevant snapshot is displayed. Double-click on the snapshot and all the data stored in that snapshot can be accessed.



Tiger PC software

Software Disclaimers

Termination of Software Licence

This License is effective until terminated. This License will terminate automatically without notice from Ion Science Ltd if you fail to comply with any provision of this License. Upon termination, you agree to destroy, delete or purge the written materials and all copies of the SOFTWARE, including modified copies, if any.

Disclaimer of Warranty

The SOFTWARE and accompanying materials (including the user's manual) are provided "as is" without warranty of any kind including the implied warranties of merchantability and fitness for a particular purpose, even if Ion Science Ltd have been advised of that purpose. Furthermore Ion Science Ltd does not warrant, guarantee, or make any representation regarding the use, or the results of the use, of the SOFTWARE or written materials in terms of correctness, accuracy, reliability, current revision, or otherwise. Ion Science Ltd specifically does not warrant the SOFTWARE after you assume operation. If the SOFTWARE or written materials are defective you, not Ion Science Ltd or its dealers, distributors, agents, or employees, assume the entire risk and costs of all necessary servicing, repair, or correction, except as stated below.

Defective CD or Memory Stick

As the only warranty under this Agreement, Ion Science Ltd warrants, to the original Licensee only, that the CD(s) or Memory Stick(s) on which the software is recorded is free from defects in materials and workmanship under normal use and service for a period of ninety (90) days from the date of delivery as evidenced by a copy of the Receipt. This limitation will apply where allowed.

Replacement of Defective CD or Memory Stick

Ion Science Ltd entire liability and the original Licensee's exclusive remedy under this agreement are at the discretion of Ion Science Ltd, to either (a) return of payment as evidenced by a copy of the Receipt, or (b) replacement of the disk or memory stick that does not meet Ion Science Ltd limited warranty and which is returned to Ion Science Ltd with a copy of the Receipt. If failure of the disk or memory stick has resulted from accident, abuse, or misapplication, Ion Science Ltd will have no responsibility to either replace the item or refund payment. Any replacement disk or memory stick will be warranted for the remainder of the original warranty period or thirty (30) days, whichever is longer. This warranty gives you limited, specific legal rights. You may have other rights in some places.

No Right to Reply

No oral or written information or advice given by Ion Science Ltd, its dealers, distributors, agents or employees will create a warranty or in any way increase the scope of the obligations of Ion Science Ltd under this agreement, and you may not rely on any such information or advice.

Limitation of Liability

Ion Science Ltd will not be liable for any direct, indirect, consequential or incidental damages (including damages for loss of business profits, business information, or possibility of such damages). The above limitation will apply where allowed under local laws.

Governing Law

The laws of the United Kingdom govern this Agreement.



Batteries

Warnings

BATTERY CHARGING:	Charge TIGER and its Lithium ion battery packs in a Non Hazardous environment only.
BATTERY REPLACEMENT:	Never replace primary Alkaline battery cells while in a potentially explosive or hazardous location. Use only Duracell Procell Alkaline batteries MN1500.
BATTERY CONNECTION:	The TIGER's Lithium ion and Alkaline battery packs have been specially designed to allow connection to the TIGER Instrument while in potentially hazardous atmospheres. The TIGER instruments ingress protection rating is reduced to IP 20 when its battery pack is removed so avoid changing batteries in dusty or wet environments.

Two battery packs are available for use with the TIGER instrument. A lithium ion Rechargeable Battery Pack **(A2)** and non-rechargeable AA Battery Pack **(A3)**, (that may be fitted with 3 AA Alkaline batteries). The rechargeable pack is recommended for normal operation with the Non-rechargeable pack available when power is not available and the use of the instrument is needed. The rechargeable pack is normally fitted as standard to the instrument when shipped.

Recharging Batteries

Ensure the TIGER is charged for at least 7 hours before using it for the first time. To ensure optimum charging the TIGER should be switched off during charging. If left on, the TIGER will take longer to charge, but should not suffer any damage. The TIGER should be charged in a non hazardous environment only.

To charge your TIGER, first connect the Charger Cradle **(A4)** to the mains, and switch on. A red light will indicate that the charger is ready. Place the TIGER in the Charger Cradle such that the contacts on the TIGER are aligned with those in the cradle. (There is no need to remove the Instrument Boot **(8)** from the TIGER during charging.) During charging, the charger will display an orange light. A green light indicates that charging is complete.

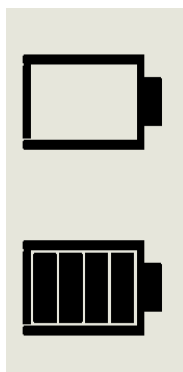

Discharged

The battery icon on the TIGER will display the level of charge.

Fully Charged

- Note:**
1. Only use the Charger Cradle supplied with your TIGER to charge your instrument.
 2. Ion Science Ltd recommends keeping your TIGER on charge at all times when not in use, as batteries can lose power over time.



Batteries

Replacement / Exchange of Battery Packs

To replace the Rechargeable Battery Pack (**A2**), proceed as follows:

- a. Ensure TIGER is switched Off;
- b. Remove the Instrument Boot (**8**) from your TIGER (this is most easily achieved by starting at the front end of the instrument (step 4 below));
- c. Release the clip at the rear end of the instrument and lift the Rechargeable Battery Pack (**A2**) away from the Instrument Body (**A1**), coincidentally sliding it slightly backwards;
- d. Reverse the procedure to install the replacement battery pack ensuring that the Boot is a snug fit around the front of the instrument and the lights are not obscured;
- e. Charge the TIGER for 7 hours before use.

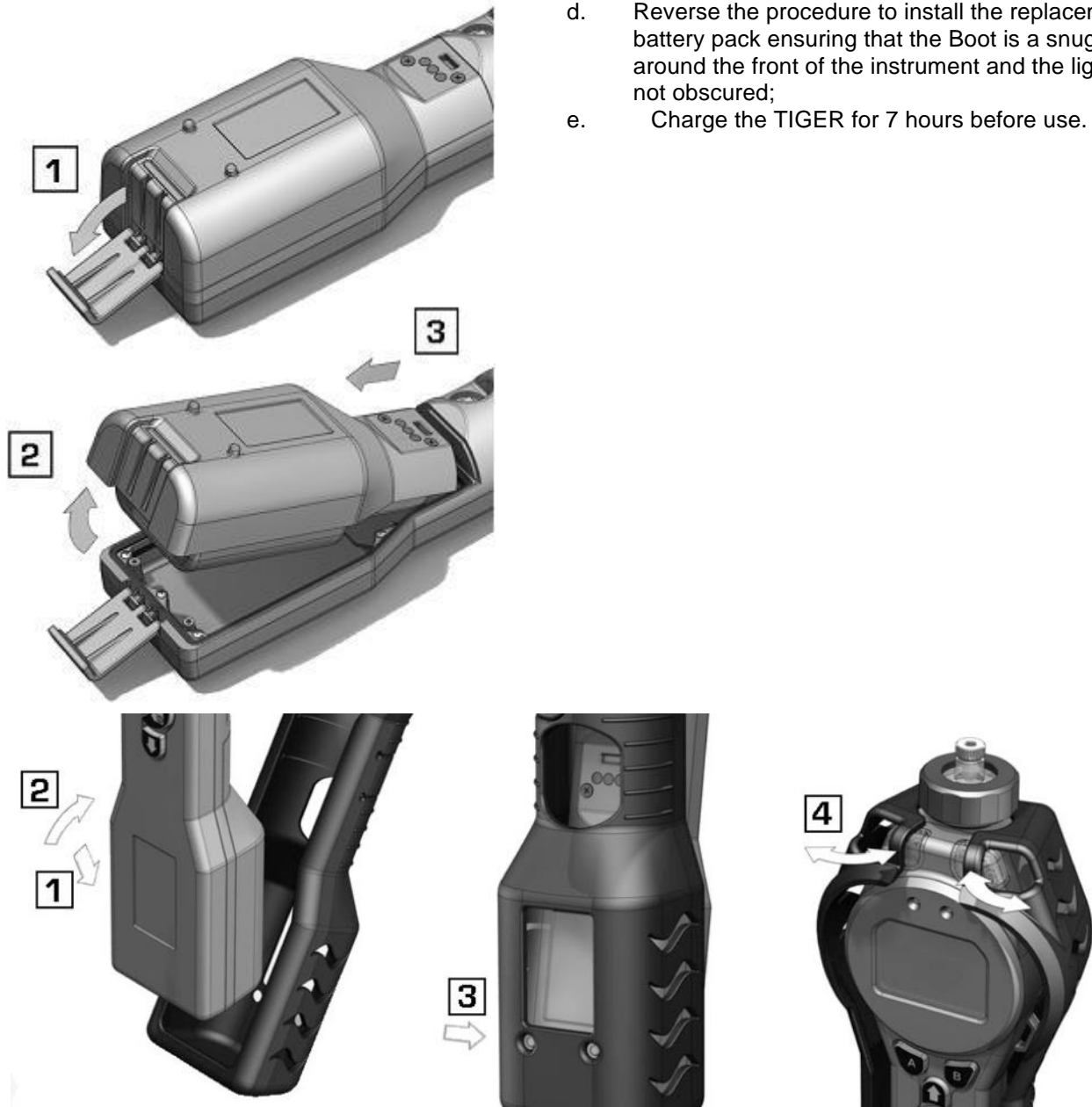

Item numbers in (bold) refer to the illustrations and parts list on page 41.



Batteries

Replacement of Non-rechargeable Batteries in Battery Pack

WARNING

BATTERY REPLACEMENT: Never replace primary Alkaline battery cells while in a potentially explosive or hazardous location. Use only Duracell Procell Alkaline batteries MN1500.

- a. Ensure TIGER is switched Off.
- b. Remove the AA Battery Pack (A3) as in (b) and (c) on page 34;

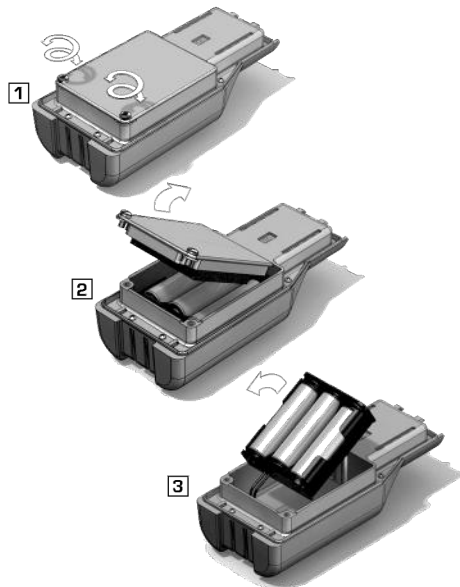

- c. Remove the screws retaining the battery cover and lift it off. This reveals a set of 3 x AA cells contained in a removable battery holder;
- d. Remove the battery holder;
- e. Replace the exhausted batteries; Use Duracell PROCELL Alkaline batteries MN1500
- f. Check all batteries have the correct polarity before replacing the battery holder;
- g. Assemble the battery holder into the AA Battery Pack (A3), refit the battery cover and fix in place using the securing screws. Replace the Instrument Boot (8) ensuring that it is a snug fit around the front of the Instrument Body (A1) and the lights are not obscured.

CAUTION:
Fitting batteries or connecting the battery pack with the wrong polarity may result in damage to the instrument!

CAUTION:
Non-rechargeable batteries must not be replaced in the field. Batteries should be loaded into the battery holder in a safe environment only. Only the assembled AA Battery Pack (A3) may be changed in the field.

CAUTION:
Do not make any connections to the USB port of this instrument whilst in a hazardous area.

Note: When loading batteries check for correct battery polarity before connecting them.

Note: Dispose of used batteries in accordance with all local and national safety and environmental requirements.



Diagnosics

Basic faults or diagnostics are presented as symbols. Should a fault occur most can be corrected by pressing **Enter** or **Esc** to clear the fault message. All fault conditions cause the TIGER to alarm.

Pump failure



Pump blocked or pump failure

The flow of gas through the instrument has fallen below 100cc/minute. Check the probe and filter for signs of blockage. Water or dirt in the probe, a bent probe, dirty filter on the inlet or blockage of the exhaust (finger over hole on the back?) can all cause low flow. If the blockage can be removed, press **Esc** to clear the alarm. If the fault persists send the instrument to your distributor for service.

Battery dead

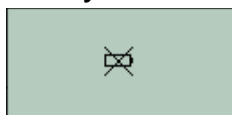

Battery low or battery failure

The TIGER will shut down when the battery level falls below 2%. Recharge the battery as instructed in the 'Batteries' section of this manual ensuring that all connections are sound and the indicator lights on the charger are in order. If the battery fails to charge, fit another battery pack if available. If using alkaline batteries, replace them. If the fault persists send the instrument and charger to your distributor for service.

Lamp out



Lamp failure

The PID lamp has failed to strike (illuminate); this may occur at switch on or during use. Switch the TIGER off and replace the lamp. See the 'Maintenance' section.

Memory full



Memory cannot receive more data

The data log memory is full. This will only happen if the Log Full box is set to 'alarm' on the TIGER PC configuration screen. Press the **Esc** key to continue, but the TIGER will no longer continue to log data. Select 'recycle' in TIGER PC and the TIGER will overwrite the oldest data and no alarm will be raised.

System error



Total system failure

The instrument's firmware is corrupted. In the unlikely event of this message appearing, contact Ion Science Ltd or your nearest authorised service centre.



Maintenance

Calibration

Ion Science Ltd recommends an annual service and calibration for users who require a traceable calibration. During this service the lamp and detector are brought back to factory specifications and new Factory Calibration data is stored.

Due to the linear output of the Ion Science PID detector, a two-point calibration is often adequate. TIGER scales its linear output across a ZERO level (clean air reference) and the SPAN 1 user defined gas concentration. For more exacting requirements, TIGER offers a three-point calibration with a higher SPAN 2 gas concentration.

TIGER offers the options of Factory Calibration or Custom Calibration. 'Factory Calibration' is set by Ion Science Ltd during instrument manufacture or on re-calibration. 'Custom Calibration' can be set by the instrument user.

For **Factory Calibration** contact Ion Science Ltd or your distributor.

'Factory Calibration' offers a safe set of three-point calibration data. This should be used if the custom calibration fails and will keep the unit working until a good custom calibration is completed.

For **Custom Calibration**, first set up the parameters in TIGER PC - see the 'TIGER PC Software' section of the manual.

TIGER allows you to custom calibrate using any gas from the Gas Table at any concentration from 10ppm. You will need a cylinder of the selected gas at each of the chosen concentrations. Each cylinder should be regulated for a flow rate above 250ml/min.

Have the cylinder(s) of gas, regulator(s) and the zero carbon filter (included in the Calibration Kit (A-861418) for your TIGER) on hand before starting the procedure. Alternatively a known clean air supply may be used as the 'zero' gas. Please ensure you are familiar with the entire calibration procedure before attempting to calibrate your TIGER.

Note: The calibration of your TIGER must be carried out in a clean air environment. Ensure all parts of the Calibration Kit are available and ready for use.

Never calibrate the zero with the span gas connected.

Press the **Options** soft key  on your TIGER to access the adjustable features.

Then use the **Up** or **Down** key to select calibration.  Press **Enter** to confirm selection.

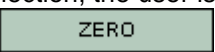
Select **Custom Calibration**  and press **Enter** to confirm. On confirming the selection, the user is presented with a 15 second count down. 

Remove both caps from the Carbon Filter Assembly (A-31057) and then fit onto the probe of your TIGER. Press **Enter** to start the 'zero' countdown. At the end of the count down a tick '✓' will appear, indicating that the Zero has been accepted. Disconnect the Carbon Filter Assembly and replace the cap ends. The useful life of the Carbon Filter Assembly will be shortened if the Carbon Filter Assembly is open to atmosphere for prolonged periods.





Maintenance

Press **Enter** again and the gas and concentration for Span 1 (previously set up in TIGER PC) are displayed along with a 15 second countdown. **SPAN 1** Attach the 'Span 1' gas using the Calibration Adaptor (861476) supplied in the Accessory Box (A-861267) (see 'Accessories') and press **Enter** to start the Span 1 countdown. At the end of the count down a tick '✓' will appear, indicating that the Span 1 has been accepted. For two-point calibration, press **Enter** and the calibration is complete.

For three-point calibration, press **Enter** to display the gas and concentration for Span 2 (previously set up in TIGER PC) along with a 15 second countdown. **SPAN 2** Attach the 'Span 2' gas and press **Enter** to start the Span 2 countdown. At the end of the count down a tick '✓' will appear, indicating that the Span 2 has been accepted.



Press **Enter** again and the calibration is complete.

Inlet Nozzle (Part number: 861443)

Should the Inlet Nozzle become contaminated or damaged, replacement Inlet Nozzles may be obtained from your distributor or from Ion Science Ltd. Please note that a small O-Ring at the base of the Inlet Nozzle ensures the Inlet Nozzle is sealed, this can be seen in the transparent Filter Clamp when the Inlet Nozzle is removed. The Inlet Nozzle can be removed for cleaning or replacement by unscrewing it from the transparent Filter Clamp.

Refit the Inlet Nozzle using fingers only, avoid using tools as this may damage the filter housing. To ensure the assembly is sealed, place a finger over the Inlet Nozzle to block the flow while the instrument is running. A flow alarm should occur if sealed correctly.



New probe assembly

Inlet Nozzle (Part number: 880207)

The Tiger inlet probe design was updated for a stronger design to ensure a longer working life. These probes are supplied as standard on Tiger instruments supplied from January 2016. These probes can be used on older instruments however an alternative filter clamp and seal are required. An upgraded kit is available.

Probe upgrade kit: A-880214

PTFE Filter Disc (861221)

The Filter Disc should be changed after every 100 hours of use. This frequency should be increased for dusty or moisture laden environments or whenever the filter appears 'dirty' when viewed through the transparent upper surface of the Filter Clamp.

Filter Disc changing should be conducted in a suitably clean environment, with clean hands and equipment to avoid contamination of the new Filter Disc.

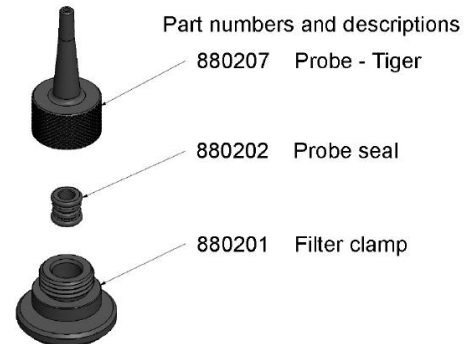

To change the Filter Disc, unscrew the Filter Housing Cap, lift off the Filter Clamp and O-Ring and lift the Filter Disc from the Instrument Body. Carefully place a new Filter Disc into the Instrument Body. **(Under no circumstances should a Filter Disc be used once it has been removed.)** Replace the Filter Clamp, ensuring the locating lugs are correctly positioned in the cut-outs in the Instrument Body and that the O-Ring is correctly seated. Replace the Filter Housing Cap. Do not over-tighten.



Maintenance

PID Sensor/Lamp Replacement and Cleaning

When using your TIGER in conditions of high ambient humidity, the PID may show unexpected readings appearing to increase. This occurs due to dust or other small particles within the detector becoming hydrated with humidity. This causes these particles to conduct a signal between the electrodes. The problem can be resolved by the user in the field using the procedure below and a can of computer duster air.

In normal use the lamp should be cleaned after every 100 hours of use (based on 30 ppm for 100 hours). Reduce this if TIGER is used in heavily gas contaminated environments. Please note that some esters, amines and halogenated compounds may accelerate window fouling; in these cases cleaning may be required after every 20 hours of use. Cleaning frequency will also depend upon alarm levels set and prevailing environmental conditions.

CAUTION!

The TIGER is a sensitive detector. Internal components must be handled with clean hands and clean tools. The TIGER lamp is fragile. Handle with great care. Never touch the window and do not drop!!

To remove the MiniPID 2 Sensor for cleaning or lamp replacement, first ensure that the TIGER is turned off and that you are in a clean environment such that the sensor parts will not be contaminated by dust, oil or grease. Remove the Sensor Cover (see image on right). The centre screw may be turned with a small coin or a suitable flat bladed screwdriver.



Ensure that the Sensor Seal, on the inside of the Sensor Cover is not disturbed.

Carefully lift the MiniPID 2 Sensor from the Instrument Body, ensuring that the two Inlet/Outlet Seals remain in place in the Instrument Body.

Using the special Removal Tool MiniPID 2 Stack (846216) provided, locate its 'prongs' in the slots in the side of the MiniPID 2 Sensor body. Using the forefinger to restrain the sensor, (the internal parts are spring-loaded and careless disassembly will leave you hunting for the spring!) squeeze the tool to release the lamp housing.



The lamp may now be removed.

To replace the lamp or install a new one, reverse the procedure, ensuring the seals are all in place. When replacing the Sensor Cover ensure that the markers are aligned correctly and that the cover is a snug fit. Sealing of the Sensor Cover against the PID is important, the cover must be tightened to 70 cN.m +/- 10%.

The instrument MUST be re-calibrated after fitting a replacement or cleaned lamp.

CAUTION!

Never refit a damaged lamp!



Maintenance

Lamp Cleaning

The TIGER PID relies on an ultraviolet light source ionising VOC gases as they pass across the lamp window. This process may result in a very fine layer of contamination appearing on the detector window that must be removed on a regular basis.

CAUTION!

The TIGER is a sensitive detector. Internal components must be handled with clean hands and clean tools. The TIGER lamp is fragile. Handle with great care!

First ensure that the TIGER is turned off and that you are in a clean environment such that the sensor parts will not be contaminated by dust, oil or grease.

Remove the lamp as detailed on page 39.

Inspection of the lamp may reveal a layer of contamination on the detection window that presents itself as a 'blue hue.' To check for confirmation, hold the lamp in front of a light source and look across the window surface. Clean the window using the PID Lamp Cleaning Kit (A-31063) supplied.

USE OF PID Lamp Cleaning Kit A-31063

The container of cleaning compound contains Aluminium Oxide as a very fine powder (CAS Number 1344-28-1).

A full material safety data sheet MSDS is available on request from Ion Science Ltd. The key issues are listed below:

Always replace the lid after using the cleaning compound.

Hazard identification:

- May cause irritation of respiratory tract and eyes.

Handling:

- Do not breathe vapour/dust. Avoid contact with skin, eyes and clothing;
- Wear suitable protective clothing;
- Follow industrial hygiene practices: Wash face and hands thoroughly with soap and water after use and before eating, drinking, smoking or applying cosmetics;
- The Compound has a TVL(TWA) of 10 mg/m³.

Storage:

- Keep container closed to prevent water adsorption and contamination.

To clean the lamp:

1. Open the vial of Aluminium Oxide polishing compound. With a clean cotton bud collect a small amount of compound;
2. Use this cotton bud to polish the PID lamp window. Use a circular action applying light pressure to clean the lamp window. Never touch the lamp window with fingers;
3. Continue polishing until an audible "squeaking" is made by the cotton bud with compound moving over the window surface (usually within fifteen seconds);
4. Remove the residual powder with short blast of air from the can of air duster;
5. The instrument MUST now be re-calibrated.





Tiger parts

Tiger main assembly

ITEM	DESCRIPTION	PART No.	QTY
A1	INSTRUMENT BODY	A-861274	1
A2	RECHARGEABLE BATTERY PACK	A-861240	1
A3	AA BATTERY PACK	A-861241	1
A4	CHARGER CRADLE	A-861220	1
A5	SENSOR COVER	A-861259	1
A6	MINIPID 2 SENSOR	MP65368KV2	1
7	SENSOR GASKET	861203-9	1
8	INSTRUMENT BOOT	861205	1
9	SENSOR SEAL	861214	1
10	INLET/OUTLET SEAL	861215	2
11	FILTER HOUSING CAP	861218	1
12	FILTER CLAMP	861219	1
13	FILTER DISC	861221	1
14	INLET NOZZLE	861443	1
15	O-RING	5/OV-02	1
16	O-RING	5/OV-04	1

Front end filter assembly

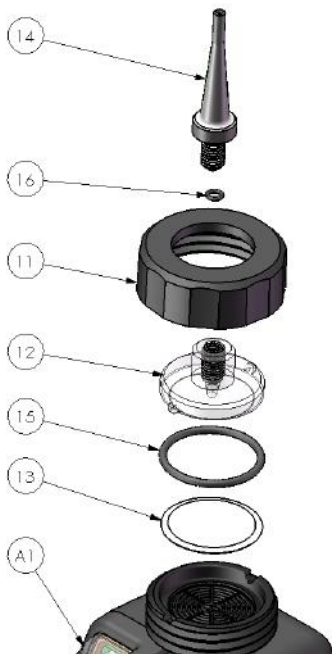

New probe assembly

Part numbers and descriptions

880207

Probe - Tiger

880202

Probe seal

880201

Filter clamp

New probe assembly supplied on Tiger from January 2016



Accessories

Ion Science Ltd has developed an exclusive range of high quality accessories to compliment the TIGER. Please see a selection of these below:

Part Number	Accessory Description
1/jawu-01	2.1mm DC Jack - Cigar Lighter Plug Car Charger Lead – Allows the Charger Cradle (A4) to be powered from a standard vehicle cigar lighter (12 volt only)
861214	PID Sensor Seal (9) – Seal between the MiniPID 2 Sensor (A6) and the Sensor Cover (A5)
846216	Removal Tool MiniPID Stack – Used to remove Stack / Pellet from the MiniPID 2 Sensor (A6)
861205	Protective, Removable Rubber Boot (8) – Supplied with every TIGER, this is a replacement
861219	Filter Clamp (12) – Transparent clamp that covers the PTFE filter and accepts the Inlet Nozzle (14)
861230	USB Cable – Angled B Connector – Supplied with every TIGER, this is a replacement
861266	Leather instrument holster – TIGER can be carried on a belt around the waist allowing hands free operation
861412	Leather instrument harness – TIGER can be carried against upper body allowing hands free operation
880207	Inlet probe – new stronger design. Standard from January 2016
880202	Probe seal (used with 880207 above) Standard from January 2016
880201	Filter clamp (used with 880207 above) Standard from January 2016
A-880210	Probe upgrade kit – Contains 880207, 880202 and 880201 (above)
861443	Inlet Nozzle (14)
A/OV-04	O’ring for use with Inlet Nozzle (14)
A-861474	O’rings for use with Inlet Nozzle (14) pack of 5
861476	Calibration Adaptor – Must be used when calibrating using flow regulators
A-31057	Carbon Filter – Used during calibration to set a zero
A-31063	PID Lamp Cleaning Kit- Contains Alumina powder and 40 cotton buds
A-861413	5m Extension Hose – Replaces the standard probe, pipe material: PTFE
A-861414	10m Extension Hose – Replaces the standard probe, pipe material: PTFE
A-861415	Diluter – Dilutes immediate sample with ambient air
A-861406	Flexible Probe Assembly – 300mm, replaces the standard probe, internal pipe material: PTFE
A-861240	Lithium ion battery pack, intrinsically safe – Replacement / spare
A-861241	Alkaline battery pack, intrinsically safe. 3 x AA batteries included – Replacement / spare
A-861267	Accessory box as supplied with the TIGER – Includes carbon filter, lamp cleaning kit, PID Stack / Pellet removal tool, lanyard, calibration adaptor and PID sensor seal
A-861472	Pack of 10 PTFE Filter Discs
A-861511	Anti vibration charger cradle – Allows wall mounting of vehicle charging, includes charge cradle



LA4TM600	10.6eV Lamp
LA4SM700	11.7eV Lamp

For more information please visit www.ionscience.com/Tiger and select Accessories.

Instrument warranty and service

Warranty

Standard Warranty can be extended to up to 5 years on the TIGER when registering your instrument via our website: www.ionscience.com/instrument-registration To receive your Extended Warranty, you need to register within one month of purchase (Terms and Conditions apply).

To register your TIGER instrument, simply fill in the online form. You will need to enter your instrument serial number to hand. The serial number is located on the front label of the instrument, towards the bottom end of the unit. Beneath the bar code, there will be a number beginning with T- followed by 6 digits. (E.g.T-123456).

You will then receive a confirmation email that your Extended Warranty Period has been activated and processed.

Full details, along with a copy of our Warranty Statement can be found by visiting: www.ionscience.com/instrument-registration

Service

Ion Science Ltd also offers a number of service options for your TIGER that allows you to choose the instrument cover to best suits your requirements.

At Ion Science Ltd we recommend that all of our gas detection instruments be returned for service and factory calibration once every 12 months.

Contact Ion Science Ltd or your local distributor for service options in your area.

Find your local distributor by visiting: www.ionscience.com

Contact Details:

Head Office (UK)

Ion Science Ltd
The Way, Fowlmere
Cambridge
SG8 7UJ
UK
Tel: +44 (0)1763 207206
Fax: +44 (0) 1763 208814
Email: info@ionscience.com
Web: www.ionscience.com

US Corporate HQ

Ion Science Inc
4153 Bluebonnet Drive, Stafford
Texas
77477
USA
Tel: +1 877 8647710
Email: info@ionscienceusa.com
Web: www.ionscience.com

German Office

Ion Science Messtechnik GMBH
Laubach 30
Metmann-Neandertal
40822
GERMANY
Tel: +49 2104 14480
Fax: +49 2104 144825
Email: info@ism-d.de
Web: www.ism-d.de

Italian Office

Ion Science Italia
Via Emilia 51/c
40011 Anzola Emilia
Bologna
ITALY
Tel: +39 051 0561850
Fax: +39 051 0561851
Email: info@ionscience.it
Web: www.ionscience.it



Technical specification

Response time:	T90 < 2 second	
Detectable Range:	1 ppb – 10,000 ppm & ppb to 20,000ppm for Specific Gases	
Resolution:	+/- 1 ppb	
Accuracy:	+/- 5% displayed reading +/- one digit	
Linearity:	+/- 5% displayed reading +/- one digit	
Battery:	Lithium ion:	24 hours
	Alkaline (Duracell Procell MN1500):	8.5 hours
	Including date / time:	120,000
Data log:	Including date / time: 120,000	
Alarm visual:	Flashing Red and Amber LED	
Alarm audible:	95 dBA @ 30 cm	
Flow Rate:	≥ 220 ml/min in Ambient conditions	
Temperature:	Operating:	-20 to 60 °C (-4 to 140 °F)
	Storage:	-25 to 60 °C (-13 to 140 °F)
	Certified to:	-15 to 45 °C (-5 to 140 °F)
Dimensions:	Instrument: 340 x 90 x 60 mm	
Weight:	Instrument: 0.720 kg (1.6 lb)	
Materials:	Instrument:	Anti-static PC/ABS (Polycarbonate/ Acrylonitrile Butadiene Styrene)
	Rubber Boot:	Anti-static TPE (Thermoplastic Polyolefin Elastomeric)



Manual log

Manual version	Amendment	Issue Date	Instrument Firmware	PC Software
1.0	First issue	15/01/2010	V 0.3.40	V 1.0.0.18
1.4	Updated filter replacement instructions on page 34.	9/4/2010	V 0.3.49	V 1.0.0.26
1.5	Addition of ATEX information and new probe graphics	11/05/2010	V0.0.57	V 1.0.0.30
1.6	Addition of IECEx number on page 4	17/06/2010	V0.0.63	V 1.0.0.31
1.7	Instrument Warranty Information added to page 41 Accessory images added to page 39-40 Images added on pages 33 and 34	21/07/10	V0.0.63	V 1.0.0.31
1.8	Pg 38 – Part Numbers LA4SB600 & LA4SM600 have been deleted and replaced with LA4TM600, LA4TB600 & LA4SM700	30/09/10	V0.0.63	V 1.0.0.31
1.9	Page 21 – New screen shot of PC software. New tick box added for 'Sleep during PC connect' mode. Page 33 – carbon filter adaptor added in instructions. Page 33 – Note added, 'Never calibrate the zero with the span gas connected'	10/10/10	V0.0.74	V 1.0.0.31
2.0	Page 41 – Accessory added, Sensor seal .	12/11/10	V0.0.74	V 1.0.0.33
2.1	Page 37 – Part number 5/OV-02 changed from 5/OV-04	13/01/11	V.0.0.77	V 1.0.0.39
2.2	Battery Charging & Proper use added. Page 3 Field replacement of alkaline battery pack note added. Page 8 Information screens updated to include features screen. Page 16 Firmware upgrade screen updated. Page 25	25/02/11	V.0.0.85	V.1.0.0.42
2.3	Battery Charging note added. Page 30 Two battery packs note added. Page 30 11.7eV lamp information and spec added to page 22 Page 4 & 7 updated to correct Quality Management System. Page 7 Responsibility for use updated and Legal Notice added	03/03/11	V.0.0.85	V.1.0.0.42



Manual log

Manual version	Amendment	Issue Date	Instrument Firmware	PC Software
2.4	Front cover, Issue updated to V2.4 Servicing warnings and Intrinsically safe note added to warnings section on page 3 Page 12, Softkey note added Page 15, Stealth mode added Page 19 & 20, PC Software upgrade Updated Page 23, Lock Softkeys note added Page 26 & 27, TIGER Firmware upgrades updated	29/03/2011	V0.3.93	V1.0.0.45
2.5	Lamp information added on page 25 Page 37, Reference to Carbon Filter Adaptor deleted as this is not used. Page 44, A-861229, Carbon Filter Adaptor deleted.	07/06/2011	V0.3.93	V1.0.0.45
2.8	Manual part number added (front cover) Option icon updated - ppm & lamp added (p.14) Unit and lamp icons and text added (p. 15) Entire table checked & updated with icons and text (p. 16) Option icon updated - ppm & lamp added (p.35)	18/10/2012	V0.4.17	V1.0.0.63
2.9	Outer front cover updated. Instrument registration note added to inside front cover.	29/01/2013	V0.4.17	V1.0.0.63
3.0	Page 15 – Removed temperature icon	19/04/2013	V0.4.20	V 1.0.0.70
3.1	SW & FW upgrade SPAN 2 adjusts to 5,000 ppm.	23/07/2013	V0.4.22	V 1.0.0.73
3.2	Accessory clarification 861443/5/OV-04 and A861474. Page 41	13/02/2014	V0.4.22	V 1.0.0.73
3.3	Instrument warranty text amended to direct customers to the serial number on the front label of the instrument – not the IRN number Page 42 Tiger PC software updated Declaration of conformity updated and warnings in French added	12/08/2014	V0.4.28	V 1.0.0.73
		23/12/2014	V0.4.28	V 1.0.0.75
		19/06/2015	V0.4.33	V1.0.0.76
3.4	New inlet probe pages 38,41 and 42.	27/01/2016	V0.4.33	V1.0.0.77
3.5	Added torque setting page 39	15/04/2016	V0.4.33	V1.0.0.77
3.6	MiniPID changed to MiniPID 2 throughout. Declaration of Conformity page 5. US postal address page 44. Responsibility for use page 8.	28/04/2016	V0.4.33	V1.0.0.77