



## INSTRUCTION MANUAL

MODEL M1 POINT GAS DETECTOR FOR  
COMBUSTIBLE, TOXIC & OXYGEN MONITORING

(REVISION 4.6)



PH. 409-927-2980 FAX 409-927-4180  
2513 HWY 646, Santa Fe, TX 77510  
Website: <http://www.gdscorp.com>

|  |    |
|--|----|
| SECTION I.....   | 1  |
| 1.1 DESCRIPTION:.....  | 1  |
| 1.2 SPECIFICATIONS:.....   | 2  |
| 1.2.1 CATALYTIC BEAD SENSOR VOLTAGE (M1/LEL): .....              | 2  |
| 1.2.2 SIGNAL OUTPUT:.....  | 3  |
| 1.2.3 POWER SUPPLY:.....   | 3  |
| 1.2.4 CALIBRATION RANGE: .....                                   | 3  |
| 1.2.5 CALIBRATION RESOLUTION: .....                              | 3  |
| 1.2.6 ACCURACY:.....   | 3  |
| 1.2.7 AMBIENT TEMPERATURE RANGE: .....                           | 3  |
| 1.2.8 TEMPERATURE DRIFT: .....                                   | 3  |
| 1.2.9 APPROVALS.....   | 3  |
| 1.2.10 HOUSING:.....   | 3  |
| SECTION II.....  | 4  |
| INSTALLATION.....  | 4  |
| 2.1 MOUNTING:.....   | 4  |
| 2.2 ELECTRICAL CONNECTIONS: .....                                | 4  |
| SECTION III.....   | 5  |
| OPERATING PROCEDURES .....                                       | 5  |
| 3.1 'NORMAL MODE' OPERATION:.....                                | 5  |
| 3.2 OVER-RANGE:.....   | 6  |
| 3.3 ROUTINE CALIBRATIONS USING 'CAL MODE':.....                  | 6  |
| 3.3.1 READING SENSOR ZERO / SPAN SETTINGS ON THE LCD: .....      | 7  |
| 3.4 UNITY GAIN MODE:.....  | 7  |
| 3.5 DELAY MODES: .....   | 7  |
| 3.5.1 POWER UP DELAY: .....                                      | 8  |
| 3.5.2 'CAL MODE' EXIT DELAY: .....                               | 8  |
| 3.5.3 AUTOMATIC 'CAL MODE' EXIT TIMER:.....                      | 8  |
| 3.5.4 ABORTING THE DELAY MODES: .....                            | 8  |
| 3.6 FAULT CONDITIONS: .....                                      | 8  |
| 3.7 LCD METER SPAN SETUP MODE: .....                             | 9  |
| 3.8 4-20MA SOURCE MODE:.....                                     | 9  |
| 3.9 "END OF SENSOR LIFE" INDICATION .....                        | 9  |
| SECTION IV.....  | 10 |
| MODEL M1 LEL CATALYTIC BEAD SENSORS .....                        | 10 |
| 4.1 GENERAL DESCRIPTION: .....                                   | 10 |
| 4.1.1 SENSOR POISONING: .....                                    | 10 |
| 4.2 M1/LEL INITIAL START-UP AND CALIBRATION PROCEDURE: .....     | 10 |
| 4.2.1 SENSOR VOLTAGE ADJUSTMENT (INITIAL CALIBRATIONS): .....    | 11 |
| FIGURE 4.1 .....   | 11 |
| 4.2.2 MONITORING VOUT TEST POINT (INITIAL CALIBRATIONS): .....   | 11 |
| 4.2.3 BALANCE ADJUSTMENT (INITIAL CALIBRATIONS): .....           | 12 |
| 4.2.4 M1/LEL FIXED GAIN ADJUSTMENT (INITIAL CALIBRATIONS): ..... | 12 |
| 4.3 LEL SENSOR FAULT SUPERVISION:.....                           | 13 |
| 4.4 SENSOR REPLACEMENT: .....                                    | 13 |
| SECTION V.....   | 15 |
| MODEL M1/EC FOR ELECTROCHEMICAL SENSORS .....                    | 15 |
| 5.1 GENERAL DESCRIPTION: .....                                   | 15 |
| 5.2 M1/EC INITIAL START-UP AND CALIBRATION PROCEDURE:.....       | 16 |
| 5.2.1 SENSOR RESPONSE COEFFICIENT:.....                          | 16 |
| 5.2.2 M1/EC INITIAL FIXED GAIN ADJUSTMENT: .....                 | 16 |
| 5.3 MISSING ELECTROCHEMICAL SENSOR FAULT SUPERVISION: .....      | 18 |
| 5.4 M1/EC/BIAS MODEL SUPPORTS BIASED SENSOR TYPES:.....          | 18 |
| 5.5 SENSOR REPLACEMENT: .....                                    | 18 |
| SECTION VI.....  | 18 |
| OPTIONAL FEATURES.....   | 18 |
| 6.1 OPTIONS GENERAL DESCRIPTION:.....                            | 18 |
| 6.2 ISOLATED 4-20 MILLIAMP OUTPUT OPTION: .....                  | 19 |

# **MODEL M1 GAS DETECTOR**

*GDS Corp.*

|                                    |   |    |
|------------------------------------|---|----|
| 6.3                                | MODBUS® RS-485 SERIAL INTERFACE OPTION: .....   | 19 |
| 6.3.1                              | RTU ADDRESSES AND TERMINATING RESISTORS: .....  | 21 |
| 6.3.2                              | MODBUS DATA REGISTERS AND FUNCTION CODES: ..... | 22 |
| 6.3.3                              | MODBUS CONFIGURATION SOFTWARE: .....            | 24 |
| 6.4                                | ALARM RELAYS OPTION: .....                      | 24 |
| 6.4.1                              | LATCHING ALARMS: .....                          | 25 |
| 6.4.2                              | FAIL-SAFE ALARMS: .....                         | 26 |
| SECTION VII .....                  |   | 27 |
| FACTORY SERVICE AND WARRANTY ..... |   | 27 |
| 7.1                                | FACTORY SERVICE: .....                          | 27 |
| 7.2                                | WARRANTY: .....                                 | 27 |
| SECTION VIII .....                 |   | 28 |
| PHYSICAL DIMENSIONS .....          |   | 28 |

**SECTION I**

**1.1 DESCRIPTION:**

This manual describes the GDS Corp. microprocessor based M1 Gas Detector with Non-Intrusive calibration. Two models of the M1 are described within this manual. The M1/LEL accepts catalytic bead combustible sensors and the M1/EC accepts electrochemical toxic and oxygen sensors. Section 4 discusses the M1/LEL and section 5 the M1/EC. Options available to enhance M1 performance are described in section 6 of this manual. These include an isolated 4-20mA output, an RS-485 Modbus® serial interface, or, an alarm providing 5 amp form C relays for FAULT, WARN and HIGH alarm conditions.

The Model M1/LEL & M1/EC Gas Detectors accept a wide range of gas detection sensors. These sensors connect to the M1 electronics via the GDS Corp. Universal Sensor Head. A 4-20mA output and 3½ digit LCD readout provide analog and visual indications of gas concentration and events such as calibrations and sensor failures. The magnetic keypad allows complete "end to end" calibrations without opening the explosion-proof enclosure. This is especially useful when the area is classified as potentially hazardous and declassification is required to open enclosures. FAULT conditions, such as catalytic bead sensor failures, missing EC sensor, or negative drift below 2.4mA (-10% of full scale), are detected and indicated by the M1. FAULT conditions are indicated by 0mA at the 4-20mA output, **FLt** displayed on the LCD and by flashing the FAULT red LED.

The only tool required to calibrate the M1 is a small magnet provided on a key chain. The LCD readout displays appropriate engineering units such as percent of LEL (lower explosive limit) or PPM (parts per million). Section 3.7 describes how to configure the full-scale range of the M1's LCD readout. Prior to calibration, the M1 must be placed in CAL MODE by holding the magnet over the CAL key on the front panel. The M1 responds by briefly overwriting the display with '**CAL**', and illuminating a left arrow on the LCD. During CAL MODE the 4-20mA output is held at 1.5mA to prevent alarms or other instrumentation from being affected by calibration levels. Calibration is performed by appropriately exciting the sensor and holding the magnet over the UP/DOWN ZERO or UP/DOWN SPAN keys as

## MODEL M1 GAS DETECTOR

*GDS Corp.*

needed to obtain correct readings on the LCD readout. ZERO and SPAN keys do not interact when the zero adjustment is performed first. The UNITY key places the M1 in UNITY GAIN MODE with ZERO / SPAN keys returned to the center of their adjustment range and offset set to zero and gain set to one. Range of adjustment for the magnetic controls is limited to  $\pm 15\%$  for ZERO and .5-2 for SPAN. Current offset and gain settings may be viewed without entering the CAL MODE. The UP SPAN key displays offset and DOWN SPAN the gain. This is useful for tracking sensor sensitivity that may deteriorate with age. When sensitivity falls to half of when the sensor was new, requiring doubling the gain, it is approaching time to replace that particular sensor.

A non-volatile memory device provides indefinite battery backup of calibration values during power interruptions.

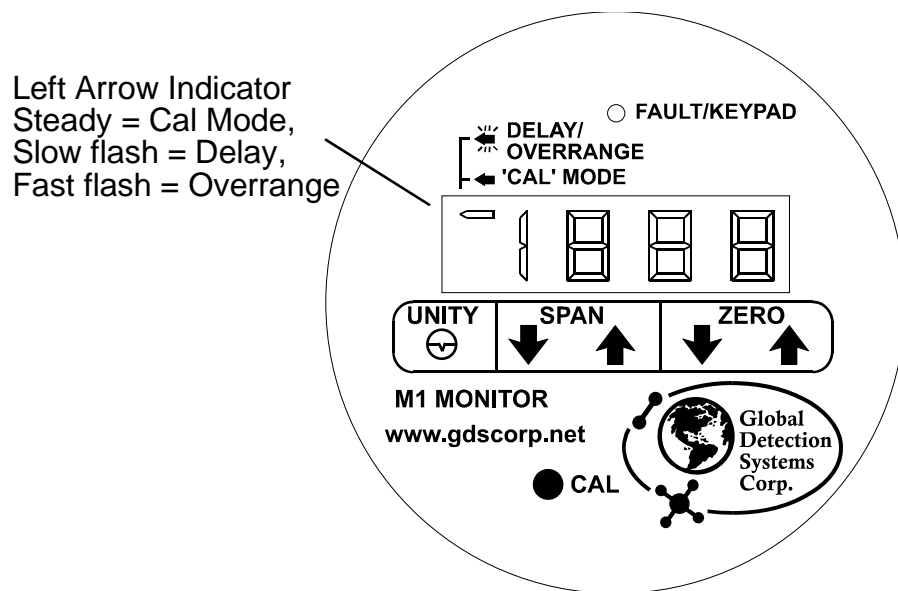

**M1 FRONT PANEL**

**FIGURE 1.1**

### **1.2 SPECIFICATIONS:**

#### **1.2.1 CATALYTIC BEAD SENSOR VOLTAGE (M1/LEL):**

NOMINAL 2 VOLTS ACROSS THE SENSOR

## MODEL M1 GAS DETECTOR

*GDS Corp.*

### **1.2.2 SIGNAL OUTPUT:**

4-20mA INTO 750 OHMS MAX WITH 24VDC POWER STANDARD

### **1.2.3 POWER SUPPLY:**

18-30VDC; 4 WATTS @ 24 VDC

### **1.2.4 CALIBRATION RANGE:**

ZERO -  $\pm 15\%$  OF FULL SCALE

SPAN - TURN UP TO GAIN OF 2, DOWN TO GAIN OF .5

### **1.2.5 CALIBRATION RESOLUTION:**

.1% OF FULL SCALE

### **1.2.6 ACCURACY:**

$\pm .1\%$  OF FULL-SCALE  $\pm 1$  COUNT

### **1.2.7 AMBIENT TEMPERATURE RANGE:**

-40 TO +60 DEGREES CENTIGRADE

### **1.2.8 TEMPERATURE DRIFT:**

LESS THAN .1% PER DEGREE C OVER AMBIENT TEMPERATURE RANGE

### **1.2.9 APPROVALS**

CSA C22.2 No 152 FOR COMBUSTIBLES & Cl. I, DIV.1, GROUPS B, C, D.

CSA File # = 211579 (WWW.CSA-INTERNATIONAL.ORG).

### **1.2.10 HOUSING:**

EXPLOSION-PROOF CLASS 1, GROUPS B, C, D AND CLASS 2, GROUP E, F, G WITH CSA AND FM APPROVAL

# MODEL M1 GAS DETECTOR

GDS Corp.

## SECTION II

### INSTALLATION

#### 2.1 MOUNTING:

The M1 is packaged in an explosion-proof housing with two 3/4 inch N.P.T. conduit hubs located in line and across the housing from each other (see Figure 8.1). This housing has symmetrical mounting holes for the electronics drilled so conduit hubs may be oriented across the bottom, top, left side or right side. Simply mount the housing as desired and remove the four screws holding the M1 I/O printed circuit board in place. Orient the I/O PCB so the LCD reads properly and replace the mounting screws. **The sensor housing must be screwed in the downward aimed conduit entry.** A conduit seal fitting filled with cement is required within 18 inches of the M1 for most applications and it is important to keep conduit connected to the M1 sealed. An unfortunate possibility of open conduit during installation is water entering and filling the M1 enclosure.

*Note: To gain access to the I/O PCB for wiring or mounting purposes, loosen the two captive thumb screws in the M1 front panel and remove the PANEL/CPU PCB assembly as far as allowed by the ribbon cable. The front panel and attached PCB may then be removed from the M1 housing leaving the I/O PCB fully exposed. To replace the front panel assembly, align the two thumb screws with their mating stand-offs and firmly hand tighten. Tighten thumbscrews with a screwdriver for applications in higher vibration areas.*

#### 2.2 ELECTRICAL CONNECTIONS:

See the above note for instructions how to access M1 I/O terminals for field wiring.

The M1 is a 3-wire transmitter. There is a positive 24VDC power wire (12VDC power is selected by adding solder in jumper option JO4), a positive 4-20 milliamp output signal wire and a system common wire serving as power supply and signal returns. These connect to the three point terminal block labeled TB2. An earth ground lug inside the enclosure is provided for earth grounding.

## MODEL M1 GAS DETECTOR

GDS Corp.

There is also a three point terminal block labeled TB1 provided for sensor wires. M1/LEL TB1 terminals are labeled R, C, and A. R is for the reference wire, C for the junction of the reference and analytical wires, and A for the analytical wire. A is the same electrical point as system common. Sensor excitation voltage may be measured across A and R. M1/EC TB1 terminals are labeled S, R, and C. S for the SENSE wire, R for the REFERENCE wire and C for the COUNTER wire.

TB1 and TB2 accept wire sizes up to 12 AWG. It is suggested the wires be stripped 1/4 inch and tinned with solder to prevent shorting of loose strands.

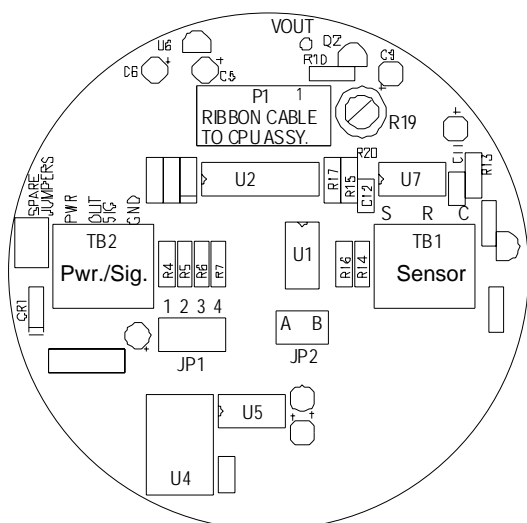

M1/EC I/O PCB FOR  
ELECTROCHEMICAL SENSORS

**FIGURE 2.1**

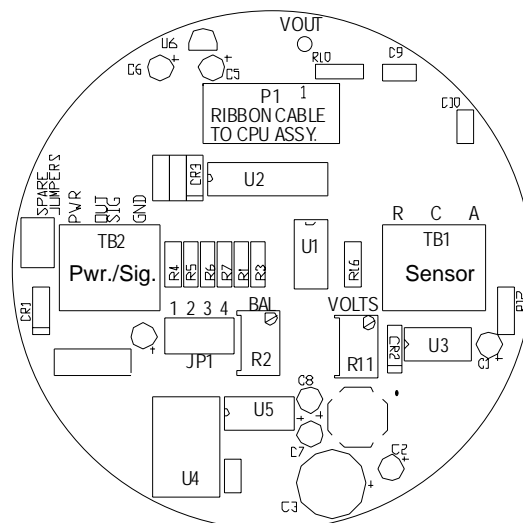

M1/LEL I/O PCB FOR  
CATALYTIC BEAD SENSORS

**FIGURE 2.2**

### SECTION III

#### OPERATING PROCEDURES

##### 3.1 'NORMAL MODE' OPERATION:

Note: After initial installation or after replacing an old sensor, procedures in sections 4.2 (LEL sensor) or 5.2 (electrochemical sensor) should be completed.

The NORMAL MODE is present any time the LCD's left arrow is not illuminated. During NORMAL MODE the M1 functions as a 4-20mA transmitter



## **MODEL M1 GAS DETECTOR**

*GDS Corp.*

with a digital LCD readout. LCD readouts are configured to display engineering units monitored by the sensor.

During NORMAL MODE the 4-20mA output and LCD readout do not track negative values between 0% and -10% of full-scale. Below -10% the FAULT alarm is tripped. This prevents erroneous negative values from being transmitted and displayed. This feature requires NORMAL MODE be exited and CAL MODE entered when checking ZERO drift. **Negative ZERO drift is only displayed during CAL MODE.**

### **3.2 OVER-RANGE:**

The sensor signal is converted to a .4 - 2 volt signal on the I/O PCB and applied to a 10 bit analog to digital (A-D) converter on the CPU PCB. If gain settings are too high on the I/O PCB (see sections 4.2.3 for LEL's or 5.2.3 for EC's), or if gas values are too high, it is possible for upscale inputs to exceed 2 volts. The A-D converter saturates at readings above 103% of full-scale, or, about 2.06 volts. This causes an OVERRANGE indication by overwriting the LCD reading with three horizontal dashes (- - -) and a rapid flashing of the left arrow. If OVERRANGE occurs during a SPAN calibration it should be halted since the analog voltage being applied to the A-D converter is too high. Either the SPAN gas is incorrect, or, the FIXED GAIN jumper setting on the I/O PCB is too high for the monitored gas (see sections 4.2.3 for M1/LEL or 5.2.3 for the M1/EC).

### **3.3 ROUTINE CALIBRATIONS USING 'CAL MODE':**

Routine calibrations of gas readings are easily performed using the magnet tool provided with each M1 Gas Detector. Enter CAL MODE by briefly holding the magnet over the CAL key until **CAL** appears on the LCD. The LCD's left arrow illuminates and the 4-20mA output holds at 1.5mA to prevent alarm trips and indicate CAL MODE. Expose the sensor to ZERO gas and observe the LCD readout. Hold the magnet over the UP ZERO or DOWN ZERO keys and adjust the reading to the correct ZERO value. Next, expose the sensor to an appropriate SPAN gas. 50% of the full scale range is suggested for SPAN gases. With the left arrow still on, hold the magnet over the UP SPAN or DOWN SPAN keys and adjust the reading to the correct SPAN value. The M1 monitor is now calibrated. Touching the CAL key again exits CAL MODE and returns to NORMAL MODE

after a 1-minute delay (see section 3.5). The CAL MODE will terminate automatically after 5 minutes of inactivity.

**3.3.1 READING SENSOR ZERO / SPAN SETTINGS ON THE LCD:**

ZERO and SPAN values applied during CAL MODE may be viewed on the LCD. After exiting the CAL MODE the UP SPAN key causes the LCD to indicate, in percent of full-scale, the amount of ZERO offset applied. The DOWN SPAN key indicates the amount of gain applied ranging between .5 and 2. Since sensor sensitivity deteriorates with age it is useful knowing how much gain has been applied over the lifetime of sensor.

**3.4 UNITY GAIN MODE:**

A UNITY key, active during CAL MODE, allows ZERO and SPAN adjustments to be centered within their range. Identified as the UNITY GAIN MODE, this is similar to setting a potentiometer's wiper exactly halfway between its clockwise and counterclockwise terminals. In UNITY GAIN the ZERO keys have a  $\pm 15\%$  of full-scale adjustment range. For example, if the sensor's ZERO output has drifted so high it reads 15% with ZERO gas applied, the DOWN ZERO key could still bring the M1 reading to ZERO but it will be at the end of its adjustment range. If the ZERO adjustment required is greater than  $\pm 10\%$  of full scale, a BALANCE adjustment should be performed as described in section 4.2.2.

In UNITY GAIN the UP / DOWN SPAN keys have a gain adjustment range of .5 to 2. For example, if sensor output sensitivity is reduced such that 50% SPAN gas provides only a 25% reading, the UP SPAN key could still calibrate the reading to the proper value of 50% but it will be at the end of its adjustment range.

**3.5 DELAY MODES:**

The POWER UP DELAY and the CAL MODE EXIT DELAY are both indicated by a slow flashing of the LCD's left arrow. The LCD readout is active but the 4-20mA output is held at 4mA during delays to prevent erroneous alarm trips.

## **MODEL M1 GAS DETECTOR**

*GDS Corp.*

### **3.5.1 POWER UP DELAY:**

The 4-20mA output is held at 4mA for 1-minute after power is applied. This allows the sensor to stabilize and reduce the possibility of causing an erroneous alarm condition within the gas detection system.

### **3.5.2 'CAL MODE' EXIT DELAY:**

SPAN values are typically the last gas applied during a routine calibration. If the CAL MODE is exited immediately after removing SPAN gas from the sensor, the reading may still correspond to the SPAN value and trip alarms. Therefore, the 4-20mA output is held at 4mA for 1-minute after exiting the CAL MODE.

### **3.5.3 AUTOMATIC 'CAL MODE' EXIT TIMER:**

The 4-20mA output is held at 1.5mA during the CAL MODE. This alerts any loop monitoring devices that a special condition is present. Since it is possible for an operator to forget to return the M1 to the NORMAL MODE, a 5-minute timer monitors the magnetic keypad during the CAL MODE. If no keystroke occurs during a 5-minute interval, the CAL MODE is exited and the 4-20mA output becomes active again.

### **3.5.4 ABORTING THE DELAY MODES:**

Trouble-shooting and other procedures may be easier without the delay periods described above. Delays may be aborted by removing power, holding the magnet over the UP ZERO key, and reapplying power. The sensor must not be in a FAULT condition when power is applied. Any subsequent power up without holding the magnet to the UP ZERO key returns the delay periods.

## **3.6 FAULT CONDITIONS:**

The FAULT / KEYPAD LED is a dual-purpose indicator. It illuminates to provide visual feedback when the magnet tool is activating a key but flashes to signal a FAULT condition. A FAULT also causes the 4-20mA output to be held at 0mA. Negative sensor drift below -10% of full scale automatically causes a FAULT indication. Sensor failures, as described in sections 4 & 5, also cause the FAULT indication.

**3.7 LCD METER SPAN SETUP MODE:**

The 3½ digit LCD meter span and decimal points may be configured for full scale ranges such as 0-100, 0-25.0, 0-10.0, 0-1000 and many others. Zero percent of full-scale readings, or those corresponding to 4mA, are always assumed to equal a reading of 0. Holding the magnet over the CAL key for at least 5 seconds enters the LCD METER SPAN SETUP MODE. The current setting for 100% full-scale is displayed and may be modified using the UP/DOWN SPAN keys. This sets the LCD reading displayed when the 4-20mA output equals 20mA. Decimal points may be added using the UNITY key.

**3.8 4-20MA SOURCE MODE:**

This feature is provided to make it easier to test display and alarm devices connected to the M1's 4-20mA output without exposing the sensor to test gas. During NORMAL MODE operation, holding the magnet over the DOWN ZERO key for at least 10 seconds places the unit into a 4-20mA SOURCE MODE. The LCD indicates directly in milliamps the actual value of the 4-20mA output regardless of gas on the sensor. The UP / DOWN SPAN keys are used to set this value between 4mA and 20mA. 4-20mA SOURCE MODE exits back to NORMAL MODE by touching the UNITY key, or automatically after 5 minutes without operator input.

**3.9 "END OF SENSOR LIFE" INDICATION**

Old sensors near the end of their service life require higher gain settings. The M1 "END OF SENSOR LIFE" (ESL) feature may be used to indicate this condition. A span trip point may be entered that when exceeded causes the LCD to flash an ESL reading for 2-seconds each 10 seconds. Holding the magnet to the UNITY key for at least 5 seconds brings to the LCD a span value set-point reading for setting when the ESL indication trips. CAL MODE GAIN adjustments range between .5 and 2 and the ESL set-point is adjustable between 1.5 and 2.01 with 2.01 turning the ESL feature off. The current span setting may be viewed on the LCD during NORMAL MODE by touching the DOWN SPAN key.

## **MODEL M1 GAS DETECTOR**

GDS Corp.

### **SECTION IV**

#### **MODEL M1 LEL CATALYTIC BEAD SENSORS**

##### **4.1 GENERAL DESCRIPTION:**

The M1 system including optional items and part numbers is shown in Figure 4.3. Catalytic bead combustible sensors consist of an analytical and reference element. The analytical element is coated with a catalyst causing it to react with combustible gas compounds, raising its temperature and therefore its resistance. The reference element remains stable in the presence of these gases. Sensors interfaced to the M1/LEL are powered by a high efficiency switching power supply with an adjustable output. An input bridge circuit and balance adjustment allows matching each combustible sensor to the M1/LEL input.

##### **4.1.1 SENSOR POISONING:**

It is important to understand that all catalytic sensors may be poisoned causing loss of sensitivity. Silicon, sulfur and lead containing compounds are especially detrimental. Although GDS Corp. sensors have special poison resistant qualities; all combustible gas detectors operating in these environments should be calibrated more frequently and especially following exposure to a poisoning substance.

Please see ISA publication RP12.13 Part II-1987 ([www.isa.org](http://www.isa.org)) for additional information concerning recommended operating procedures for these detectors.

##### **4.2 M1/LEL INITIAL START-UP AND CALIBRATION PROCEDURE:**

***Note:*** *Units shipped from GDS Corp. with the sensor installed have had adjustments described in sections 4.2 and 4.3 already performed at the factory! This information is provided to assist users replacing defective sensors; installing M1/LEL detectors with remotely mounted sensors, or changing the calibration to another combustible compound. The front panel assembly must be removed as described in section 2.1 to access potentiometers and perform these adjustments.*

**IMPORTANT:** Be sure to classify the area as non-hazardous prior to opening the M1 or any other electronic enclosures.

**4.2.1 SENSOR VOLTAGE ADJUSTMENT (INITIAL CALIBRATIONS):**

The sensor voltage adjustment, using SENSOR VOLTAGE ADJUST potentiometer R11 on the I/O PCB (see FIGURE 4.2), is done upon initial installation of the catalytic bead sensor to the M1/LEL monitor. Most applications have the Universal Sensor head mounted directly to the M1 housing. In these cases the 2-volt sensor voltage across the A & R terminals is preset at the factory. Applications utilizing the 10-0193 Remote Sensor Housing must, upon initial installation only, adjust R11 for 2-volts AT THE SENSOR. High currents flowing through long wires cause voltage losses across the wires. To compensate for the loss it is necessary to set the voltage at the M1 A & R terminals higher than the desired 2-volt sensor voltage. It is then recommended the R11 potentiometer screw be covered with a small dollop of RTV or epoxy to prevent accidental over-voltage conditions at the sensor.

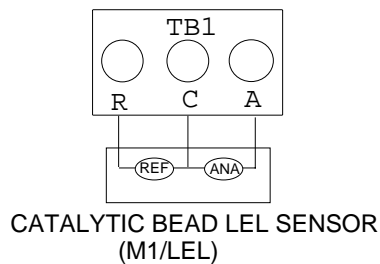

**FIGURE 4.1**

**4.2.2 MONITORING VOUT TEST POINT (INITIAL CALIBRATIONS):**

The VOUT test point on the I/O PCB may be monitored during the remainder of this section to verify correct initial set-up. An alternative is to attach the LCD assembly ribbon cable and monitor VOUT using the M1's LCD. The LCD assembly must be placed in UNITY GAIN (see section 3.4).

To use a voltmeter, the minus lead is attached to the power supply return, or 0 volt terminal, and the plus lead to the VOUT test point. The active range of VOUT is .4 - 2 volts, corresponding to 0-100% of full scale. Therefore, 0% = .4 volts, 25% = .8 volts, 50% = 1.2 volts, 75% = 1.6 volts and 100% = 2.0 volts. The I/O board may be considered properly configured when VOUT or the LCD is within 20% of the desired span reading. For example, if 50% of LEL SPAN gas

## MODEL M1 GAS DETECTOR

GDS Corp.

reads between 9 and 1.5 volts, this is an acceptable value if 100% of LEL is full-scale.

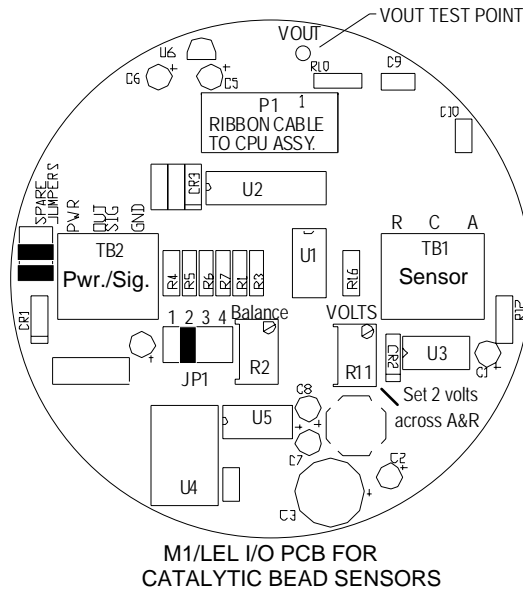

**FIGURE 4.2**

### **4.2.3 BALANCE ADJUSTMENT (INITIAL CALIBRATIONS):**

Differences from sensor to sensor require a BALANCE adjustment that matches a new sensor to the M1/LEL bridge circuit. This adjustment need only be made once with a new sensor and is preset at the factory for units shipped with the sensor installed. With the new sensor exposed to a ZERO gas (usually ambient air) adjust BALANCE potentiometer R2 until the VOUT test point equals .4 volts (or 0 on LCD with CAL and UNITY modes invoked). THIS IS AN APPROXIMATE ADJUSTMENT. THE FINAL PRECISION ADJUSTMENT IS MADE VIA THE MAGNETIC ZERO CONTROLS. The UP/DOWN ZERO magnetic controls have a  $\pm 15\%$  of full-scale adjustment range that the sensors' ZERO drift must exceed before requiring another BALANCE adjustment.

### **4.2.4 M1/LEL FIXED GAIN ADJUSTMENT (INITIAL CALIBRATIONS):**

The M1 I/O PCB has 4 fixed ranges of sensitivity, selectable via JP1 and labeled 1, 2, 3 & 4. The VOUT test point has a range of .4 - 2 volts for 0 - 100% of the measurement range. The BALANCE potentiometer sets the .4 volt value with

## MODEL M1 GAS DETECTOR

*GDS Corp.*

ZERO gas applied as described in section 4.2.2. JP1 sets the coarse upscale SPAN value by setting the gain of the bridge circuit. JP1 is set correctly if 50% of full-scale span gas reads between .9 & 1.5 volts at VOUT. Fine-tuning of these settings is done later by adjusting the M1 magnetic controls. JP1 jumpers require reconfiguring only if a new sensor is installed or if the monitoring range is changed.

JP1 gain values are as follows:

JP1, position 1 = GAIN = 51

JP1, position 2 = GAIN = 26

JP1, position 3 = GAIN = 12.5

JP1, position 4 = GAIN = 7

More than one jumper may be installed to allow additional gain values. Multiple jumpers are additive in relation to the gain value. For example, if a gain of 20 is needed, jumpers may be placed in positions 3 and 4 to provide a gain of 19.5.

When using the LCD to read the output and configure JP1 it is important to place the M1 in CAL MODE & UNITY GAIN MODE (see section 3.4) to insure additional gain and offset is not being applied by the magnetic controls.

### **4.3 LEL SENSOR FAULT SUPERVISION:**

The typical failure mode of catalytic bead sensors is the reference or active beads open circuit. In rare cases a short circuit may develop. The M1/LEL is equipped with fault detection circuitry that detects either condition. A FAULT is also indicated if the output drifts below-10% of full scale. The M1/LEL signals a FAULT condition exists by overwriting the LCD with a **FLt** message, flashing the red LED on the front panel and clamping the 4-20mA output at 0mA. These conditions remain until the FAULT is corrected.

### **4.4 SENSOR REPLACEMENT:**

**IMPORTANT: Be sure to reclassify the area non-hazardous before opening the M1 or any other electronic enclosures.**



## **MODEL M1 GAS DETECTOR**

*GDS Corp.*

The GDS Corp. Universal Sensor head allows replacement of defective and worn out sensor elements; significantly lowering its cost compared to “throwaway” heads. Return the head to GDS Corp. for replacement or trained personnel in the field, using the 10-0187 tool kit, may remove the retaining nut and plug in a new sensor module. Figure 4.3 illustrates this procedure.

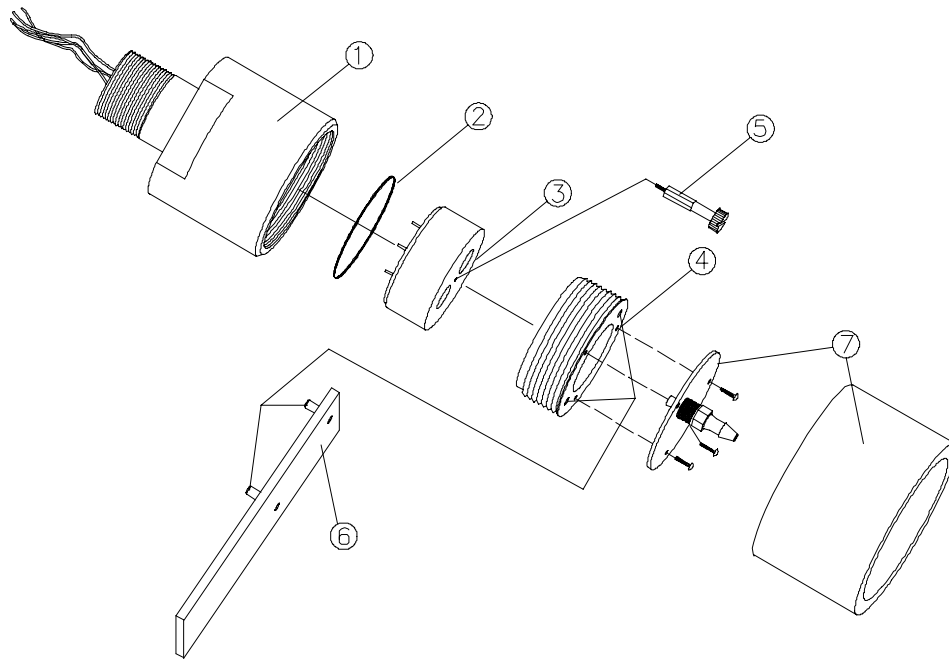
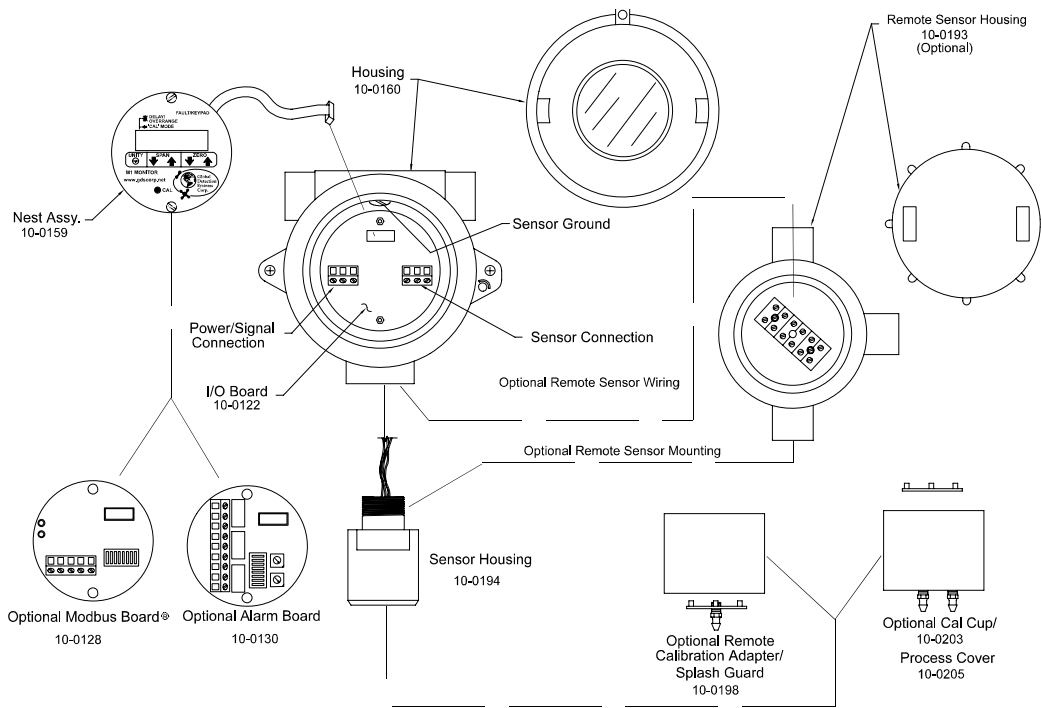

**FIGURE 4.3**

1. Universal Sensor Head Gland (# 10-0200)
2. “O” ring (# 1000-1937)
3. LEL Sensor Module (# 10-0199). Consult factory for electrochemical sensors.
4. Sensor Head Retainer Nut with Flame Arrestor (# 10-0201)
- 5, 6. Sensor Installation Tool Kit Option (10-0187)
7. Splash Guard with Remote Calibration Adaptor Option (10-0198)

Items 1 – 4 are components of the Universal Sensor Head. Items 5 & 6 compose the 10-0187 *Sensor Replacement Tool Kit* option.

Figure 4.4 illustrates the M1 Monitor system assembly and available options.



**FIGURE 4.4**

**SECTION V**

**MODEL M1/EC FOR ELECTROCHEMICAL SENSORS**

**5.1 GENERAL DESCRIPTION:**

The Model M1/EC accepts electrochemical sensors directly, without need of other transmitters or electronics. The microamp output from the sensor is converted to .4-2 volt by a pre-amplifier on the M1/EC I/O PCB (Figure 5.2). There is a three point terminal block labeled TB1 provided for sensor wiring. TB1 has **SENSE**, **REFERENCE**, and **COUNTER** terminals that connect directly to corresponding sensor terminals as illustrated in Figure 5.1.

# MODEL M1 GAS DETECTOR

GDS Corp.

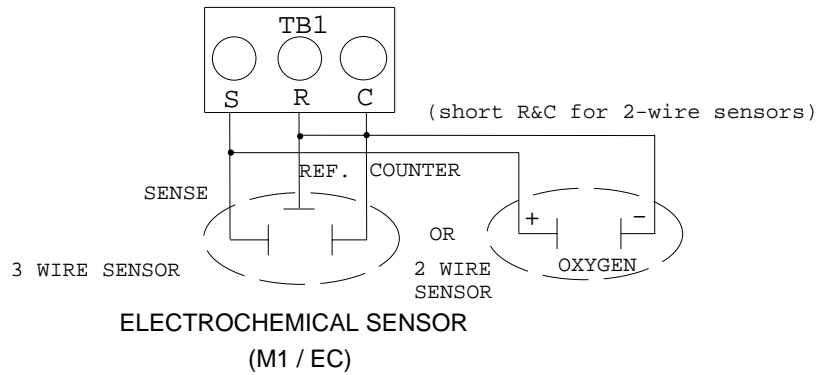

**FIGURE 5.1**

## 5.2 M1/EC INITIAL START-UP AND CALIBRATION PROCEDURE:

**Note:** Units shipped from GDS Corp. with the sensor installed have had adjustments described in sections 4.2 and 4.3 already performed at the factory! This information is provided to assist users replacing defective sensors or changing calibration to another range. The front panel assembly must be removed as described in section 2.1 to access jumpers.

**IMPORTANT:** Be sure to reclassify the area non-hazardous before opening the M1 or any other electronic enclosures.

### 5.2.1 SENSOR RESPONSE COEFFICIENT:

Jumper header JP2, located on the I/O PCB, allows the M1/EC to be configured to accept either positive or negative coefficient sensors. JP2s' dual jumpers must **both** be placed in either the 'A' or 'B' positions. 'A' position corresponds to positive coefficient output sensors and 'B' to a negative.

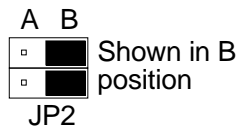

**FIGURE 5.2**

### 5.2.2 M1/EC INITIAL FIXED GAIN ADJUSTMENT:

The M1 I/O PCB has 4 fixed ranges of sensitivity selectable via JP1 labeled 1, 2, 3 & 4. The VOUT test point on the I/O PCB has a range of .4 - 2 volts for 0 - 100%

## MODEL M1 GAS DETECTOR

GDS Corp.

of the measurement range. JP1 jumpers set the coarse upscale SPAN values by affecting the gain of the analog circuit. JP1 is set correctly if 50% of full-scale gas reads between .9 & 1.5 volts on VOUT. Fine-tuning of these settings is done later by adjusting the M1 magnetic controls. JP1 jumpers normally only require configuring if a new sensor is installed or if the monitoring range is changed. JP1 gain values are as follows:

JP1, position 1 = GAIN = 5.5

JP1, position 2 = GAIN = 4

JP1, position 3 = GAIN = 2.3

JP1, position 4 = GAIN = 1.5

More than one jumper may be installed to allow additional gain values. Multiple jumpers are additive in relation to the gain value. For example, if a gain of 6.5 is needed, jumpers should be placed in positions 2 and 3 to provide a gain of 6.3.

The gain value required for an application is determined by applying a known value of gas and configuring JP1 for the correct voltage on the VOUT test point.

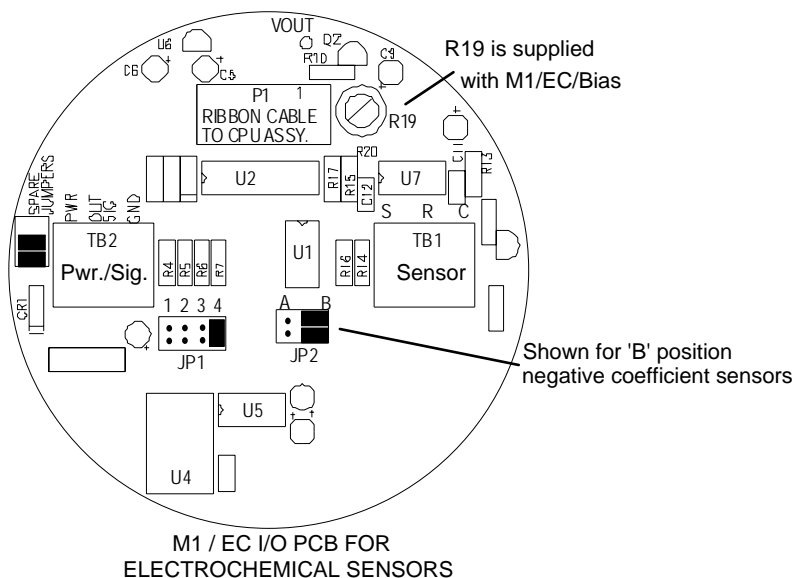

**FIGURE 5.2**

## **MODEL M1 GAS DETECTOR**

*GDS Corp.*

### **5.3 MISSING ELECTROCHEMICAL SENSOR FAULT SUPERVISION:**

Many electrochemical sensor housings allow for easy replacement of defective sensors by making the sensors 'plug in'. A problem is that if the sensor is removed some continue to display a safe 0 PPM reading. The M1/EC is equipped with fault detection circuitry that detects a missing sensor. Within several minutes of removing an EC sensor, the M1/EC will signal a FAULT condition. A FAULT is also detected if the sensor output drifts below -10% of full scale. The M1/EC demonstrates a FAULT condition exists by overwriting the LCD reading with **FLt**, illuminating the red LED on the front panel and by clamping the 4-20mA output at 0mA. These conditions exist until the FAULT is corrected.

### **5.4 M1/EC/BIAS MODEL SUPPORTS BIASED SENSOR TYPES:**

Certain specialized electrochemical sensors are designed to work with the *sensing* electrode potential above that of the *reference* electrode, otherwise known as 'biased' operation. A special model of the M1/EC is available to support this by adding a */BIAS* suffix to the model number. Additional circuitry is included on the M1/EC/BIAS I/O board. Most noticeable is potentiometer R19 used for setting the sensors' bias millivolts. Sensors requiring biased operation oftentimes require as much as 24 hours stabilization after power is applied.

### **5.5 SENSOR REPLACEMENT:**

See section 4.5.

## **SECTION VI**

### **OPTIONAL FEATURES**

#### **6.1 OPTIONS GENERAL DESCRIPTION:**

Space is provided behind the front panel/CPU assembly to add a single circuit board for adding features not provided on the standard M1. Field wiring should be an important consideration when determining if an option is required. Each option board contains terminals for wiring that are located behind the front panel /

CPU assembly. Space for field wiring inside the M1 enclosure is limited and care must be taken to cut wires to only the length needed to complete connections.

**6.2 ISOLATED 4-20 MILLIAMP OUTPUT OPTION:**

The 10-0127 Isolated 4-20mA output option is shown in Figure 6.1. TB1 provides the 1500 V isolated 4-20mA output signal. This option should be used when it is necessary the 4-20mA output be isolated from the M1 power supply and sensor inputs.

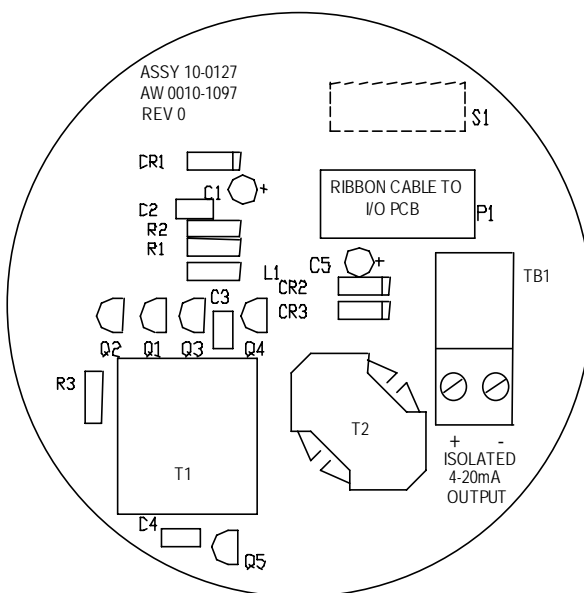

**FIGURE 6.2 / 10-0127 OPTIONAL ISOLATED 4-20mA OUTPUT PCB**

**6.3 MODBUS® RS-485 SERIAL INTERFACE OPTION:**

The 10-0128 Modbus RS-485 serial interface option allows up to 128 M1 Transmitters to communicate to a Modbus master device on a single cable. Modbus is the *protocol*, or language used by the M1 to communicate with other devices. The M1 is a Modbus *slave*, requiring a Modbus *master* to interrogate it and retrieve information made available in specific register locations. The RS-485 electrical standard allows cable lengths up to 4000 feet between Modbus master and slave. Both 4-wire full duplex and 2-wire half duplex connections are supported by the M1 serial interface option. Recommended cables are Belden part # 9841 for 2-wire and # 9842 for 4-wire. Technical papers offering valuable

## MODEL M1 GAS DETECTOR

GDS Corp.

information concerning RS-485 networks are available at our website at [www.gdscorp.net](http://www.gdscorp.net).

The GDS Corp. C1 Controller is a typical Modbus master device capable of retrieving monitored data from the M1. Since the C1 is often connected as a Modbus *master* to a network of as many as 16 M1's the correct C1 controller Modbus menu information is provided. Configure the C1 controller channel the M1 is to provide input data to as follows: **Data From** menu = **Modbus 10bit**, **Min RAW** = **00200**, **MAX RAW** = **01000**, **Remote ID** = [must match RTU address of M1; typically 1-16], **Alias** = **33001**. The C1 Controller only requests the 10 bit gas value from register 33001 of the M1 monitor. All alarm processing and ASCII nomenclature assigned to a channel is performed by the C1 controller.

As part of the M1 CSA Certification, it was verified that optional communication functions of this gas detection instrument while operating at maximum transaction rate do not adversely affect the gas detection operation and functions of the instrument. This CSA Certification, however, does not include or imply CSA Certification of the communications protocol or functions provided by the software of this instrument or of the communications apparatus or software connected to this instrument.

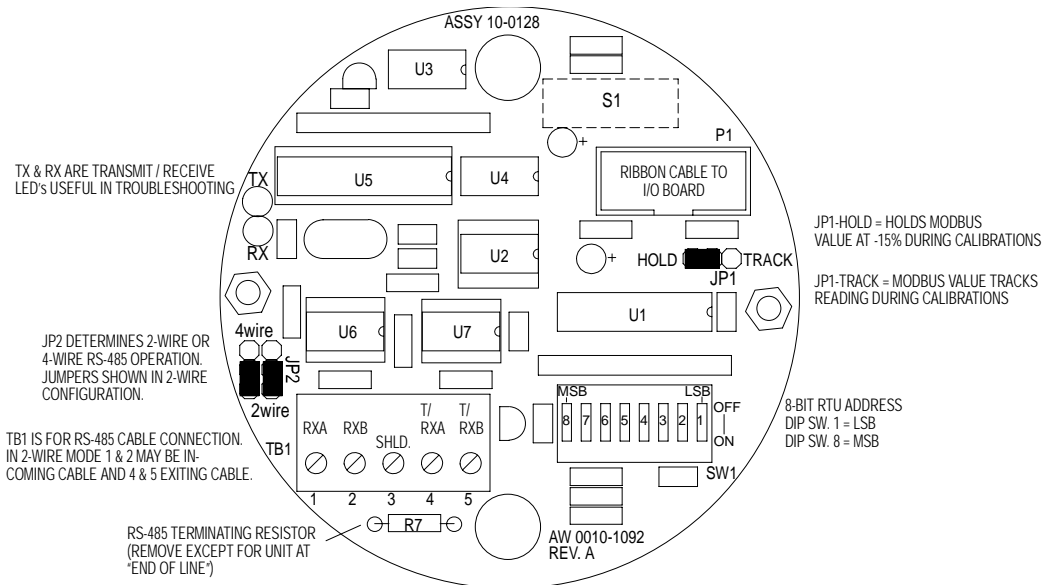

**FIGURE 6.3 / 10-0128 OPTIONAL MODBUS RS-485 PCB**

**6.3.1 RTU ADDRESSES AND TERMINATING RESISTORS:**

Up to 128 M1 10-0128 RS-485 options may be “multi-dropped” onto the same RS-485 cable. Its 8-position DIP switch allows unique RTU addresses be assigned to each M1, necessary for the modbus master to be able to address M1’s separately. The 8 DIP switches represent an 8 bit binary number with 1 = LSB and 8 = MSB. For example, OFF, ON, ON, OFF, ON, OFF, OFF, OFF = 0110 1000 = RTU address 104. A different RTU address must be assigned for each M1 communicating on the same RS-485 port. **IMPORTANT: DIP switch RTU address changes only take effect after M1 power is cycled from OFF to ON.**

M1 10-0128 options are shipped with terminating resistors (R7) installed. R7 should be removed from all except the M1 located at “end of line”. This means the cable leaves the Modbus master and goes to the 1<sup>st</sup> M1, then to the 2<sup>nd</sup>, then to the 3<sup>rd</sup> and so on until reaching the final M1. R7 should only be installed in the *final* M1.



# MODEL M1 GAS DETECTOR

GDS Corp.

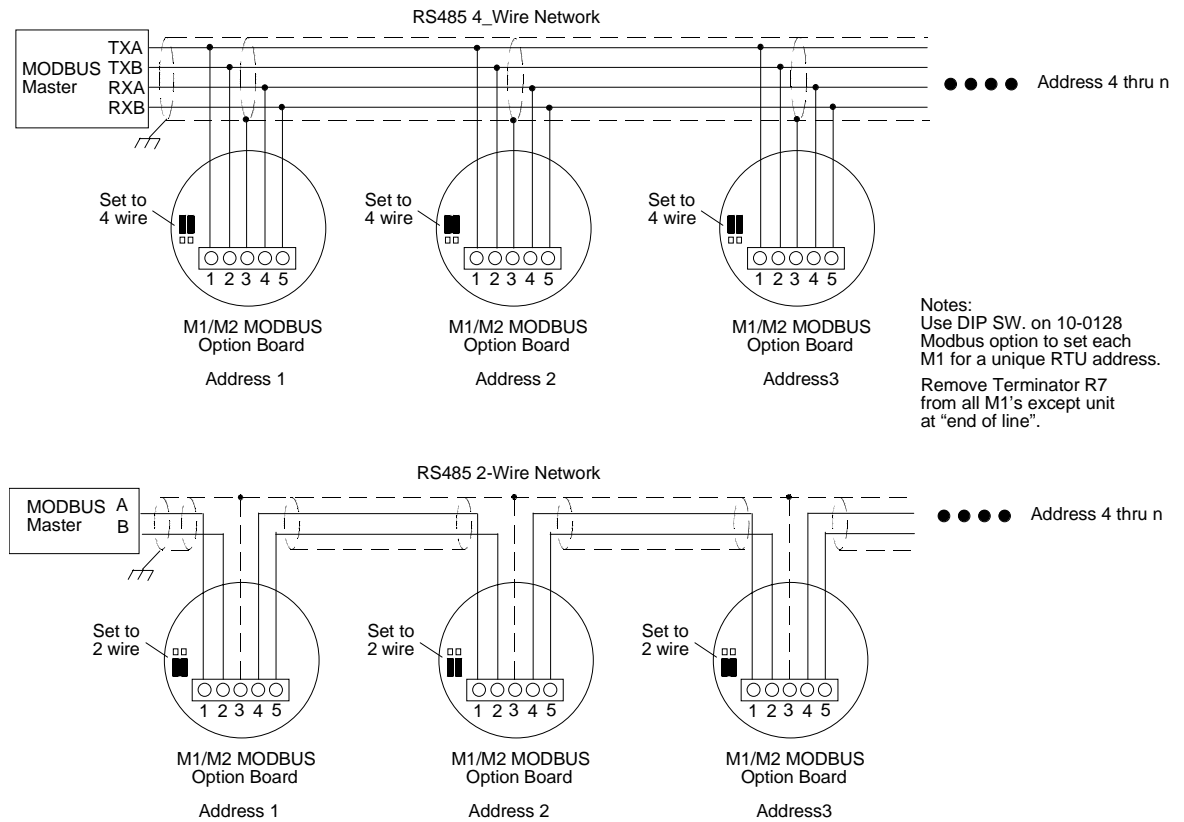

**FIGURE 6.4 / TYPICAL RS-485 NETWORK WIRING**

## 6.3.2 MODBUS DATA REGISTERS AND FUNCTION CODES:

The following table identifies M1 Modbus register locations and function codes:

### MODBUS REGISTER SUMMARY

| VARIABLE         | ALIAS        | READ FUNCTION CODE | WRITE FUNCTION CODE |
|------------------|--------------|--------------------|---------------------|
| <b>FAULT BIT</b> | <b>12000</b> | <b>2</b>           | <b>NA</b>           |

0 = OK

1 = Fault

|               |              |          |           |
|---------------|--------------|----------|-----------|
| <b>ALARMS</b> | <b>12008</b> | <b>2</b> | <b>NA</b> |
|---------------|--------------|----------|-----------|

Returned as 8 discrete bits packed in the low byte of the response data.

12008:bit 0 = Fault (tracks 12000)

12008:bit 1 = Alarm1

12008:bit 2 = Alarm2

12008:bit 3 = Not Used

12008:bit 4 = Not Used

12008:bit 5 = Not Used

# MODEL M1 GAS DETECTOR

GDS Corp.

12008:bit 6 = Alarm2 Acknowledgeable

12008:bit 7 = Not Used

**A2D Raw**                      **33000**                      **3&4**                      **NA**

10 bit value representing the A2D value of 0 to 1023 for -20 to 103 %FS (197=0% & 1003=100%).

**A2D ASCII**                      **31010 (6 bytes)**                      **3&4**                      **NA**

6 bytes of data representing the scaled span value including the decimal point. The first 5 bytes contain the value with the last byte being a space. They are arranged with the first byte as the MSD with leading zero spacing. For example, with a span value of 1234 with 1 decimal point, the correct value of 123.4 is returned for 100% of full scale as follows:

|            |           |      |      |      |      |      |      |      |      |        |        |
|------------|-----------|------|------|------|------|------|------|------|------|--------|--------|
| Byte       | 0         | 1    | 2    | 3    | 4    | 5    | 6    | 7    | 8    | 9      | 10     |
| Response   | [address] | [04] | [06] | [31] | [32] | [33] | [2E] | [34] | [20] | [Crcl] | [Crch] |
| ASCII Char | [address] | [♦]  | [♠]  | [1]  | [2]  | [3]  | [.]  | [4]  | [sp] | [Crcl] | [Crch] |

With the same settings a 50% of full-scale reading of 617 would be:

|            |           |      |      |      |      |      |      |      |      |        |        |
|------------|-----------|------|------|------|------|------|------|------|------|--------|--------|
| Byte       | 0         | 1    | 2    | 3    | 4    | 5    | 6    | 7    | 8    | 9      | 10     |
| Response   | [address] | [04] | [06] | [20] | [36] | [31] | [2E] | [37] | [20] | [Crcl] | [Crch] |
| ASCII Char | [address] | [♦]  | [♠]  | [sp] | [6]  | [1]  | [.]  | [7]  | [sp] | [Crcl] | [Crch] |

**EUNITS**                      **40319-40324**                      **3**                      **6**

6 ASCII characters assigned to the engineering units read as bytes.

**Measurement Name**      **40325-40340**                      **3**                      **6**

16 ASCII characters assigned to the unit identifier read as bytes.

**Span**                      **40343**                      **3**                      **6**

An integer from 1 to 9999 used to scale the A2D ASCII value.

**Alm1Setpoint**              **40345**                      **3**                      **6**

**Alm2Setpoint**              **40347**                      **3**                      **6**

Integer compared to the A2D Raw value to determine alarm 1 or 2 status. The 0 to 100% set point must be scaled from 197 to 1003. This is done by using  $(Alarm\% * 806) + Offset$ .

Example: A 40% set point would be computed as  $(.4 * 806) + 197$

**D.P.Position**              **40349**                      **3**                      **6**

Determines how many decimal positions return with the A2D ASCII value. Valid range is 0 to 3.

**Alm1Trip**                      **40351**                      **3**                      **6**

**Alm2Trip**                      **40359**                      **3**                      **6**

Set to 255 alarms on high, set to 0 alarm on low.

**Alm1Latch**                      **40353**                      **3**                      **6**

**Alm2Latch**                      **40355**                      **3**                      **6**

Set to 0 causes alarm 1 or 2 to auto reset, set to 255 causes alarms 1 or 2 to latch.

**AlmZoneWord**              **40357**                      **3**                      **6**



*contacts. Arcing generates high levels of RFI that interfere with measurements.*

The 10-0139 Alarm option provides 5-amp resistive form C relays for ALARM 1, ALARM 2 and ALARM 3 conditions. ALARM 3 is typically a *fail-safe* FAULT relay and is activated by the defective sensor conditions described in sections 4.3 and 5.3 of this manual. Since it is fail-safe, it also indicates loss of power conditions at the M1. If the FAULT relay is not needed it is possible to configure the ALARM 3 relay to trip at the ALARM 2 trip point. This is useful if ALARM 2 is to drive an audible device that needs to be *acknowledgeable* and another ALARM 2 relay is needed for driving a *non-acknowledgeable* device such as a strobe light.

ALARM 1 and ALARM 2 trip points are controlled by 16 position rotary DIP switches. See Figure 6.4 for a definition of switch functions for the alarm option PCB. Both alarm trip points incorporate approximately 1.5% dead-band. Therefore, the signal must drop about 1.5% below the trip level to reset the alarm. This prevents alarm “chatter” when the input signal equals the trip level.

#### **6.4.1 LATCHING ALARMS:**

Setting the FUNCTION DIP switches for *latching* operation requires manual reset of alarm conditions. A remotely mounted reset switch may be wired to the 2-position TB4. RESET may also be accomplished locally, without opening the enclosure, by holding the magnet near the southwest angle on the M1 enclosure as shown below.

## MODEL M1 GAS DETECTOR

GDS Corp.

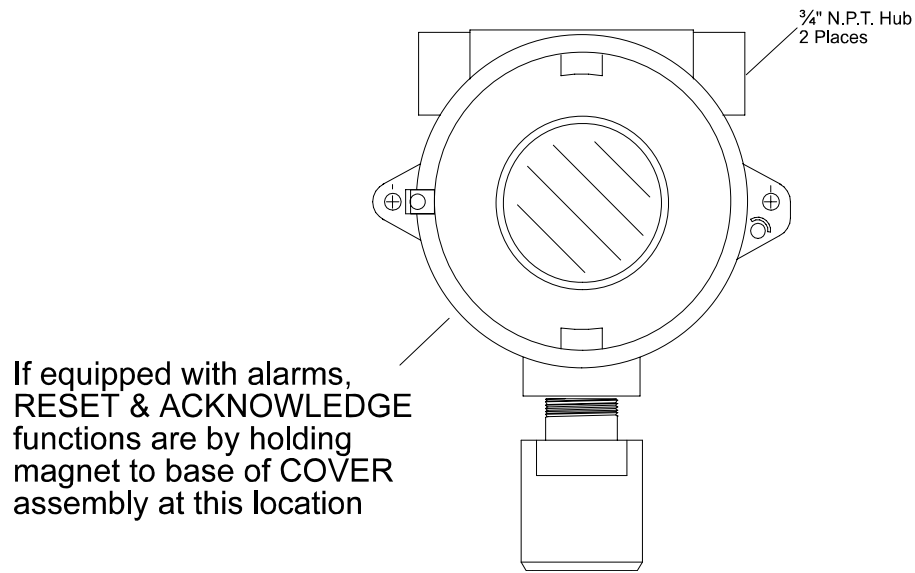

### **6.4.2 FAIL-SAFE ALARMS:**

The FUNCTION DIP switches offer the ability for HIGH and WARN relays to operate in a *fail-safe* condition. This means the relays are energized in the safe, or no alarm condition and when an alarm occurs the relay de-energizes. The advantage of this configuration is “loss of power” conditions create the same relay outputs as alarm conditions. The FAULT relay is always fail-safe.

# MODEL M1 GAS DETECTOR

GDS Corp.

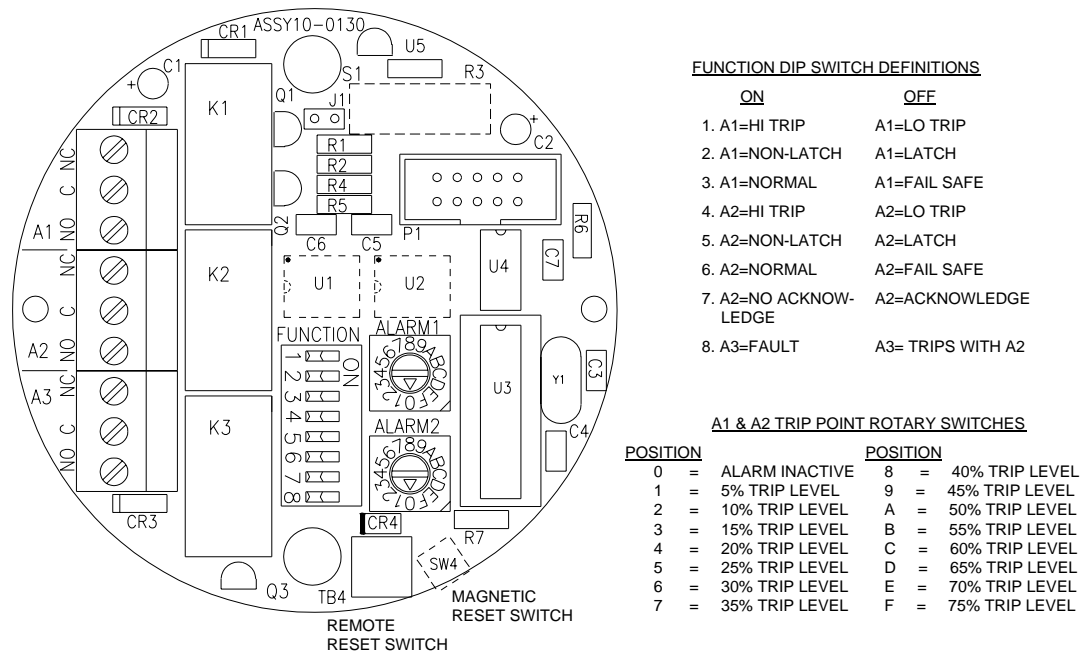

**FIGURE 6.4 / 10-0130 OPTIONAL ALARMS**

## SECTION VII

### FACTORY SERVICE AND WARRANTY

#### 7.1 FACTORY SERVICE:

When factory service is necessary, ship the instrument freight prepaid to:

GDS Corp., 2513 HWY 646, Santa Fe, TX 77510

Please include the purchase order number with which the unit was ordered.

#### 7.2 WARRANTY:

GDS Corp. warrants all equipment built by it to be free of defects and workmanship under normal use and service. If any part of the equipment described in this manual proves to be defective in workmanship or material, and if such part is returned to GDS Corp. factory within twelve months of installation, or eighteen months of the initial shipping date, it will be replaced free of charge, F.O.B. factory.

# **MODEL M1 GAS DETECTOR**

*GDS Corp.*

**GDS Corp. assumes no liability whatsoever for the use or misuse by the purchaser, his employees, or others.**

## **SECTION VIII**

### **PHYSICAL DIMENSIONS**

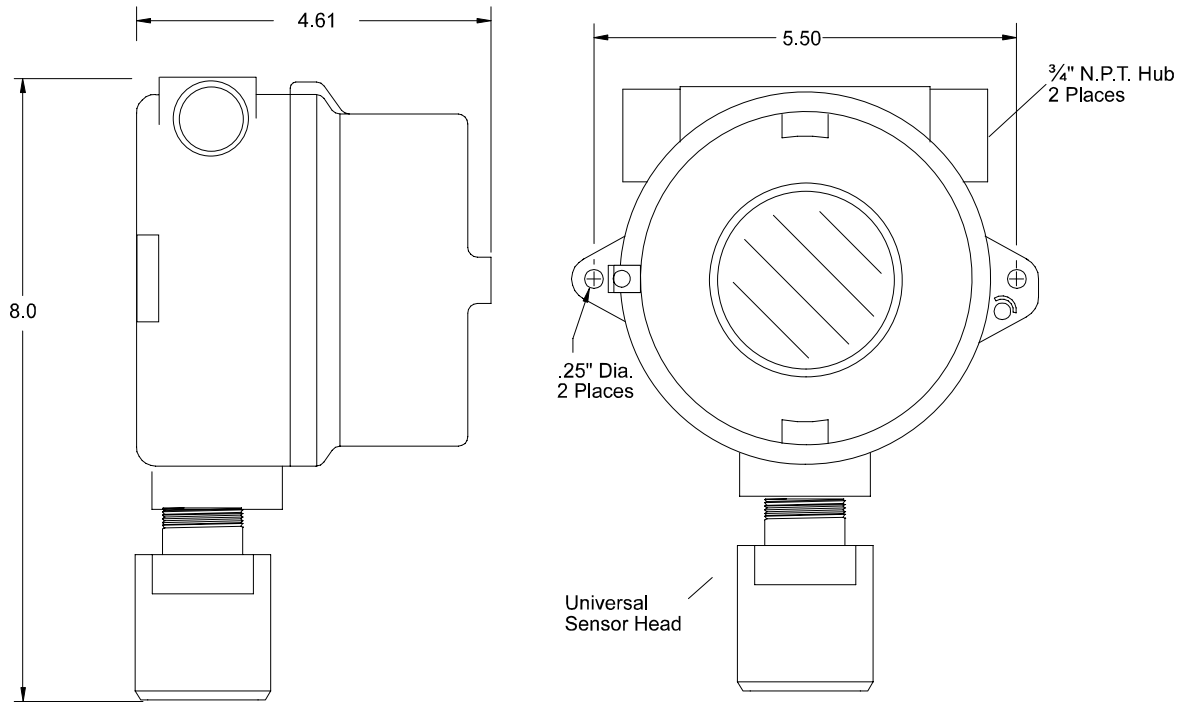

**FIGURE 8.1**