

Macurco™ Modbus RS-485 Adapter MRS-485

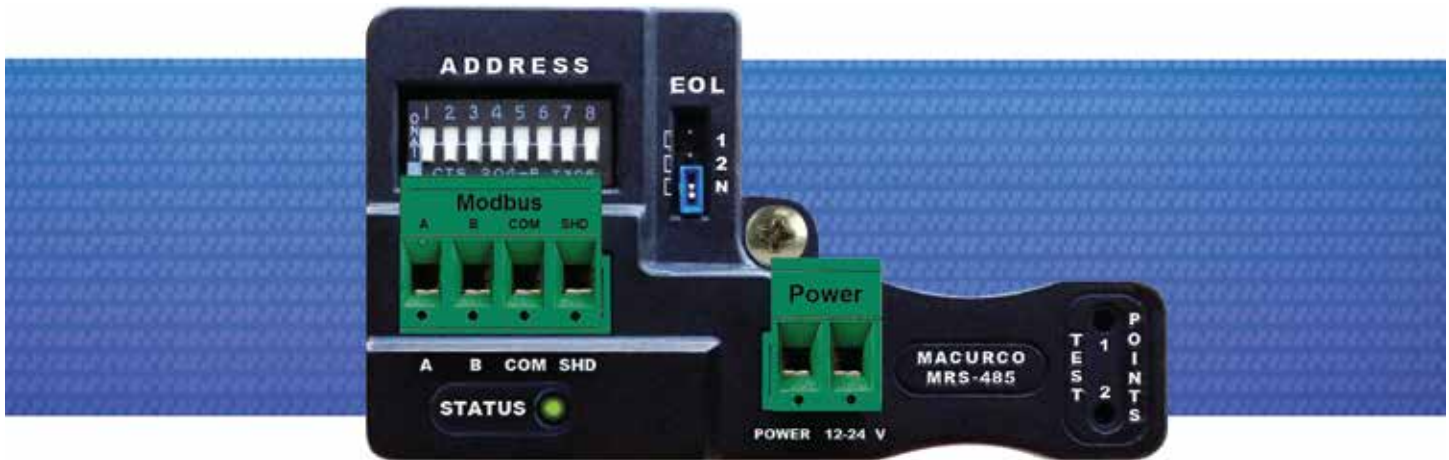

For use with Macurco 6-Series™ Detectors

Addressable Gas Detection and Control

The Macurco MRS-485 adapter is an accessory used to convert the 4-20mA analog signal from Macurco 6-Series type detectors to a digital signal for use with multipoint addressable systems. The Macurco MRS-485 simply plugs into the back of the detector and a single screw fastens it in place. The MRS-485 accepts the 4-20mA output and is powered from the same connection as the detector. The MRS-485 has the ability to interface with Building Automation Systems, Control Panels or other Control Devices that accept Modbus communications.

Features:

- The Macurco MRS-485 interfaces the detector power and 4-20mA output lines with a mounted connector
- The MRS-485 monitors sensor type, gas level and trouble status communications from any of the Macurco 6-Series detectors
- Communication is on a Modbus serial line
- Commercial type enclosure to protect and support the electronics
- Tricolor LED indicates power, test and communication status

Installation

- Mounts behind the detector inside of a standard 4" x 4" electrical box
- Held in place on the back of the 6-Series detector with a single screw
- 8 bit dip switch address selector
- RS-485 termination uses 4 pin connector with jumper to select termination:
The user selects no termination or one of the two Modbus line termination options
- Communications connections include signal (A and B), common and shield terminals
- Intended for use in non-hazardous areas such as parking garages, warehouses or other commercial facilities



MRS-485 Specifications

- Power & Current (with detector): 3.25W (max) from 12 to 24 VAC or VDC, 85mA in alarm, 60mA fan relay on and 33mA stand by @ 24 VDC
- Shipping Weight: 0.25 lb (0.11 kg)
- Size: 3 1/2 x 2 x 1 3/4 in. (8.9 X 5.1 X 4.4 cm)
- Operating Environment : 0°F to 125° F (-18°C to +52°C), 10 to 90% RH non-condensing
- Connections: plugs/terminals
- Mounting screw and screwdriver included
- MRS-485 operates in the RTU Modbus Transmission Mode
- BaudRate: 4800, 9600, 19200 (default), 38400, 57600, 115200 bps

Gas Detection

The Macurco MRS-485 Adapter converts the Macurco 6-Series 4-20mA analog output to a digital output for use with addressable network systems. The Macurco 6-Series is a family of fully programmable, low voltage, dual relay gas detectors, controllers and transducers for BAS, HVAC and Fire & Security applications. The 6-Series detectors are used to measure the concentration of various gas and provide feedback and automatic control to help ensure a safe environment: Carbon Monoxide, Methane, Propane, Hydrogen, Nitrogen Dioxide and other gases.

Connection

The Macurco MRS-485 output is connected via a four terminal screw type connector. The MRS-485 adapter is wired in the standard 2W-Modbus circuits definition with selectable built-in terminating resistors at the ends of the RS-485 bus. The power for the MRS-485 adapter is connected via a two terminal screw type connector, 12 to 24 VAC or 12 to 24 VDC and no polarity. Note: Running the Modbus cable adjacent to or in the same conduit with high voltage wires is not recommended as there may be interference from the high voltages.



6-Series Rear View



Installed MRS-485 View

TYPICAL CONNECTION OF MRS-485

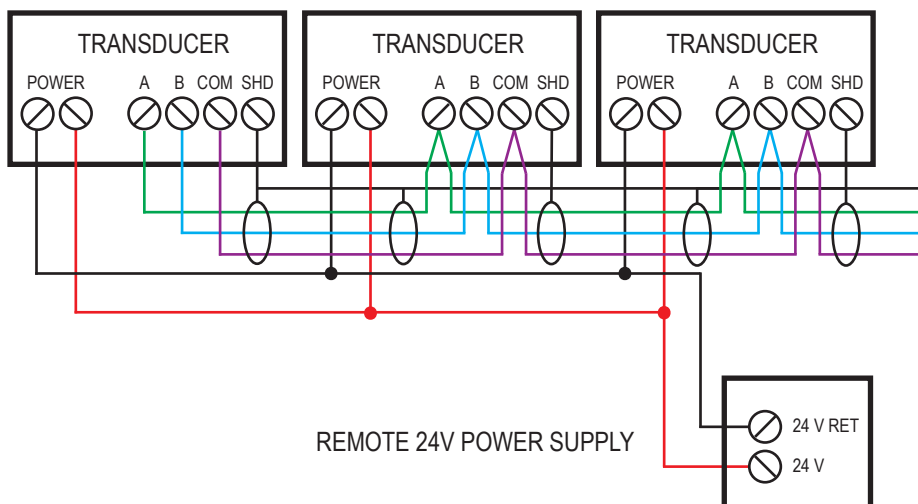

SIGNAL WIRE REQUIREMENTS

Note: It is recommended to always use twisted wires, especially for non-shielded cable, to reduce noise and allow for reliable data communication over greater distances.

Use at least 3-conductor wire with one twisted pair providing a pair for signal (A & B) and common (COM) connections.

For best performance use shielded 3-conductor wire with one twisted pair providing a pair for signal (A & B), common (COM) and shield ground (SHD) connections.

Made in the U.S.A. with US and imported materials

© Aerionics 2013. All rights reserved.
Macurco is a trademark of Aerionics, Inc.

MACURCO
Gas Detection Experts