



PolyGard® Single Point Controller SPC3-11XX

Single Point Gas Controller
Serial Number _E_1007

User Manual

May 2009

January 04, 2016 – *Revision*

PolyGard® is a registered trademark of MSR-Electronic GmbH | SPC3-11XX US



12700 Stowe Drive, Suite 100, Poway, CA 92064 | Ph: (858) 578.7887 & (888) GO.INTEC | relevantsolutions.com/intecontrols

1	Description	4
2	Operating Instruction	5
2.1	Description Keypad User Interface	5
2.2	Setting / Changing Setups or Set points	5
2.3	Code Level	6
3	Menu Overview	6
3.1	Fault Management	7
3.1.1	Acknowledge a Fault	7
3.1.2	Error Memory	7
3.1.3	System Errors	8
3.2	Stage Status	8
3.3	Relay Status	9
3.3.1	Manual Operation of the Relays	9
3.4	Menu Sensor Reading	10
3.5	Menu Relay Setups	10
3.5.1	Relay Mode	11
3.5.2	Relay Function Static / Flash	11
3.5.3	Latching Mode	11
3.5.4	Horn Function	12
3.5.5	External Relay Operation	13
3.5.6	Delay Mode of the Relay	13
3.6	Menu SP Setups	13
3.6.1	Activate – Deactivate SP	15
3.6.2	Selection Gas Type	15
3.6.3	Measuring Range	16
3.6.4	SP Signal	16
3.6.5	Stage/Set Point / Hysteresis	16
3.6.6	Delay of Alarm ON or OFF	16
3.6.7	Control Mode	17
3.6.8	SP Fault Assigned to Alarm	17
3.6.9	Alarm Assigned to Alarm Relay	17
3.6.10	SP Signal Assigned to Analog Output	17
3.7	Menu System Setups	18
3.7.1	Service Mode	19
3.7.2	Software Version	19
3.7.3	Maintenance Concept	19
3.7.4	Average Function	19
3.7.5	System Time, System Date	20
3.7.6	Customer Password (Code 1)	20
3.7.7	Analog Output	20
3.7.8	Define the Failure Relay	20
3.7.9	Power On Time	21
4	Mounting / Electrical Connection	22
4.1	Electrical Connection	22
4.2	Connection Diagram	23
4.3	Connector Block / Overview SPC3 Module	24

- 5 Commissioning..... 24**
 - 5.1 Commissioning..... 24
 - 5.2 Checklist Commissioning..... 25
- 6 Configuration and Setup Card 26**
 - 6.1 Configuration Card of System Setups..... 26
 - 6.2 Configuration Card of Alarm Relays 26
 - 6.3 Configuration Card of Measuring Setups..... 26
- 7 Specifications SPC3..... 27**
- 8 Gas Sensor..... 29**
 - 8.1 Description 29
 - 8.2 Calibration 29
 - 8.3 Zero-Point Calibration 29
 - 8.4 Gain Calibration 30
 - 8.5 Exchange of Sensor Element 30
 - 8.6 Specification Gas Sensor..... 31
- 9 Notes and General Information..... 32**
 - 9.1 Intended Product Application 32
 - 9.2 Installers` Responsibilities..... 32
 - 9.3 Maintenance..... 32
 - 9.4 Limited Warranty 32

Single Point Gas Controller SPC3-11XX

1 Description

The PolyGard® SPC3 Gas Controller is used for measuring, monitoring and warning of toxic gases. The toxic sensor (SP01) is mounted inside. One external gas transmitter (SP02) for toxic, combustible or refrigerant gases can be controlled additionally. Four alarm Stage/Set Points are free adjustable for each Sensor point(SP). Every alarm Stage/Set Point can be assigned to one of the maximum 4 alarm outputs (RX). The Gas Controller can interface via the (0)4 to 20 mA or (0)2 to 10 V output signal with any compatible electronic analog control, DDC/PLC control or automation system.

The free adjustable setups and alarm Stage/Set Point make a very flexible use in the gas measuring possible. Simple and comfortable commissioning is possible due to factory-adjusted setups.

The configuration setup settings and operation is easy to do without programming knowledge.

The PolyGard® Single Point Gas Controller SPC3 must not be used in potentially explosive atmospheres.



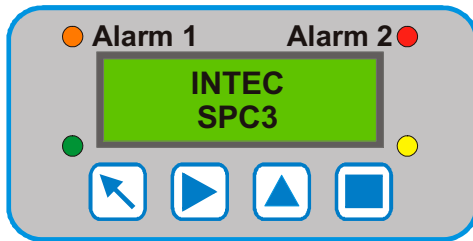

The SPC3 may only be used within ambient conditions described in the Technical Data.

2 Operating Instruction

The complete configuration, parameterization and service are made via keypad user interface in combination with the display screen. Security is provided via two password levels.



2.1 Description Keypad User Interface

-  Exit programming mode and saves settings; return to previous level or menu
-  Enter Main Menus; scrolls through Main Menus and Sub Menus; increase or decrease a value
-  Navigates through menus on the same level; moves cursor when inputing data
-  Enter Sub Menus; accepts and stores data; silence horn (if assigned)

LED orange: Flashes when alarm one or more alarms are active.
Permanently on, when one of the relays is manually operated.





LED red: Flashes when alarm two or more alarms are active.
Permanently on, when one of the relays is manually operated.

LED yellow: Flashes at system or sensor failure or when maintenance needed.

LED green: Power LED

2.2 Setting / Changing Setups or Set points

Open desired menu window.

-  Code window opens, if no code level approved.
After inputting the valid code the cursor jumps on the first position segment to be changed.
-  Push the cursor onto the position segment, which is to be changed.
-  Change the setup / set point.
-  Save the changed value. Finish.

2.3 Code Level

Code Level 1 Default Password = **(1234)** / Code Level 2 Password = **(9001)**

All changes of setups and set point values are protected by a four-digit numeric code (= password).

The code level 1 permits the operation of the SPC3; this code level is intended for the customer. The code can be changed individually via code level 2; see *section 3.7.6*.

In code level 2 all setups and set points are released; this code level is only for the service technician. *Code level 2 cannot be changed or deleted.*

The release of the code level is deleted if no button is pushed within 15 minutes.

All menu windows are visible without entering a code.

3 Menu Overview

The operation of the Single Point Gas Controller SPC3 is effected by a simple and logical menu structure that is easy to learn.

The operating menu contains the following levels:

- Starting menu.
- Main menu
- Submenu 1 and 2

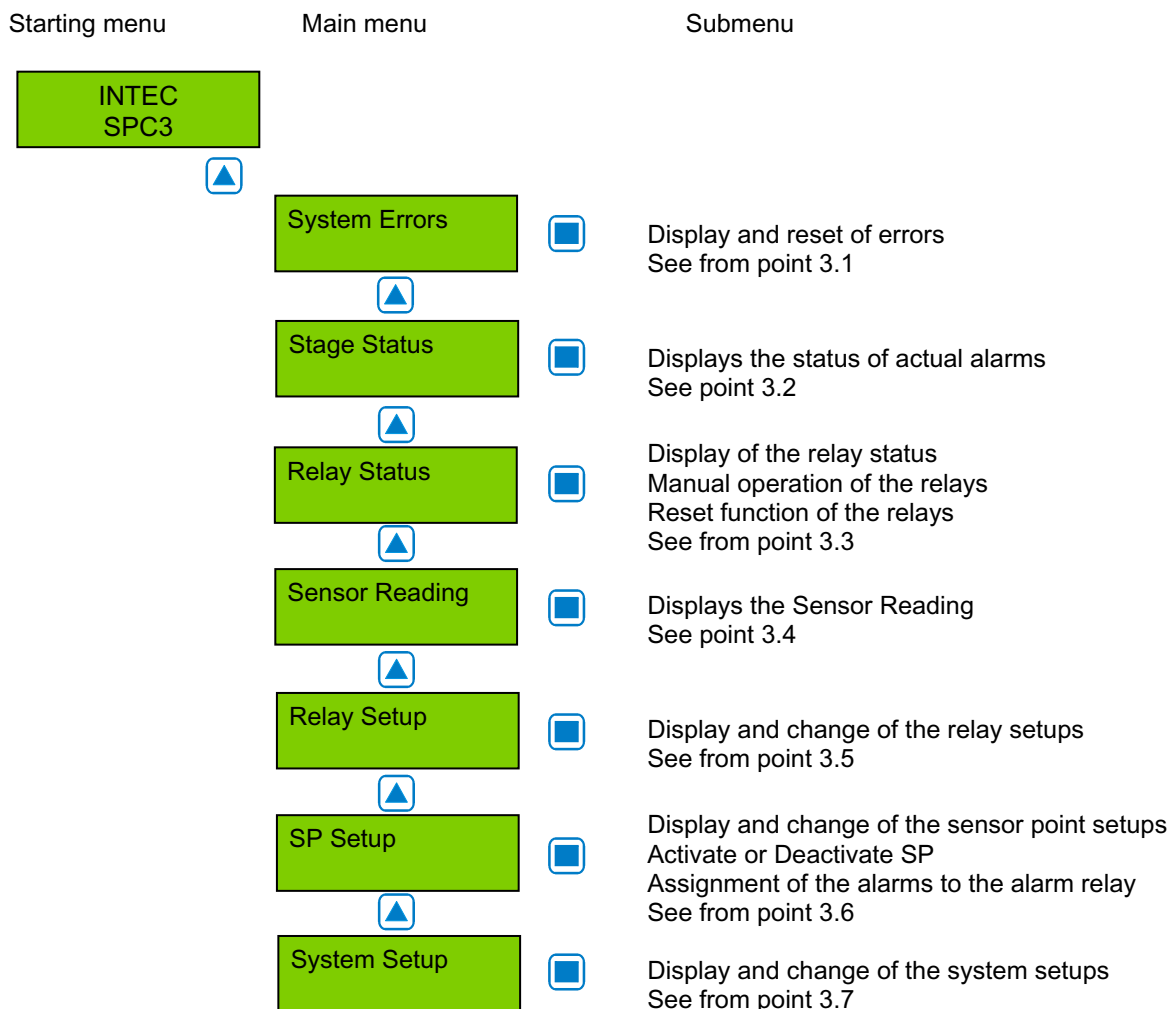

PolyGard® is a registered trademark of MSR-Electronic GmbH | SPC3-11XX US

3.1 Fault Management

The integrated fault management records the last 15 faults with date and time stamps in the menu “System Errors.” Additionally a record of the faults occurs in the “Error Memory”, which can be selected and reset only by the service technician.

An actual fault is displayed in plain text in the starting menu. The failure relay, which is defined in the system setup “Failure relay”, is activated. The yellow LED in the front of the gas controller flashes.

In case of fault of a sensor point (SP) the alarms defined in the menu “SP Setup” is activated additionally.

3.1.1 Acknowledge a Fault

Attention:

Acknowledging a fault is only possible after having removed the cause.

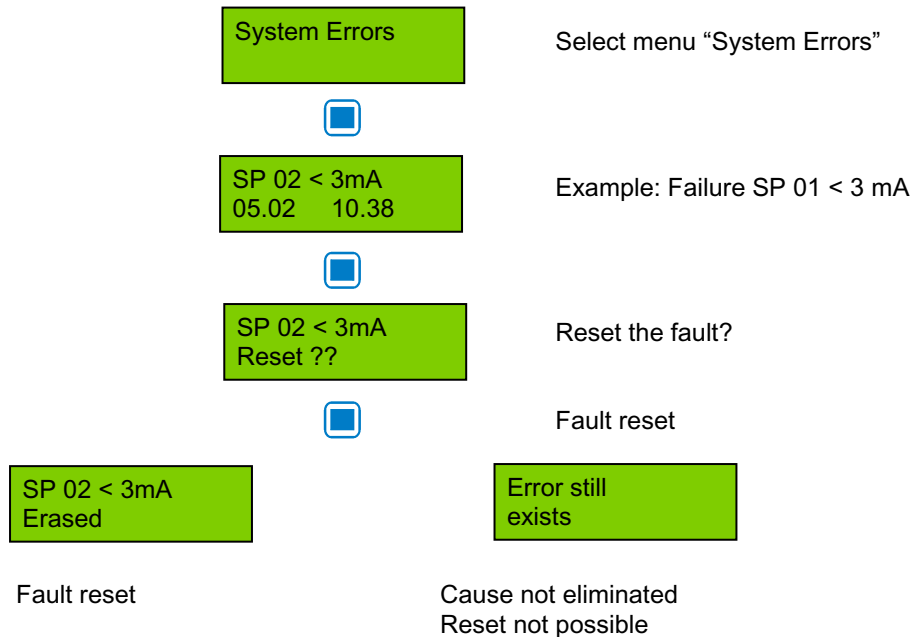

3.1.2 Error Memory

The menu “Error Memory” in the main menu “System Error” can only be opened via code level 2.

In the error memory the last 15 faults are listed for the service technician even if they were already acknowledged in the menu “System Error”. The deletion of each individual message is effected in the same way as the reset of a fault.

3.1.3 System Errors

The following system error messages are recorded:

- SP 02 > 22 mA** Current signal at analog input > 22 mA / 11 VDC. (External Transmitter)

Cause: Short-circuit at analog input or transmitter not calibrated, transmitter defective.

Solution: Check cable to transmitter, make calibration, and replace the transmitter.

- SP 02 < 3 mA** Current signal to analog input < 3 mA / 1,3 VDC. (External Transmitter)

Cause: Wire breaking at analog input or transmitter not calibrated, transmitter defective.

Solution: Check cable to transmitter, make calibration, replace the transmitter.

- GC Error:** Internal communication error I/O Board to LCD Board.

Cause: Internal error.

Solution: Change the Gas Controller module.

- Maintenance:** System maintenance is necessary.

Cause: Maintenance date exceeded.

Solution: Make the maintenance.

3.2 Stage Status

Display of the actual alarms in plain text in the order of their arrival. Only those measuring points are displayed, where at least one alarm is active. Changes are not possible in this menu.

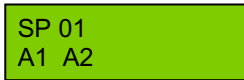

Symbol	Description	Function
SP 01	Measuring (SP) Point No.	
AX	Stage Status	A1 = Alarm 1 ON A2 = Alarm 2 ON A3 = Alarm 3 ON A4 = Alarm 4 ON

3.3 Relay Status

The SPC3 has two alarm relays (R01 / R02) and two open collector outputs (R03 / R04). In the following description they are referred to as alarm relays.

Display of the actual status of alarm relays. Manual operation of the alarm relays.



Symbol	Description	Setting Status	Function
R 01	Relay No. 01		Select Relay No.
OFF	Relay Status	OFF	OFF = Relay OFF (No gas alarm) ON = Relay ON (Gas alarm) Manual OFF = Relay manual OFF Manual ON = Relay manual ON

3.3.1 Manual Operation of the Relays

The manual operation of the alarm relays is managed in the menu "Relay Status". If a relay is in the manual ON or OFF status, the orange/ red alarm LED at the Gas Controller is lit continuously.

The external operation of the alarm relay via an assigned digital input has priority to the manual operation in the menu "Relay Status" and to gas alarm.

Relays manually operated in the menu "Relay Status" are deleted again by selecting the function "Automatic."

Acknowledging the relays in latching mode is also effected in this menu.



Select the relay

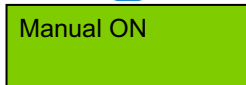

Select the function of manual operation

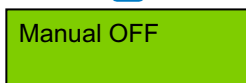

Select the function

- Manual ON = Relay ON
- Manual OFF = Relay OFF
- Automatic = Delete manual operation.
- Reset? = Reset of a latching mode.

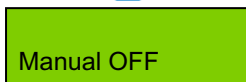

Take over the function

3.4 Menu Sensor Reading

In this menu the current value (CV) with gas unit and gas type for each active sensor point (SP) is displayed. At control mode average value (AV) is the average value additional displayed.

```
SP 01 CO ppm
50 *AV 33 CV
```

Symbol	Description	Setting Status	Function
SP 01	Measuring P. No.		Selection of SP No
CO	Gas type	CO	See 3.6.2
ppm	Gas unit		See 3.6.2
CV	Current value	CV	Current value of gas concentration
AV	Average value		Average value (10 measured values within the time unit)
*	Control mode		Display of selected control mode (CV or AV)
Not active	Status SP	Not active	SP not active
Error	Fault SP		Current signal < 3 mA or > 22 mA

3.5 Menu Relay Setups

Display and change of the setups for each alarm relay

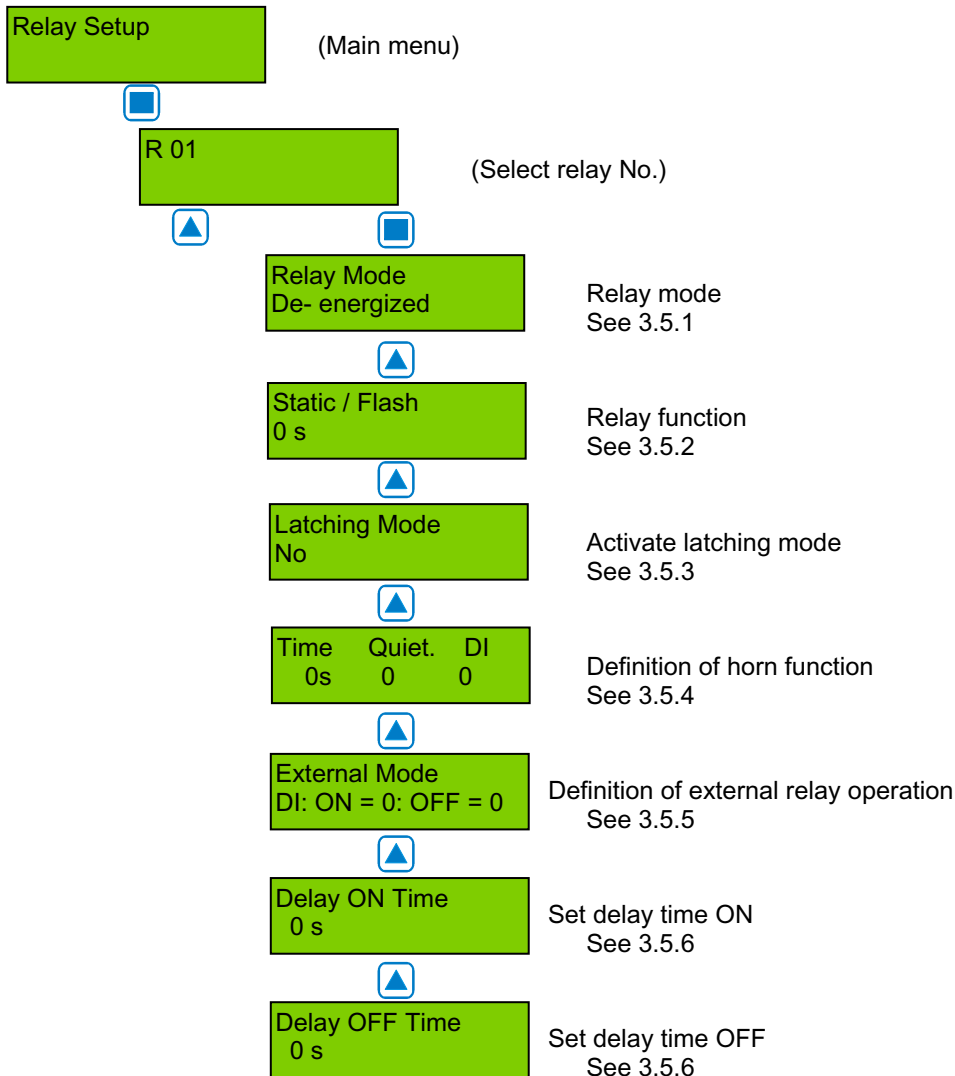

PolyGard® is a registered trademark of MSR-Electronic GmbH | SPC3-11XX US

3.5.1 Relay Mode

Definition of relay mode:

Symbol	Description	Setting Status	Function
R 01	Relay No.		Selection of relay
De-energized	Relay Mode	energized	De-energized = Alarm ON = Relay ON Energized = Alarm ON = Relay OFF

3.5.2 Relay Function Static / Flash

Definition of relay function

Symbol	Description	Setting Status	Function
R 01	Relay No.		Selection of relay
0	Function	0	0 = Relay function static > 0 = Relay function flashing (= Time period in sec.) Impulse / Break = 1:1

3.5.3 Latching Mode

Definition of latching function

Symbol	Description	Setting Status	Function
R 01	Relay No.		Selection of relay
No	Latching Mode	No	No = Latching mode non active Yes = Latching mode active

Acknowledging a latching relay in the menu “Relay Status” is only possible if the gas concentration is again lower than the alarm Stage/Set Point including hysteresis. In this case the status latching occurs in the display.

Example: Alarm relay R2 with latching mode

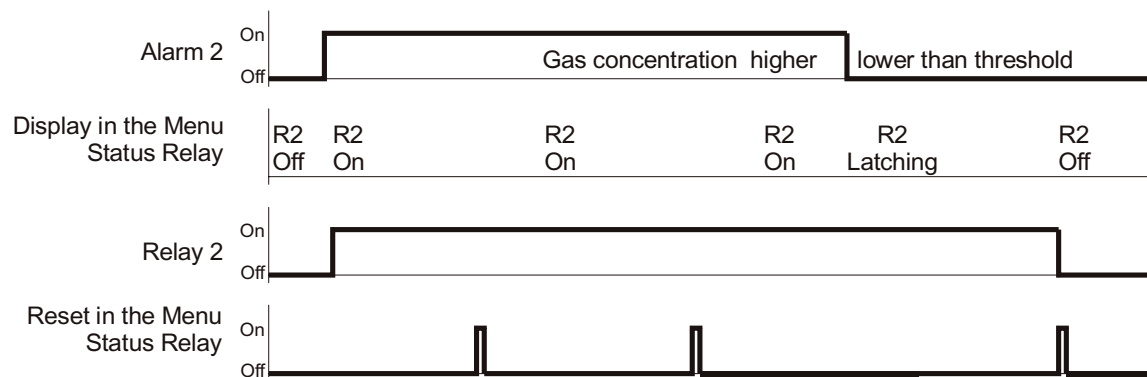

3.5.4 Horn Function

The internal horn is connected to alarm relay R3 (open collector).

This alarm output is defined as horn relay by this setup with the following possibilities to reset.

- By pressing any of the 4 push-buttons (only possible in the starting menu).
- Automatic reset at the end of the fixed time.
- By an external push-button (assignment of the appropriate digital input).

The horn function is only activated if at least one of the two setups (time or digital input) is set.

Special function Response

After acknowledging the output (by push-button or externally) time starts. When this time has run out and the alarm is still acting, the relay is set again.

Symbol	Description	Setting Status	Function
R 03	Relay No.		Selection of relay
Quit	Mode	0	0 = Reset of the relay after time having run out, or by push-button 1 = Reset of the relay by push-button, after time having run out and when alarm is still acting, relay is set again. (Response function).
Time		120	Time for automatic reset function or response function 0 = no reset function
DI		0	Assignment, which digital input resets the output.

Acknowledge the horn output

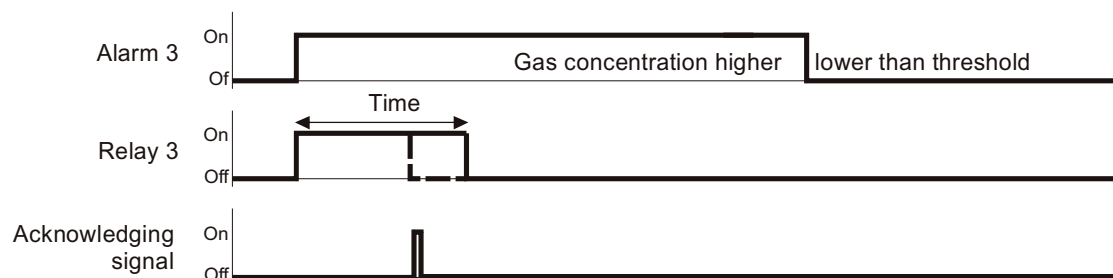

Special function "Response". (Return of the horn relay)

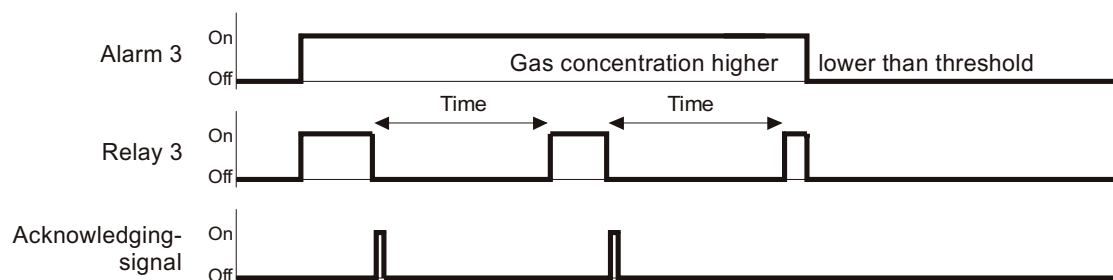

3.5.5 External Relay Operation

Assignment to a digital input (DI) for external switching of the alarm relay (ON and/or OFF). This function has priority to gas alarm and/or manual switching in the menu “Relay Status“.

Symbol	Description	Setting Status	Function
R 01	Relay No.		Relay Selection
DI-ON	External On	0	If digital input closed, relay switches ON
DI-OFF	External Off	0	If digital input closed, relay switches OFF

3.5.6 Delay Mode of the Relay.









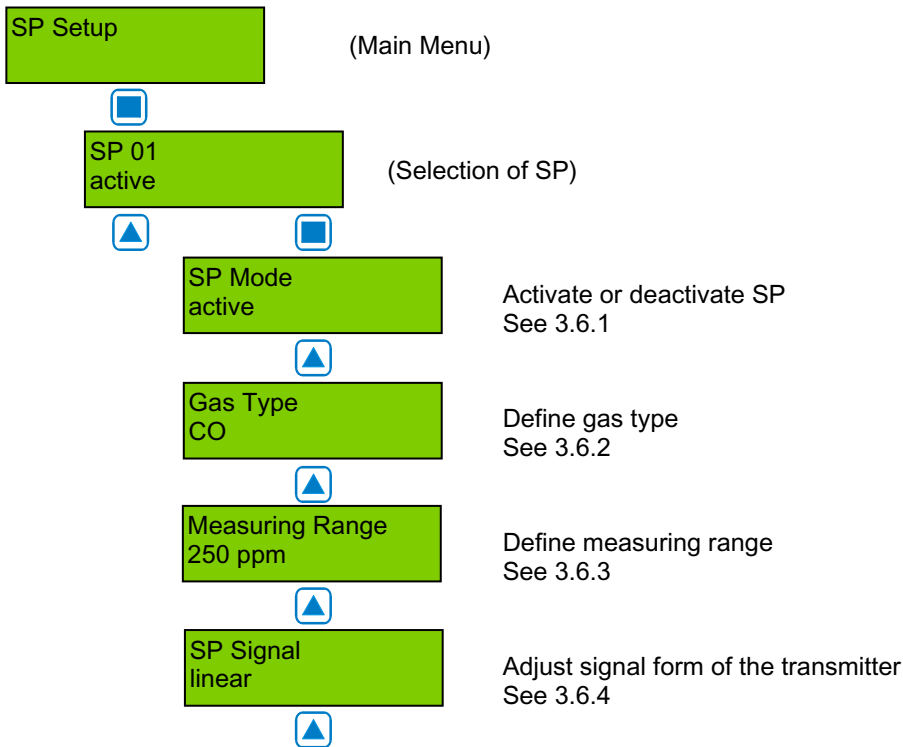

Delay time ON starts when the alarm is released and/or delay time OFF starts when the alarm returns to normal condition.

Symbol	Description	Setting Status	Function
R 01	Relay No.		Relay Selection
0 s	Delay Time ON	0	Mode ON: Relay is only activated at the end of the defined time (sec.) 0 sec. = No delay
0 s	Delay Time OFF	0	Mode OFF: Relay is only deactivated at the end of the defined time (sec.) 0 sec. = No delay

3.6 Menu SP Setups

Display and change of setups, assignment of alarms to alarm relays and activation of Sensor Points (SP).



Stage/Set Point 1 50 ppm	Define Stage/Set Point 1 See 3.6.5
	
Stage/Set Point 2 100 ppm	Define Stage/Set Point 2 See 3.6.5
	
Stage/Set Point 3 100 ppm	Define Stage/Set Point 3 See 3.6.5
	
Stage/Set Point 4 250 ppm	Define Stage/Set Point 4 See 3.6.5
	
Hysteresis 15 ppm	Hysteresis See 3.6.5
	
Delay ON Time 0 s	Set delay time ON See 3.6.6
	
Delay OFF Time 0 s	Set delay time OFF See 3.6.6
	
C/A Mode CV	Define control mode See 3.6.7
	
Alarm - 1 2 3 4 Fault - 0 0 0 0	Assign SP fault to alarm See 3.6.8
	
A1; A2; A3; A4 01; 02; 03; 04	Assign alarm to alarm relay See 3.6.9 and 3.6.10
	
Analog Output 0	Assign SP signal to analog output See 3.6.10

3.6.1 Activate – Deactivate SP

Symbol	Description	Setting Status	Function
SP 01*	Measuring point		Selection SP No.
Active	SP Status	Not active	Active = Sensor point activated at the controller Not active = Sensor point not activated at the controller

*SP01 = On Board sensor

*SP02 = External Transmitter (optional)

3.6.2 Selection Gas Type

Assign gas type to attached gas transmitters.

Symbol	Description	Setting Status	Gas type		Unit	Measuring range ¹
SP 01	Measuring point					
			CO	Carbon monoxide	ppm	0 – 250
			Ex	Combustible gas	%LEL	0 – 100
			NO	Nitrogen oxide	ppm	0 – 50
			NO ₂	Nitrogen dioxide	ppm	0 – 25
			NH ₃	Ammonia	ppm	0 – 300
			O ₂	Oxygen ²	%V/V	0 – 25
			CO ₂	Carbon dioxide	ppm	0 – 2000
			SO ₂	Sulphur dioxide	ppm	0 – 100
			H ₂ S	Hydrogen sulphide	ppm	0 – 200
			CL ₂	Chlorine	ppm	0 – 100
			ETC	Ethylene oxide	ppm	0 – 20
			VOC	Air quality	%	0 – 100
			R401	Refrigerant gas	ppm	0 – 2000
			R402	Refrigerant gas	ppm	0 – 2000
			R408	Refrigerant gas	ppm	0 – 2000
			R409	Refrigerant gas	ppm	0 – 2000
			R404	Refrigerant gas	ppm	0 – 300
			R416	Refrigerant gas	ppm	0 – 300
			R502	Refrigerant gas	ppm	0 – 300
			R410	Refrigerant gas	ppm	0 – 300
			R411	Refrigerant gas	ppm	0 – 300
			R11	Refrigerant gas	ppm	0 – 300
			R123	Refrigerant gas	ppm	0 – 300
			R134	Refrigerant gas	ppm	0 – 300
			R22	Refrigerant gas	ppm	0 – 300
			TEM	Temperature	°C	0 – 50
			RH	Humidity	% RH	0 – 100
			CO ₂	Carbon dioxide	ppm	0 – 5000
			TOX	Toxic gas	ppm	0 - XX

¹ Recommendation without obligation

² Decreasing signal at oxygen measurement!

3.6.3 Measuring Range

The measuring range can be defined arbitrarily between 0 and 10,000. The measuring ranges in the table gas type are only recommendations without obligation.

The measuring range for SP01 (inside toxic sensor) is factory set, the measuring range for SP02 must agree with the signal (4 to 20 mA / (0)2 to 10 V) of the attached gas transmitter.

(4 mA / (0)2 V = Display 0 (ppm); 20 mA / 10 V = Display of the ultimate value of the measuring range)

3.6.4 SP Signal

Gas transmitters using electro-chemical or catalytic beat gas sensors normally produce a linear 4 to 20 mA / (0)2 to 10 V signal, proportional to the gas concentration.

Semiconductor gas sensors produce a non-linear (exponential) signal. This signal leads to a non linear 4 to 20 mA / (0)2 to 10 V signal of the gas transmitter.

The Single Point Gas Controller SPC3 is prepared for both types of gas transmitters. The classification of signals is defined in this menu.

Symbol	Description	Setting Status	Function
SP 01	Measuring Point		Selection of SP No.
Linear	SP Signal	Linear	Linear = Transmitter with linear output signal Non linear = Transmitter with non-linear output signal (only AT series from MSR-E)

3.6.5 Stage/Set Point / Hysteresis

For each sensor point four alarm Stage/Set Points are available for free definition. If the gas concentration is higher than the adjusted alarm Stage/Set Point, the associated alarm is set. If the gas concentration falls below the alarm Stage/Set Point inclusive hysteresis the alarm is again reset.

Unused alarm Stage/Set Points have to be defined at measuring range end point, in order to avoid false alarms. At O₂ measurement an alarm is released by a decreasing measuring signal!

Symbol	Description	Default Status		Function
SP 01	Measuring Point			Selection SP No.
50 ppm	Stage/Set Point	50 100 100 250 15	Stage/Set Point 1 Stage/Set Point 2 Stage/Set Point 3	Gas concentration > Stage/Set Point 1 = Alarm 1 Gas concentration > Stage/Set Point 2 = Alarm 2 Gas concentration > Stage/Set Point 3 = Alarm 3 Gas concentration > Stage/Set Point 4 = Alarm 4 Gas concentration < (Stage/Set Point X – Hysteresis)

3.6.6 Delay of Alarm ON or OFF

Definition of alarm ON and/or alarm OFF delay. The function applies to all alarms of an SP.

Symbol	Description	Default Status	Function
SP 01	Sensor Point		Selection of SP No.
0 s	Delay Time ON	0	Gas concentration > Stage/Set Point: Alarm is only activated at the end of the fixed time (sec.). 0 sec. = No Delay
0 s	Delay Time OFF	0	Gas concentration < Stage/Set Point: Alarm is only deactivated at the end of the fixed time (sec.). 0 sec. = No Delay

3.6.7 Control Mode

Definition of the alarm evaluation by means of current (CV) or average value (AV).

Symbol	Description	Default Status	Function
SP 01	Sensor Point		Selection of SP No.
CV	Evaluation	CV	CV = Control by the current gas value AV = Control by the average gas value

Current- average value function see: 3.7.4

3.6.8 SP Fault Assigned to Alarm

Definition, which alarms are activated in case of a fault at the measuring point.

Symbol	Description	Default Status	Function
SP 01	Measuring Point		Selection of SP No.
Alarm - 1 2 3 4 Fault - 0 0 0 0	Failure SP	0 0 0 0	0 = Alarm not ON at SP failure 1 = Alarm ON at SP failure

3.6.9 Alarm Assigned to Alarm Relay

Each of the 4 alarms can be assigned to any alarm relay. Unused alarms are not assigned to any alarm relay.

Symbol	Description	Default Status	Function
SP 01	Measuring Point		Selection of SP No.
1	A1 A2 A3 A4	01 02 03 04	01 = Alarm 1 activates alarm relay R 01 02 = Alarm 2 activates alarm relay R 02 03 = Alarm 3 activates alarm relay R 03 00 = Alarm 4 doesn't activate any alarm relay

3.6.10 SP Signal Assigned to Analog Output

The sensor point signal can be assigned to the analog output. At this the signal defined in the control mode (current or average value) is transmitted.

Analog output see also: 3.7.7

Symbol	Description	Default Status	Function
SP 01	Measuring Point		Selection of SP No.
0	A	0	0 = SP Signal not assigned to analog output 1 = SP Signal assigned to analog output 1

3.7 Menu System Setups

Displays and changes the system setups of the Gas Controller module.



3.7.1 Service Mode

When the service mode is active (ON) the alarms are not transmitted to the alarm relays (in case of calibration or service work). The service mode is reset automatically after 60 minutes or manually in the menu “Service Mode”.

Symbol	Description	Default Status	Function
Off	Service Mode	Off	Off = Alarms activate the associated alarm relays On = Alarms are not transmitted to the alarm relays

3.7.2 Software Version

Symbol	Description	Default Status	Function
GC03-XX	Software Version		XX = Software Version

3.7.3 Maintenance Concept

Integrated in the SPC-03 system there is a control of the maintenance intervals required by law or by the customer. At commissioning or after maintenance the number of days until the next due maintenance is entered = Reset of the maintenance message (service phone no.). When the days counter reaches zero, the failure signal is activated the following morning at 9 o'clock, and the phone no. of the service technician occurs in the display. The remaining days until the next maintenance can be read from the menu “Maintenance in”.

The service phone no. can be entered individually in the next menu.

Symbol	Description	Default	Function
XXX	Maintenance After		Remaining days until the next maintenance
XXX	Maintenance Period	912	Reset of the maintenance message by entering the number of days until the next maintenance
0853....	Phone No.		Input of the individual service phone no.

3.7.4 Average Function

For each active sensor point the Single Point Gas Controller calculates the arithmetic average value out of 10 measurements got within the time unit defined in the menu “AV Time”. This average value is indicated in the menu “Sensor Reading” next to the current value. At each sensor point the control mode (current or average value) is defined for the alarm evaluation.

The alarm evaluation of the control mode average value is overlaid by the current value, when the current value exceeds the alarm Stage/Set Point defined in the menu “AV Overlay”. The overlay is delayed by the time factor defined in this menu. With time factor 0 sec. the overlay is not active.

Symbol	Description	Default Status	Function
120 s 120 ppm	AV Overlay	120 s 120 ppm	sec. = Delay time of average value overlay. 0 = No overlay function ppm = Alarm Stage/Set Point of average overlay
1800 s	AV Time	1800 s	sec. = Time for the calculation of the average value

3.7.5 System Time, System Date

Time and date have no memory back up; therefore after each power supply OFF-ON time and date restart.

Input and correction of time and date. Selection of the time and date format.

Symbol	Description	Default Status	Function
US	Time format	US	EU = Display of time and date in EU format US = Display of time and date in US format
hh.mm.ss	Time		hh.mm.ss = Input of the correct time (EU format) hh.mm.ss am = Input of the correct time (US format)
MM.DD.YY	Date		MM.DD.YY = Input of the correct date (EU format) MM.DD.YY = Input of the correct date (US format)

3.7.6 Customer Password (Code 1)

Change the system password for level 1

Symbol	Description	Default Status	Function
1234	Customer Password	1234	1234 = Define the customer's password with 4 characters

3.7.7 Analog Output

The Single Point Gas Controller has one analog output (AO01) with (0)4 to 20 mA / (0)2 to 10 V signal. The signal of SP01 or/and SP02 can be assigned to the analog output. The assignment is effected in the menu "SP Setups" for each SP. The sensor point sends the signal, which is defined in the menu "C/A Mode".

The output signal (mA / V) and starting point (0 / 20%) is selected at the I/O Board by means of jumper. See fig. 5.

Out of the signals of all assigned measuring points the Single Point Gas Controller determines the minimum, the maximum or the average value and transmits it to the analog output. The definition, which value is transmitted, is effected in the menu "Analog Output 1".

The analog output can be calibrated at 4 and at 20 mA, only in mA mode. Therefore an ampere meter (measuring range 25 mA) can be attached to the AO and the respective factor has to be changed until the analog output corresponds to 4 and/or 20 mA. During calibration evaluation of the sensor point signals is not possible. This calibration is effected by the factory. The factors shall not be changed.

Symbol	Description	Default Status	Function
Max.	Select Output Mode	Max.	Min. = Displays the minimum value of all assigned SP Max. = Displays the maximum value of all assigned SP Average = Displays the average value of all assigned SP
4.0 20.0	Calibration	4.0 20.0	4. = Calibration factor at 4 mA 20.0 = Calibration factor at 20 mA

3.7.8 Define the Failure Relay

Definition of the failure relay. See also fault management (3.1)

Symbol	Description	Default Status	Function
0X	Fault Relay	R0X	R0X = Define the fault relay

3.7.9 Power On Time

Gas sensors need a running-in period, until the chemical process of the sensor reaches stable conditions. During this running-in period the current signal can lead to an unwanted releasing of a pseudo alarm. Therefore the power on time is started at the SPC3 after having switched on the power supply. While this time is running out, the Gas Controller does not activate any alarms. The power on status occurs in the starting menu.

Symbol	Description	Default Status	Function
30 s	Power On Time	30 s	XX = Define the power on time (sec.)

4 Mounting / Electrical Connection

The Gas Controller is fixed to the wall through the marked mounting holes at the back side of the housing. These mounting holes are accessible after opening the housing. For the mounting you have to plug off the PCB. See fig. 01.

The mounting holes at the plastic housing are covered with the enclosed caps after the end of the assembly.

We recommend considering the following when choosing the mounting position:

- Installation height approx. 1.6 m.
- Cables are introduced from below.
- Keep at least 150 mm of distance on the right side in order to open the stainless steel housing.
- Customer’s instructions.

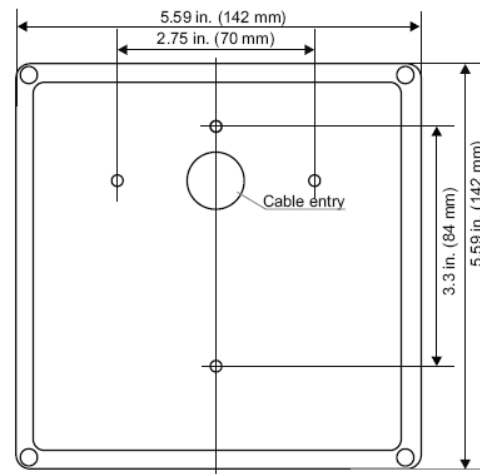
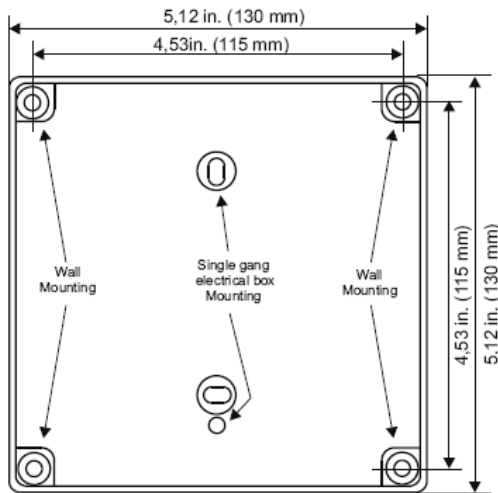

Fig. 01 Standard plastic housing

Stainless steel housing

4.1 Electrical Connection

The technical requirements and regulations for wiring, electrical security, as well as project specific and environmental conditions etc. must be observed when mounting.

The electrical installation may only be completed by a qualified electrician in full compliance with pertinent regulations.

¹ The recommendation does not consider local conditions such as fire protection etc.

For the exact position of the terminals see the following connection diagram.

4.2 Connection Diagram

Connection diagram with Option external Transmitter 4 to 20 mA*
Fig. 2

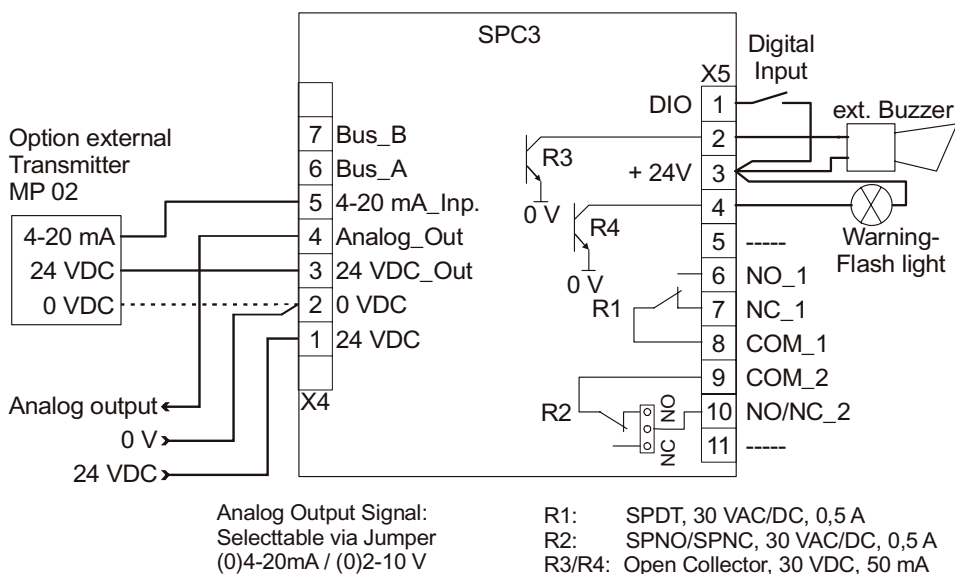

Connection diagram with Option external Transmitter (0) 2 to 10 V*
Fig. 3

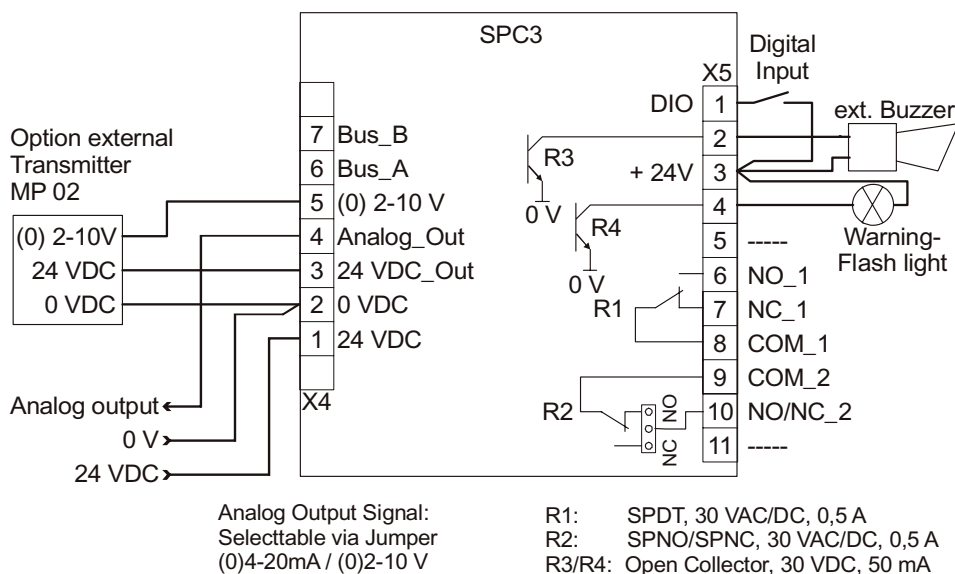

* The analog input function is determined by the hardware. Each PCB has got a label with the specific type.

4.3 Connector Block / Overview SPC3 Module

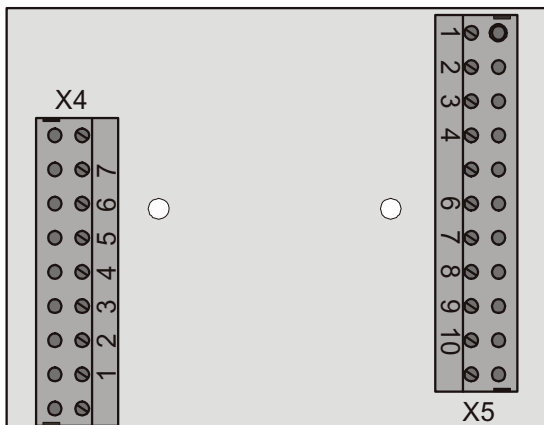

Fig. 4

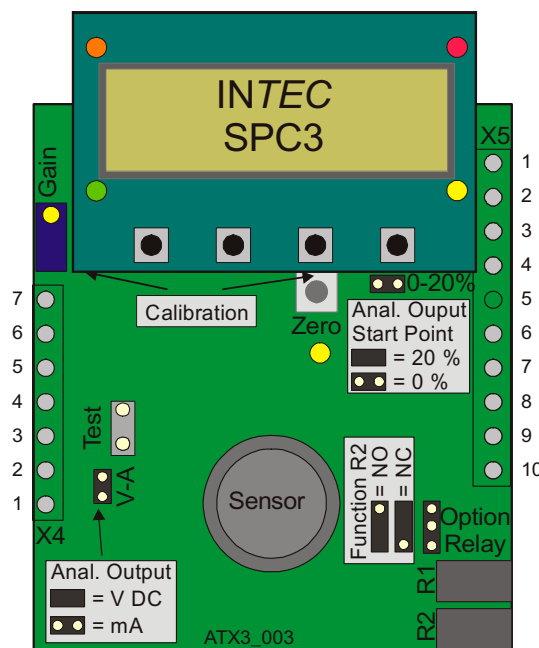

Fig. 5

5 Commissioning

5.1 Commissioning

Prior to commissioning, the wiring of the SPC3 including all field devices must be completely terminated!

Check the optional external transmitter input signal, it has to be the same as indicated on the label of the PCB. See Fig. 5

Select the contact for relay 2 with jumper NC/NO. See fig. 2/3 and 5.

Select the analog output signal with jumper V-A and 0-20%. See Fig. 5

After switching the power supply “ON” and at the end of the Power ON Time, the SPC3 is ready for use.

The SPC3 is delivered with standard setups and set points. The registration of the optional external gas transmitter and the assignment of the alarm relays to the individual alarms must always be performed during commissioning. Additionally all other setups have to be checked and adapted to the local conditions.

The standard setups can be taken from the following configuration and setup card. We recommend registering the individual setups and set points into the list.

We recommend checking the setups and set points according to the following check list.

5.2 Checklist Commissioning

System Setup

Setup	Finished
Time and date	
Setup of average function	
Password level 1 (customer's password)	
Function analog output	
Define fault relay	
Power ON time	
Service phone no.	
Maintenance date	

Relay Setup

Setup	Finished				
	Relay R	1	2	3	4
Relay mode					
Function static / flash					
Latching mode					
Horn function					
External relay operation					
Delay ON time					
Delay OFF time					

SP Setup

Setup	Finished		
	SP No. ¹	1	2
SP mode			
Gas type			
Measuring range			
SP signal			
Stage/Set Point 1			
Stage/Set Point 2			
Stage/Set Point 3			
Stage/Set Point 4			
Hysteresis			
Delay ON time			
Delay OFF time			
C/A mode			
Assigned failure <> alarm			
Assigned alarm <> alarm relay			
Assig. SP sig. <> analog output			

¹ SP 01 = On Board Sensor, SP 02 = external Transmitter

6 Configuration and Setup Card

Commission:		Project No.	
Customer:			
Commissioning - Company			
Commissioning - Date		Service Technician	

6.1 Configuration Card of System Setups

Service	Software Version	Maintenance Date	Service Phone	AV Overlay			Time System	Costumer Pass	Power ON Time	Fault Relay
				ppm	Time	AV Time				
Default	GC 03	06.06.08	0853190040	120	120	1800	EU	1234	30 s	0

Analog Output 1		
	Calibration	
Mode	= 4	= 20
Max.	4.0	20.0

6.2 Configuration Card of Alarm Relays

Relay No.	Mode	Static Flash	Latching Mode	Horn Function			External		Delay Time	
				Time	Quiet	DI	ON	OFF	ON	OFF
Default	Energized	0 s	No	0	0	0	DI	DI	DI	DI
R01										
R02										
R03										
R04										

6.3 Configuration Card of Measuring Setups

SP No.	SP Status	Gas Type	Measuring Range	SP Signal	Stage/Set Points				Hyst
					A1	A2	A3	A4	
De fault	Not active	CO	250	Linear	50	100	100	250	15
01									
02									

Delay Time (sec.)		CV/ AV	Assigned SP Fault < > Alarm				Assigned Alarm < > Alarm Relay				AO
ON	OFF		A1	A2	A3	A4	A1	A2	A3	A4	
0	0	CV	0	0	0	0	R1	R2	R3	R4	0

7 Specifications SPC3

Electrical	
Power supply	18-28 VDC/AC, reverse polarity protected
Power consumption (without options)	100 mA, max. 2.5 VA
Power Consumption with (1) remote sensor connected	200mA, 5 VA
Analog output signal Selectable: Current / Voltage : Starting point 0 or 20%	(0)4-20 mA, load $\leq 500 \Omega$ (0)2-10 V, load $\geq 50 k\Omega$ Proportional, overload and short-circuit-proof
Alarm relay (R1)	30 VAC/DC, 0.5 A, potential-free, SPDT
Alarm relay (R2)	30 VAC/DC, 0.5 A, potential-free, SPNO/SPNC
Binary output (R3; R4) R3= 30VDC, .05 A (Internal Buzzer) R4= 30VDC switch output	30 VDC, 0.05 A open collector output
Visualization	
Display	Two lines, each 16 characters
Status LED (4)	Normal operation- Fault- Alarm 1- Alarm 2
Operation	4 push- buttons, menu-driven
Operation Environment	
Humidity	15-90% RH non-condensing
Working temperature	- 10°C to + 50°C (14°F to 122°F)
Storage temperature	-5°C to 30°C (23°F to 86°F)
Pressure range	Atmospheric $\pm 10 \%$
Physical	
Enclosure (panel) Material	
-Conformity	Polycarbonate, UL 94-HB, fire-retardant
-Color	UL 50 standards
-Dimensions (W x H x D)	Light Grey
-Weight	130 x 130 x 75 mm (5.12 x 5.12 x 2.95 in.)
-Protection class	Approx. 0.6 lbs (0.3 kg)
-Installation	NEMA 12 (IP55)
-Cable entry	Wall (surface) mounted
-Wire connection Terminal blocks.	3 holes for 1/2 in. conduit for wall (surface) mounted and 1 hole on back side of base plate for single gang electrical box mounting
-Wire size	Min 24 AWG (0.25 mm ²) Max. 14 AWG(2.5 mm ²)
-Wire distance	Max loop resistance 450 Ohm (= Wire distance plus controller input resistance)
Enclosure Metal Material	
-Color	galvanized steel w/zinc coating, corrosion resistant
-Dimensions (W x H x D)	RAL 7032 (light grey)
-Weight	142 x 142 x 63 mm (5.59. 5.59 x 2.48 in.)
-Protection	Approx. 0.6 lbs (0.3 kg)
-Installation	NEMA 1, general purpose
-Cable entry	Wall mounting
-Wire connection	3 holes for 1/2 in. conduit for wall (surface) mounted and 1 hole on back side of base plate for single gang electrical box mounting
	Screw type terminals min. 0.25 to 2.5 mm ² (14 to 30 AWG)

Approvals / Listings	
-unit	CE Certification to UL 2075 & UL 2017 - "Pending" VDI 2053, C-No. 418791 EMV-Compliance 89/336/EWG EMV-Compliance 2004/108/EWG Low voltage directive 73/23/EWG
-sensor	UL Recognized
-relays (R1-R2)	UL Recognized, E41515 CSA, C22.2 No. 0, No. 14 (File No. LR31928)
-enclosure	UL Listed, E208470 CSA Certified, E208470

Options

Analog input (external transmitter)	
Analog input (1)	4-20 mA, input resistance 200 Ω, (0)2-10V, input resistance 25 kΩ, overload- and short-circuit-proof
Power supply for external analog transmitter	24 VDC/VAC (depending on voltage input for unit) max. 50 mA
Buzzer	
Acoustic pressure	83 dB (A) (distance 300 mm) (1. ft)
Frequency	3.5 kHz
Serial Interface	
Transceiver	RS 485 / 19200 Baud
Heating	
Temperature controlled	3 ± 2°C (38°F ± 36°F)
Ambient temperature	-20°C (-4°F)
Power consumption	0.5 A; 12 VA

8 Gas Sensor

8.1 Description

The sensor is a micro-fuel cell, which is completely sealed. The measurement is a gas-in-liquid chemical reaction rather than a surface area measurement. With no surface area to coat, this sensor retains its sensitivity to carbon monoxide even after prolonged exposure to clean air.

The cell consists of a diffusion barrier, O-ring seal, electrolyte reservoir and two electrodes. The target gas, carbon monoxide, enters the cell through a diffusion barrier. The chemical process of the measurement is one of oxidation where one molecule of the target gas is exchanged for one molecule of oxygen. The reaction drives the oxygen molecule to the counter electrode, generating a DC microampere signal between the counter electrodes. This signal is linear to the volume concentration of the sensed gas rather than the partial pressure.

The transmitter electronics will provide the necessary bias voltage when configured for one of these sensor types. Most sensors produce a small amount of baseline current in clean air. This is adjusted out with the zero push button on the transmitter.

This oxidation at the electrodes causes wear of the sensor. Typical life for this sensor is approximately five years in normal operation. This will vary somewhat from sensor to sensor, with some working lifetimes less than five years and some more than 5 years. This wear also changes the characteristics of the sensor, requiring periodic re-calibration with the potentiometer Gain. It is recommended that the sensor accuracy be verified every twelve months and recalibrated as necessary.

8.2 Calibration

Required instruments to calibrate the transmitter:

- Test gas bottle with synthetic air or CO-free ambient air.
- Test gas bottle with CO (ppm) in the range of 30 – 80 % of the measuring range.
- Gas pressure regulator with flow meter to control the gas flow to 150 ml/min.
- Calibration adapter with tube. Type: CONKIT-E/CH-LC See fig. 06
- Small screwdriver.

Note: Please observe proper handling procedures for test gas bottles!

- 1) Type gas depends on model #.
- 2) Flow rate depends on model # and diameter of element.
- 3) Calibration adaptor depends on model # and diameter of element.

8.3 Zero-Point Calibration

Consider the running-in period of the sensor (at least 1 hour).

- Open window SP 01 in menu “Measuring Value”.
- Connect calibration adapter carefully to the sensor element.
- Apply synthetic air (150 ml/min; 1 Bar (14.5 psi) \pm 10%), or CO-free ambient air.
- Wait 1 minute until the measuring signal at SP 01 is stable, push button “Zero” for 5 seconds.
After successful calibration the measuring signal is corrected automatically.
If the zero-point is out of the admissible range ($>$ 10 % of measuring range) before calibration, there is no correction of the measuring signal. The sensor has to be replaced.
- Remove calibration adapter carefully by turning lightly. Check the sensor for correct mounting!

8.4 Gain Calibration

Notes:

CO calibration gas is toxic, never inhale the gas!

Symptoms: Dizziness, headache and nausea.

Procedure if exposed: Take the victim into fresh air at once, call a doctor.

- Open window SP 01 in menu “Measuring Value”.
- Connect calibration adapter carefully to the sensor element.
- Apply calibration test gas CO (300 ml/min; 1 Bar (14.5 psi) \pm 10%).
- Wait two minutes until the measuring value is stable, adjust the value with potentiometer “Gain” until the value corresponds to the Calibration gas concentration.
- Remove calibration adapter with a careful light turn. Check the sensor for correct mounting!
By limiting the gain factor, calibration will not be possible any more when the sensitivity of the sensor reaches a residual sensitivity of 30%. Then the sensor has to be replaced.

8.5 Exchange of Sensor Element

Consider static electricity! See point 3.

Sensor should always be installed without power applied:

- Unplug old sensor element from the PCB.
- Take the new sensor out of the original packing.
- Plug in the sensor element into the PCB at X3/X7.
- Calibrate according to section 8.

8.6 Specification Gas Sensor

Sensor performances		
Gas type	Carbon monoxide (CO)	
Sensor element	Electrochemical, diffusion	
Measuring range (standard, other ranges according to the data sheet)	0 - 250 ppm (ex works) adjustable between 0-150 and 0-300 ppm	
Pressure range	Atmosphere \pm 15 %	
Storage time	Max. 6 months	
Mounting height	1.5 to 1.8 m (5 to 6 ft.)	
Accuracy	\pm 3 ppm	
Stability & resolution	\pm 3 ppm of reading	
Repeatability	\pm 3 % of reading	
Long-term output drift	< 5% signal loss/year	
Response time	t_{90} < 50 sec.	
Life expectancy	> 5 years/normal operating environment	
Humidity range – short-term	0 – 95 % RH non condensing	
Temperature range - continuous	-10°C to + 50°C (14°F to 122°F)	
Temperature range – short-term	-20°C to + 50°C (-4°F to 122°F)	
Cross sensitivity*	Concentration (ppm)	Reaction (ppm CO)
Acetone, C ₃ H ₆ O	1000	0
Acetylene, C ₂ H ₂	40	80
Ammonia, NH ₃	100	0
Chlorine, Cl ₂	2	0
Ethanol, C ₂ H ₅ OH	2000	5
Iso Propanol, C ₃ H ₈ O	200	0
Carbon dioxide, CO ₂	5000	0
Nitrogen dioxide, NO ₂	50	-1.0
Nitric oxide, NO	50	8
Sulphur dioxide, SO ₂	50	< 0.5
Hydrogen Sulphide, H ₂ S	25	0
Hydrogen, H ₂	100	20

Calibration adapter

Fig. 6

Type: CONKIT-E/CH-LC



PolyGard® is a registered trademark of MSR-Electronic GmbH | SPC3-11XX US

9 Notes and General Information

It is important to read this user manual carefully in order to understand the information and instructions. The PolyGard® SPC3 gas monitoring, control and alarm system may only be used for applications in accordance to the intended use. The appropriate operating and maintenance instructions and recommendations must be followed.

9.1 Intended Product Application

The PolyGard® SPC3 is designed and manufactured for controlling, for saving energy and keeping OSHA air quality in commercial buildings and manufacturing plants (i.e. detection and automatic exhaust fan control for automotive maintenance facilities, enclosed parking garages, engine repair shops, warehouses with forklifts, fire stations, tunnels, etc.).

9.2 Installers` Responsibilities

It is the installer's responsibility to ensure that all PolyGard® SPC3 are installed in compliance with all national and local regulations and OSHA requirements. All installations shall be executed only by technicians familiar with proper installation techniques and with codes, standards and proper safety procedures for control installations and the latest edition of the National Electrical Code (ANSI/NFPA70). It is also essential to follow strictly all instructions as provided in the user manual.

9.3 Maintenance

We recommended checking the PolyGard® SPC3 system regularly. Due to regular maintenance differences in efficiency can easily be corrected. Limited Warranty Re-calibration and part replacement may be implemented in the field by a qualified technician and with the appropriate tools. Alternatively, the easily removable plug-in transmitter card with the sensor may be returned for service to INTEC Controls.

9.4 Limited Warranty

MSR-Electronic-GmbH and INTEC Controls warrants the PolyGard® SPC3 for a period of two years, 12 months normal exposure for the sensor, from the date of shipment against defects in material or workmanship. Should any evidence of defects in material or workmanship occur during the warranty period, INTEC Controls will repair or replace the product at their own discretion, without charge.

This warranty does not apply to units that have been altered, had attempted repair, or been subject to abuse, accidental or otherwise. The warranty also does not apply to units in which the sensor element has been overexposed or gas poisoned. The above warranty is in lieu of all other express warranties, obligations or liabilities.

This warranty applies only to the PolyGard® SPC3. MSR-Electronic-GmbH and/or INTEC Controls shall not be liable for any incidental or consequential damages arising out of or related to the use of the PolyGard® SPC3.

If the PolyGard® SPC3 needs to be returned to INTEC Controls for service, an RMA number must be obtained prior to sending.